

# **OPTIMAL CONFIGURATION SELECTION FOR RECONFIGURABLE MANUFACTURING SYSTEMS**

by

**Ayman Mohamed Ashraf Mohamed Youssef**

A Dissertation

Submitted to the Faculty of Graduate Studies and Research through  
Industrial and Manufacturing Systems Engineering  
in Partial Fulfillment of the Requirements for  
the Degree of Doctor of Philosophy at the  
University of Windsor

Windsor, Ontario, Canada

2006

© Ayman M. A. Youssef



Library and  
Archives Canada

Bibliothèque et  
Archives Canada

Published Heritage  
Branch

Direction du  
Patrimoine de l'édition

395 Wellington Street  
Ottawa ON K1A 0N4  
Canada

395, rue Wellington  
Ottawa ON K1A 0N4  
Canada

*Your file* *Votre référence*  
*ISBN: 978-0-494-35979-2*  
*Our file* *Notre référence*  
*ISBN: 978-0-494-35979-2*

#### NOTICE:

The author has granted a non-exclusive license allowing Library and Archives Canada to reproduce, publish, archive, preserve, conserve, communicate to the public by telecommunication or on the Internet, loan, distribute and sell theses worldwide, for commercial or non-commercial purposes, in microform, paper, electronic and/or any other formats.

The author retains copyright ownership and moral rights in this thesis. Neither the thesis nor substantial extracts from it may be printed or otherwise reproduced without the author's permission.

#### AVIS:

L'auteur a accordé une licence non exclusive permettant à la Bibliothèque et Archives Canada de reproduire, publier, archiver, sauvegarder, conserver, transmettre au public par télécommunication ou par l'Internet, prêter, distribuer et vendre des thèses partout dans le monde, à des fins commerciales ou autres, sur support microforme, papier, électronique et/ou autres formats.

L'auteur conserve la propriété du droit d'auteur et des droits moraux qui protègent cette thèse. Ni la thèse ni des extraits substantiels de celle-ci ne doivent être imprimés ou autrement reproduits sans son autorisation.

---

In compliance with the Canadian Privacy Act some supporting forms may have been removed from this thesis.

Conformément à la loi canadienne sur la protection de la vie privée, quelques formulaires secondaires ont été enlevés de cette thèse.

While these forms may be included in the document page count, their removal does not represent any loss of content from the thesis.

Bien que ces formulaires aient inclus dans la pagination, il n'y aura aucun contenu manquant.

  
**Canada**

## ABSTRACT

The selection of manufacturing system configurations, that include arrangement of machines, equipment selection and assignment of operations, has a significant impact on their performance especially when considering the new paradigm, namely Reconfigurable Manufacturing Systems (RMS). The objective of RMS is to provide the capacity and functionality needed when needed with the least amount of reconfiguration effort. The use of stochastic analysis and rules-guided planning for the anticipated reconfiguration process in the optimal selection of multiple-aspect RMS configurations, capable of producing multiple-part types simultaneously, achieves the above RMS objective.

In order to achieve the goal of this work, a new “RMS Configuration Selection Approach” was developed. It consists of two stages; the first deals with the selection of near-optimal alternative configurations for each possible demand scenario over the considered configuration periods. It uses a novel constraint satisfaction procedure and powerful meta-heuristics, Genetic Algorithms (GAs) and Tabu Search (TS), for optimizing capital cost and system availability. The second stage utilizes GAs and TS to determine the alternatives, from those produced in the first stage, that would optimize the degree of transition smoothness over the planning horizon. A reconfiguration smoothness (RS) metric is introduced to provide a relative measure of the effort, time and cost required to reconfigure the system. It performs a stochastic analysis of the level of reconfiguration smoothness across all the configuration periods in the planning horizon according to the anticipated demand scenarios. Reconfiguration planning rules are introduced to guide the development of execution plans for system-level reconfiguration, and accordingly reduce the physical effort of reconfiguring the system. The developed approach was demonstrated and validated using a case study. Analysis of different cases of availability considerations was performed. Results using GAs versus TS were consistent for most of the optimization models developed.

This research work enhances the existing knowledge with regards to performance evaluation and configuration selection of manufacturing systems. This work also supports

management in selecting RMS configurations at the beginning of each configuration period.



## DEDICATION

*To my late father who taught me to be a responsible persevering person full of trust and self confidence without which I would never have accomplished this achievement.*

## ACKNOWLEDGEMENTS

I would like to express my sincere appreciation to my advisor, Dr. Hoda ElMaraghy, for her contributions, guidance and continuous support throughout my Ph.D. program which enabled me to complete my research work and present it in an acceptable form. Dealing with her was a continuous learning process for me through which I gained a lot of experience in the research field. My committee members, Dr. Waguih ElMaraghy, Dr. Walid Abdul-Kader and Dr. Ahmed Tawfik, are to be highly recognized as well for their time and valuable suggestions that added to this work.

Many thanks to those who helped me create a healthy research environment on campus including my colleagues in the Intelligent Manufacturing Systems (IMS) Centre, Ms. Jacque Mummery, the secretary of the Industrial and Manufacturing Systems Engineering Department, and Ms. Zaina Batal, the research administrative assistant of the IMS Centre.

My utmost gratitude to my dear mother for her endless sacrifice and care throughout my life. A very sincere appreciation to my beloved wife who has provided me with every kind of support that I needed while sharing with me this life time experience with unmatched patience in addition to my lovely son who has added an inspirational dimension to my life throughout his three years of age. I would like also to thank my brother and his family for their love and support.

I would like to extend my gratitude to all my friends who have always been a source of encouragement and support in my academic and social life.

Special thanks to those who helped me create a mission and persevere on the path of this mission. I especially recognize Dr. Ashraf Nassef who introduced me to the field of academic research and was a source of encouragement for me to continue in this career and relate it to my mission.

# TABLE OF CONTENTS

<b>ABSTRACT</b> .....	<b>III</b>
<b>DEDICATION</b> .....	<b>V</b>
<b>ACKNOWLEDGEMENTS</b> .....	<b>VI</b>
<b>LIST OF TABLES</b> .....	<b>XIII</b>
<b>LIST OF FIGURES</b> .....	<b>XIV</b>
<b>LIST OF ABBREVIATIONS</b> .....	<b>XVII</b>
<b>NOMENCLATURE</b> .....	<b>XIX</b>
<b>1. INTRODUCTION</b> .....	<b>1</b>
1.1 OVERVIEW OF MANUFACTURING SYSTEMS .....	1
1.2 RECONFIGURABLE MANUFACTURING SYSTEMS (RMS).....	2
1.3 MOTIVATION.....	3
1.4 OBJECTIVES AND APPROACH .....	5
1.5 OVERVIEW OF THE DISSERTATION .....	9
<b>2. LITERATURE REVIEW</b> .....	<b>11</b>
2.1 INTRODUCTION .....	11
2.2 MANUFACTURING SYSTEM DESIGN DECOMPOSITION (MSDD) .....	13
2.3 STOCHASTIC HIERARCHICAL APPROACH .....	14
2.4 EVOLUTION-BASED PLANNING SYSTEM .....	15
2.5 A FRAMEWORK FOR A STOCHASTIC MODEL OF A RMS .....	15
2.6 SYSTEM PERFORMANCE ANALYSIS APPROACH.....	16
2.7 MULTI-PART OPTIMAL LINE DESIGN .....	18
2.8 ALTERNATIVE CONFIGURATION PATH GENERATION .....	19
2.9 DESIGN METHODOLOGY FOR SCALABLE MACHINING SYSTEMS .....	20
2.10 SUMMARY OF THE LITERATURE REVIEW.....	21

<b>3. RMS CONFIGURATION SELECTION APPROACH.....</b>	<b>24</b>
3.1 BASIC ASSUMPTIONS .....	24
3.1.1 Configuration Structure.....	24
3.1.2 Configuration Periods (CPs).....	26
3.2 INPUT DESCRIPTION .....	27
3.2.1 Demand Scenarios (DSs).....	27
3.2.2 Parts Processing Information (OPs, OCs, OSs and PGs).....	28
3.2.2.1 Operations (OPs).....	29
3.2.2.2 Operation Clusters (OCs).....	29
3.2.2.3 Operation Clusters Setups (OSs).....	30
3.2.3 Machines/Stations (Ms) Information.....	30
3.2.4 Machine Configurations (MCs) Information.....	31
3.2.5 Feasibility and Operation Time for each M-MC-OS Combination.....	32
3.2.6 Space Limitations.....	33
3.2.7 Investment Limitation .....	33
3.2.8 The Configuration (C0) of CP0 .....	33
3.3 OUTPUT DESCRIPTION.....	34
3.4 RMS CONFIGURATION SELECTION PROCEDURE .....	35
3.4.1 The First Stage.....	35
3.4.2 The Second Stage.....	37
<b>4. MODELING AND OPTIMIZATION OF MULTIPLE-ASPECT RMS CONFIGURATIONS .....</b>	<b>41</b>
4.1 MATHEMATICAL MODEL .....	41
4.1.1 Assumptions .....	41
4.1.2 Decision Variables.....	42
4.1.3 Objective Function and Constraints.....	42
4.1.3.1 Space Constraints .....	42
4.1.3.2 Precedence and Overlap Constraints.....	43
4.1.3.3 Functionality Constraints.....	43
4.1.3.4 Capacity Constraint .....	43
4.1.3.5 Investment Constraint.....	44

4.1.3.6 Decision Variable Domain Constraints .....	44
4.2 STRING REPRESENTATION .....	44
4.3 CONSTRAINT SATISFACTION PROCEDURE .....	45
4.3.1 Generation of Feasible OS Permutations (Sequences) for All Parts.....	46
4.3.2 Generation of Possible Stage Locations for OS Permutations.....	46
4.3.3 Generation of Feasible M-MC Alternatives for All OS Combinations.....	47
4.3.4 Mapping of Domains and Encoding of Variables .....	48
4.3.5 Decoding of Variables .....	49
4.3.5.1 Decoding the OS Sequences.....	50
4.3.5.2 Decoding the OS Distributions.....	50
4.3.5.3 Decoding the M-MC Selections .....	50
4.3.5.4 Repair Procedure .....	51
4.3.6 Penalty Function.....	51
4.4 OPTIMIZATION USING GENETIC ALGORITHMS .....	51
4.5 CASE STUDY .....	53
4.5.1 Example Part .....	53
4.5.2 Case Description.....	54
4.5.3 Results and Discussion .....	55
4.6 OPTIMIZATION USING TABU SEARCH.....	57
4.7 TABU SEARCH APPLIED TO THE CASE STUDY .....	59
4.8 SUMMARY AND CONCLUSIONS.....	60
<b>5. AVAILABILITY CONSIDERATIONS IN OPTIMIZING MULTIPLE-</b>	
<b>ASPECT RMS CONFIGURATIONS.....</b>	<b>62</b>
5.1 AVAILABILITY ASSESSMENT OF MSMS USING UGF .....	62
5.1.1 Universal Generating Function (UGF) .....	63
5.1.1.1 Brief Description .....	63
5.1.1.2 UGF Modification .....	65
5.1.2 Application to Manufacturing Systems .....	66
5.1.2.1 Multi-State Manufacturing System (MSMS) .....	66
5.1.2.2 Steady-State Availability of MSMS .....	66
5.1.2.3 Application of UGF to MSMS .....	66

5.1.2.4 Illustrative Example.....	68
5.1.3 <i>A Case Study Applying the Use of UGF in Availability Assessment of MSMS</i> .....	69
5.2 EXPECTED PRODUCTION RATE AND SYSTEM UTILIZATION EVALUATION OF MSMS USING UGF .....	71
5.3 INCORPORATING AVAILABILITY IN THE MATHEMATICAL MODEL FOR RMS CONFIGURATION SELECTION .....	72
5.4 CASE STUDY .....	74
5.4.1 <i>Optimization Results Using GAs</i> .....	75
5.4.2 <i>Optimization Results Using M-C-RTS</i> .....	77
5.4.3 <i>Discussion of Case Study Results</i> .....	78
5.5 ANALYSIS OF DIFFERENT CASES OF AVAILABILITY CONSIDERATION .....	79
5.6 SUMMARY AND CONCLUSIONS.....	86
<b>6. RECONFIGURATION SMOOTHNESS.....</b>	<b>89</b>
6.1 RECONFIGURATION SMOOTHNESS (RS) METRIC.....	89
6.1.1 <i>Market-Level Reconfiguration Smoothness (TRS)</i> .....	91
6.1.2 <i>System-Level Reconfiguration Smoothness (SRS)</i> .....	92
6.1.3 <i>Machine-Level Reconfiguration Smoothness (MRS)</i> .....	94
6.2 RECONFIGURATION PLANNING.....	96
6.2.1 <i>Reconfiguration Planning Rules</i> .....	96
6.2.2 <i>Reconfiguration planning Procedure</i> .....	97
6.2.2.1 Stage I: Determination of Exact Stage Locations for C2.....	97
6.2.2.2 Stage II: Development of Reconfiguration Execution Plans.....	98
6.3 EXAMPLE ON RECONFIGURATION PLANNING AND RS EVALUATION.....	102
6.4 CASE STUDY .....	106
6.4.1 <i>Case Description</i> .....	106
6.4.2 <i>Reconfiguration Smoothness Evaluation Results</i> .....	108
6.4.3 <i>Sensitivity Analysis</i> .....	110
6.5 SUMMARY AND CONCLUSIONS.....	112

<b>7. STOCHASTIC EVALUATION OF RECONFIGURATION SMOOTHNESS ACROSS THE PLANNING HORIZON .....</b>	<b>114</b>
7.1 STOCHASTIC RECONFIGURATION SMOOTHNESS .....	114
7.2 RECONFIGURATION SMOOTHNESS ACROSS (RSA).....	115
7.3 OPTIMIZATION OF RECONFIGURATION SMOOTHNESS ACROSS (RSA).....	117
7.4 CASE STUDY .....	118
7.4.1 <i>Optimization Results Using Integer-Coded GAs</i> .....	120
7.4.2 <i>Optimization Results Using RTS</i> .....	124
7.5 SUMMARY AND CONCLUSIONS.....	127
<b>8. CONCLUSIONS AND FUTURE WORK.....</b>	<b>129</b>
8.1 CONCLUSIONS .....	130
8.2 RESEARCH CONTRIBUTIONS.....	133
8.3 FUTURE WORK.....	136
8.4 SUMMARY .....	137
<b>REFERENCES.....</b>	<b>138</b>
<b>APPENDIX A: GENETIC ALGORITHMS.....</b>	<b>145</b>
A.1 GENERAL OVERVIEW OF GENETIC ALGORITHMS .....	145
A.2 OPERATORS USED FOR REAL-CODED GENETIC ALGORITHMS.....	146
A.2.1 <i>Selection Operators</i> .....	146
A.2.2 <i>Cross-Over Operators</i> .....	146
A.2.2.1 Arithmetic Cross-Over.....	146
A.2.2.2 Simple Cross-Over .....	147
A.2.2.3 Heuristic Cross-Over .....	147
A.2.3 <i>Mutation Operators</i> .....	147
A.2.3.1 Uniform Mutation.....	148
A.2.3.2 Boundary Mutation.....	148
A.2.3.3 Non-Uniform Mutation.....	148
A.2.3.4 Whole Non-Uniform Mutation .....	149

<b>APPENDIX B: EXAMPLE PARTS MACHINE PROCESSING INFORMATION.....</b>	<b>150</b>
<b>APPENDIX C: TABU SEARCH.....</b>	<b>154</b>
C.1 BASIC TABU SEARCH (TS) .....	154
<i>C.1.1 Strategies.....</i>	<i>154</i>
<i>C.1.2 Forbidding Strategy.....</i>	<i>155</i>
<i>C.1.3 Aspiration Criteria and Tabu Restrictions.....</i>	<i>156</i>
<i>C.1.4 Freeing Strategy.....</i>	<i>157</i>
<i>C.1.5 Use of Memory.....</i>	<i>157</i>
<i>C.1.6 Intensification and Diversification.....</i>	<i>158</i>
<i>C.1.7 Intermediate and Long-Term Learning Strategies.....</i>	<i>158</i>
<i>C.1.8 Short-Term Strategy (Overall Strategy).....</i>	<i>159</i>
C.2 REACTIVE TABU SEARCH (RTS) .....	160
C.3 CONTINUOUS REACTIVE TABU SEARCH (C-RTS) .....	161
C.4 MODIFIED CONTINUOUS REACTIVE TABU SEARCH (M-C-RTS) .....	161
<b>APPENDIX D: UNIVERSAL GENERATING FUNCTION .....</b>	<b>163</b>
<b>APPENDIX E: A SAMPLE RESULTS REPORT .....</b>	<b>168</b>
<b>VITA AUCTORIS .....</b>	<b>221</b>



## LIST OF TABLES

TABLE (1.1) COMPARISON BETWEEN DML AND FMS (KOREN <i>ET AL.</i> 1999). .....	2
TABLE (2.1) LITERATURE REVIEW SUMMARY FOR MOST RELEVANT RESEARCH WORK. ....	22
TABLE (4.1) PARAMETERS USED IN REAL-CODED GAS. ....	52
TABLE (5.1) EXAMPLE DATA. ....	68
TABLE (5.2) AVAILABILITY AND COSTS OF THE THREE CONFIGURATIONS.....	70
TABLE (5.3) PARAMETERS USED IN REAL-CODED GAS WITH THE MODIFIED MODEL. ....	74
TABLE (5.4) SUMMARY OF RESULTS OF ANALYZING DIFFERENT CASES OF AVAILABILITY CONSIDERATION. ....	81
TABLE (5.5) INFORMATION OF BEST OBTAINED NEAR-OPTIMAL CONFIGURATIONS FOR DIFFERENT CASES OF AVAILABILITY CONSIDERATION. ....	82
TABLE (7.1) PARAMETERS USED IN INTEGER-CODED GAS. ....	119
TABLE (7.2) CASE STUDY INFORMATION.....	120
TABLE (B.1) OPERATIONS DATA FOR PART ANC-101.....	150
TABLE (B.2) OPERATIONS DATA FOR PART ANC-90.....	150
TABLE (B.3) OPERATION CLUSTERS DEFINITIONS FOR PART ANC-101.....	151
TABLE (B.4) OPERATION CLUSTERS DEFINITIONS FOR PART ANC-90.....	152
TABLE (B.5) AVAILABLE/OBTAINABLE RESOURCES DESCRIPTION AND COST.....	153
TABLE (B.6) TIME AND PRODUCTION RATE INFORMATION FOR DIFFERENT M-MC-OS COMBINATIONS. ....	153

## LIST OF FIGURES

FIGURE (1.1) FUNCTIONALITY AND CAPACITY OF MANUFACTURING SYSTEMS (YOUSSEF AND H. ELMARAGHY 2006A). .....	1
FIGURE (1.2) BOTH DML AND FMS ARE STATIC SYSTEMS, WHILE A RMS IS A DYNAMIC SYSTEM (KOREN <i>ET AL.</i> 1999). .....	3
FIGURE (1.3) ASPECTS OF RECONFIGURATION FOR A RMS (ADAPTED FROM MEHRABI <i>ET AL.</i> 2000) .....	3
FIGURE (1.4) SYSTEM RECONFIGURATION EXAMPLE (YOUSSEF AND H. ELMARAGHY 2006A). .....	4
FIGURE (2.1) TYPES OF CHANGEABILITY (WIENDAHL AND HEGER, 2003). .....	11
FIGURE (2.2) MANUFACTURING SYSTEM DESIGN DECOMPOSITION (MSDD) (COCHRAN, 2001). .....	13
FIGURE (2.3) ALTERNATIVE SYSTEM CONFIGURATIONS ACCORDING TO SPICER <i>ET AL.</i> , 2002. ....	16
FIGURE (2.4) SYSTEM PERFORMANCE ANALYSIS APPROACH (ZHONG, 2000). .....	17
FIGURE (2.5) AHP USED IN MANUFACTURING SYSTEMS PERFORMANCE EVALUATION (MAIER-SPEREDELOZZI, 2002). .....	17
FIGURE (3.1) AN EXAMPLE OF A SELECTED CONFIGURATION FOR A SPECIFIC CONFIGURATION PERIOD (CP) (YOUSSEF AND H. ELMARAGHY 2006C). .....	25
FIGURE (3.2) EXAMPLE FOR DEMAND SCENARIOS (DSs) AT DIFFERENT CONFIGURATION PERIODS (CPs) (YOUSSEF AND H. ELMARAGHY 2006A). .....	27
FIGURE (3.3) IDEF0 MODEL FOR THE RMS CONFIGURATION SELECTION APPROACH. ....	35
FIGURE (3.4) CONFIGURATION ALTERNATIVES FOR A DEMAND SCENARIO (DS <sub>II</sub> ). .....	36
FIGURE (3.5) A SELECTED SET OF CONFIGURATIONS FOR A SYSTEM WITH ONLY TWO CPs. ....	39
FIGURE (3.6) THE OVERALL RMS CONFIGURATION SELECTION PROCEDURE. ....	40
FIGURE (4.1) STRING REPRESENTATION OF THE ANTICIPATED SOLUTION (THE MULTIPLE-ASPECT CONFIGURATION) (YOUSSEF AND H. ELMARAGHY 2006C). .....	45
FIGURE (4.2) STRING REPRESENTATION OF THE ENCODED MULTIPLE-ASPECT CONFIGURATION (YOUSSEF AND H. ELMARAGHY 2006C). .....	49
FIGURE (4.3) PART ANC-101 AND ITS FEATURES. ....	53

FIGURE (4.4) PART ANC-90 AND ITS FEATURES. ....	54
FIGURE (4.5) GA CONVERGENCE CURVES FOR THREE DIFFERENT RUNS. ....	55
FIGURE (4.6) STRING REPRESENTATIONS OF 9 DISTINCTIVE OPTIMAL CONFIGURATIONS FOR THE CASE STUDY. ....	56
FIGURE (4.7) ONE OF THE OPTIMAL MULTIPLE-ASPECT CONFIGURATIONS FOR THE CASE STUDY (FIRST IN FIGURE 7). ....	56
FIGURE (4.8) M-C-RTS CONVERGENCE CURVES FOR THREE DIFFERENT RUNS. ....	60
FIGURE (5.1) REPRESENTATION OF A SIMPLE MSMS. ....	68
FIGURE (5.2) POSSIBLE CONFIGURATIONS FOR THE SYSTEM. ....	70
FIGURE (5.3) A SAMPLE GA CONVERGENCE CURVE. ....	76
FIGURE (5.4) A SAMPLE NEAR-OPTIMAL CONFIGURATION. ....	76
FIGURE (5.5) A SAMPLE M-C-RTS CONVERGENCE CURVE. ....	77
FIGURE (5.6) A SAMPLE NEAR-OPTIMAL CONFIGURATION. ....	78
FIGURE (5.7) COMPARING RESULTS FOR DIFFERENT CASES OF AVAILABILITY CONSIDERATION. ....	81
FIGURE (5.8) COMPARING NUMBER OF STAGES USED IN BEST OBTAINED NEAR-OPTIMAL CONFIGURATIONS FOR DIFFERENT CASES OF AVAILABILITY CONSIDERATION. ....	82
FIGURE (5.9) COMPARING TOTAL NUMBER OF MACHINES USED IN BEST OBTAINED NEAR- OPTIMAL CONFIGURATIONS FOR DIFFERENT CASES OF AVAILABILITY CONSIDERATION. .....	83
FIGURE (5.10) COMPARING TOTAL NUMBER OF REMOVABLE MODULES USED IN BEST OBTAINED NEAR-OPTIMAL CONFIGURATIONS FOR DIFFERENT CASES OF AVAILABILITY CONSIDERATION. ....	84
FIGURE (6.1) ALTERNATIVE RECONFIGURATION PLANS. ....	103
FIGURE (6.2) TWO POSSIBLE RECONFIGURATION SCENARIOS FOR THE CASE STUDY. ....	107
FIGURE (6.3) THE EFFECT OF ADDING STAGES TO THE SYSTEM ON RS VALUES. ....	111
FIGURE (6.4) THE EFFECT OF ADDING MACHINES TO THE SYSTEM ON RS VALUES. ....	111
FIGURE (6.5) THE EFFECT OF ADDING MACHINE MODULES TO THE SYSTEM ON RS VALUES. .....	112
FIGURE (7.1) AN EXAMPLE OF STOCHASTIC EVALUATION OF RECONFIGURATION SMOOTHNESS (RS) (YOUSSEF AND H. ELMARAGHY 2006A). ....	115

FIGURE (7.2) AN EXAMPLE OF RSA EVALUATION.....	117
FIGURE (7.3) CONFIGURATION C0 OF CP0.....	119
FIGURE (7.4) THE GA CONVERGENCE CURVE. ....	121
FIGURE (7.5) THE FIRST NEAR-OPTIMAL SET OF SELECTED CONFIGURATIONS OBTAINED BY GAS.....	121
FIGURE (7.6) THE SECOND NEAR-OPTIMAL SET OF SELECTED CONFIGURATIONS OBTAINED BY GAS.....	122
FIGURE (7.7) C1 (CONFIGURATION #3 FROM THOSE GENERATED FOR CP1).....	122
FIGURE (7.8) THE RTS CONVERGENCE CURVE.....	125
FIGURE (7.9) THE FIRST NEAR-OPTIMAL SET OF SELECTED CONFIGURATIONS OBTAINED BY RTS.....	125
FIGURE (7.10) THE SECOND NEAR-OPTIMAL SET OF SELECTED CONFIGURATIONS OBTAINED BY RTS.....	126
FIGURE (B.1) OPERATIONS PRECEDENCE GRAPH FOR PART ANC-101. ....	151
FIGURE (B.2) OPERATION CLUSTERS PRECEDENCE GRAPH FOR PART ANC-101. ....	151
FIGURE (B.3) OPERATIONS PRECEDENCE GRAPH FOR PART ANC-90. ....	152
FIGURE (B.4) OPERATION CLUSTERS PRECEDENCE GRAPH FOR PART ANC-90. ....	152
FIGURE (C.1) FLOWCHART OF A STANDARD TS ALGORITHM. ....	159

## LIST OF ABBREVIATIONS

AHP	Analytic Hierarchy Process
C	Configuration
CP	Configuration Period
D	Datum tolerance precedence constraint
DML	Dedicated Manufacturing Lines
DP	Design Parameter
DS	Demand Scenario
FMS	Flexible Manufacturing Systems
FR	Functional Requirement
GA	Genetic Algorithm
HPFL	Homogeneous Paralleling Flow Line
HV-FMS	High Volume Flexible Manufacturing System
ILP	Integer Linear Programming
L	Logical precedence constraint
M	Machine/station
MC	Machine Configuration
M-C-RTS	Modified Continuous Reactive Tabu Search
M-MC	Machine-Machine Configuration
M-MC-OS	Machine-Machine Configuration-Operation Clusters Setup
MRS	Machine-level Reconfiguration Smoothness
MSDD	Manufacturing System Design Decomposition
MSMS	Multi-State Manufacturing System
MSS	Multi-State System
NC	Number of selected Configurations
NMS	Number of Machines per Stage
NSC	Number of selected Sets of Configurations
OC	Operation Cluster
OP	Operation
OS	Operation Clusters Setup

PAMS	Performance Analysis of Manufacturing Systems
PG	Precedence Graph
RI	Relative Importance
RMS	Reconfigurable Manufacturing Systems
RmS	Reconfigurable Machining Systems
RS	Reconfiguration Smoothness
RSL	Reconfiguration Smoothness Limit
RSA	Reconfiguration Smoothness Across
RTS	Reactive Tabu Search
S	Stage
SA	Simulated Annealing
SL	Stage Location
SRS	System-level Reconfiguration Smoothness
TRS	Market-level Reconfiguration Smoothness
TS	Tabu Search
UGF	Universal Generating Function

## NOMENCLATURE

- NCP* number of configuration periods (CPs) considered
- $T[1, \dots, NCP]$  vector representing the duration (in years) of each configuration period where  $T(cp)$  is the duration of configuration period  $cp$  and  $cp$  is the index for configuration periods,  $cp = 1, \dots, NCP$
- $NDS[1, \dots, NCP]$  vector representing the number of demand scenarios for each configuration period where  $NDS(cp)$  is the number of demand scenarios in configuration period  $cp$  and  $NDS(1) = 1$  (there is only one deterministic DS for the first CP)
- TNP* total number of part types to be produced in the planning horizon
- $DS_{cp, ds}[1, \dots, (TNP+1)]$  vector to give information about demand scenario  $ds$  during configuration period  $cp \forall ds = 1, \dots, NDS(cp) \forall cp = 1, \dots, NCP$  where  $DS_{cp, ds}(p)$  is the demand rate required for part  $p$  in demand scenario  $ds$  during configuration period  $cp$  and  $p$  is the index for parts,  $p = 1, \dots, TNP$  and  $DS_{cp, ds}(TNP+1)$  is the probability of occurrence of demand scenario  $ds$  during configuration period  $cp$
- $RI[1, \dots, NCP]$  vector representing the relative importance for each configuration period in the evaluation of the RS across all CPs which reflects the relevance of the information provided in the DSs for each period where  $RI(cp)$  is the relative importance of configuration period  $cp$  and  $\sum_{cp=1}^{NCP} RI(cp) = 1$
- $NOP[1, \dots, NP]$  vector representing the number of operations (OPs) required to produce each part where  $NOP(p)$  is the number of operations required to produce part  $p$  and  $p$  is the index for parts,  $p = 1, \dots, NP$
- $OPID_p[1, \dots, NOP(p)]$  vector representing the ID's of the OPs required to produce each part  $p$  where  $OPID_p(x)$  is the ID of  $OP_x$  required to produce part  $p$
- $OPP_p[1, \dots, NOP(p)]$  matrix to represent operations precedence relations of part  $p \forall p [1, \dots, NOP(p)] = 1, \dots, NP$  where
- $$OPP_p(x, y) = \begin{cases} 1, & \text{if } OP_x \text{ must be performed before } OP_y \text{ for part } p \\ 2, & \text{if } OP_x \text{ must be performed (clustered) with } OP_y \text{ for part } p \\ 0, & \text{otherwise} \end{cases}$$
- where  $x, y$  are the indices for operations,  $x, y = 1, \dots, NOP(p)$

- $NOC[1, \dots, NP]$  vector representing the number of operation clusters (OCs) required to produce each part where  $NOC(p)$  is the number of operation clusters (OCs) required to produce part  $p$
- $OCID_p[1, \dots, NOP(p)]$  vector representing the ID's of the OCs required to produce each part  $p$  where  $OCID_p(i)$  is the ID of  $OC_i$  required to produce part  $p$
- $NOPC_p[1, \dots, NOC(p)]$  vector representing the number of OPs in each OC for part  $p \forall p = 1, \dots, NP$  where  $NOPC_p(i)$  is the number of OPs in operation cluster  $i$  for part  $p$  and  $i$  is the index for operation clusters,  $i = 1, \dots, NOC(p)$
- $OPC_p[1, \dots, NOC(p)]$  matrix to give information about the OPs of which each OC is composed for part  $p \forall p = 1, \dots, NP$  where
- $$OPC_p(i, y) = \begin{cases} 1, & \text{if } OP_y \text{ is a component of } OC_i \text{ for part } p \\ 0, & \text{otherwise} \end{cases}$$
- $OCP_p[1, \dots, NOC(p)]$  matrix to represent operation clusters precedence relations of part  $p \forall p = 1, \dots, NP$  where
- $$OCP_p(i, j) = \begin{cases} 1, & \text{if } OC_i \text{ must be performed before } OC_j \text{ for part } p \\ 0, & \text{otherwise} \end{cases}$$
- where  $i, j$  are the indices for operation clusters,  $i, j = 1, \dots, NOC(p)$
- $NOS[1, \dots, NP]$  vector representing the number of operation clusters setups (OSs) for each part where  $NOS(p)$  is the number of possible operation clusters setups (OSs) for part  $p$
- $OSID_p[1, \dots, NOS(p)]$  vector representing the ID's of the OSs for each part  $p$  where  $OSID_p(i)$  is the ID of  $OS_u$  for part  $p$
- $NOCS_p[1, \dots, NOS(p)]$  vector representing the number of OCs in each OS for part  $p \forall p = 1, \dots, NP$  where  $NOCS_p(u)$  is the number of OCs in operation clusters setup  $u$  for part  $p$  and  $u$  is the index for operation clusters setups,  $u = 1, \dots, NOS(p)$
- $OCS_p[1, \dots, NOS(p)]$  matrix to give information about the OCs of which each OS is composed for part  $p \forall p = 1, \dots, NP$  where
- $$OCS_p(u, j) = \begin{cases} 1, & \text{if } OC_j \text{ is a component of } OS_u \text{ for part } p \\ 0, & \text{otherwise} \end{cases}$$
- $OSP_p[1, \dots, NOS(p)]$  matrix to represent operation clusters setups precedence and feasibility of grouping relations of part  $p \forall p = 1, \dots, NP$  where



$$OSP_p(u, v) = \begin{cases} 1, & \text{if } OSu \text{ must be performed before } OSv \text{ for part } p \\ 2, & \text{if } OSu \text{ cannot be grouped with } OSv \text{ (common OCs) for part } p \\ 0, & \text{otherwise} \end{cases}$$

where  $u, v$  are the indices for operation clusters setups,  $u, v = 1, \dots, NOS(p)$

$NM$  number of available/obtainable reconfigurable machine types

$NMC[1, \dots, NM]$  vector representing the number of possible machine configurations (MCs) that can be used with each machine type where  $NMC(m)$  is the number of possible machine configurations (MCs) that can be used with machine type  $m$  and  $m$  is the index for machines,  $m = 1, \dots, NM$

$CMC_m[1, \dots, NMC(m)]$  vector representing the initial cost of all possible MCs for machine  $m \forall m = 1, \dots, NM$  where  $CMC_m(c)$  is the Initial cost of machine configuration  $mc$  for machine  $m$  and  $c$  is the index for machine configurations,  $c = 1, \dots, NMC(m)$ .  $CMC_m$  includes cost of machine basic structure, modules for axes of motion, spindle modules and fixture modules

$D$  the depreciation rate for the equipment used in the configuration

$I$  annual interest rate

$AMC_m[1, \dots, NMC(m)]$  vector representing the machine steady-state availability of all possible MCs for machine  $m \forall m = 1, \dots, NM$  where  $AMC_m(c)$  is the steady-state availability of machine configuration  $c$  for machine  $m$

$NRM_m[1, \dots, NMC(m)]$  vector representing the number of removable modules of all possible MCs for machine  $m \forall m = 1, \dots, NM$  where  $NRM_m(c)$  is the number of removable modules of machine configuration  $c$  for machine  $m$

$DRM_m[1, \dots, NMC(m)]$  matrix to represent the number of modules added and/or removed to/from machine  $m$  to change from one configuration to another  $\forall m = 1, \dots, NM$  where  $DRM_m(c, d)$  is the number of modules added to machine  $m$  to change from configuration  $c$  to configuration  $d$  or number of modules removed from machine  $m$  to change from configuration  $d$  to configuration  $c$  and  $c, d$  are the indices for machine configurations,  $c, d = 1, \dots, NMC(m)$

$FOS_{p,m}[1, \dots, NOS(p)]$  matrix to provide information about the feasibility of producing  
 $[1, \dots, NMC(m)]$  each possible operation clusters setup for part  $p$  using possible configurations of machine  $m \forall m = 1, \dots, NM \forall p = 1, \dots, NP$  where

$$FOS_{p,m}(u, c) = \begin{cases} 1, & \text{if feasible} \\ 0, & \text{if not feasible} \end{cases}$$

where  $u$  is the index for operation clusters setup,  $u = 1, \dots, NOS(p)$  and  $c$  is the index for machine configurations,  $c = 1, \dots, NMC(m)$

$TOS_{p,m}[1, \dots, NOS(p)]$  matrix to provide the standard time (in seconds) required to  
 $[1, \dots, NMC(m)]$  produce each possible operation clusters setup for part  $p$  using feasible configurations of machine  $m \forall m = 1, \dots, NM \forall p = 1, \dots, NP$  where

$$TOS_{p,m}(u, c) = \begin{cases} \text{Standard time to produce OSu} \\ \text{using Mm with MCc for part } p, & \text{if feasible} \\ 0, & \text{if not feasible} \end{cases}$$

$PROS_{p,m}[1, \dots, NOS(p)]$  matrix to provide the production rate (in parts/hr) of producing  
 $[1, \dots, NMC(m)]$  each possible operation clusters setup for part  $p$  using feasible configurations of machine  $m \forall m = 1, \dots, NM \forall p = 1, \dots, NP$  where

$$PROS_{p,m}(u, c) = \begin{cases} \text{Production rate to produce OSu} \\ \text{using Mm with MCc for part } p, & \text{if feasible} \\ 0, & \text{if not feasible} \end{cases}$$

$NSL$  number of available stage locations (maximum number of stages)

$MMS$  maximum number of parallel machines per stage

$MI$  maximum allowable initial investment in the configuration (machines, axes, spindles and fixtures)

$NS$  number of stages

$M[1, \dots, NS]$  vector representing the machine type allocated to each stage where  $M(s)$  is the machine type allocated to stage  $s$  and  $s$  is the index for stages,  $s = 1, \dots, NS$

$MC[1, \dots, NS]$  vector representing the machine configuration selected for the machine type in each stage where  $MC(s)$  is the machine configuration selected for machine type  $M(s)$  in stage  $s$

$NMS[1, \dots, NS]$  vector representing the number of identical parallel machines in each stage where  $NMS(s)$  is the number of identical parallel machines of type  $M(s)$  in stage  $s$

$OS_p[1, \dots, NS]$  vector representing the operation clusters setup assigned to the machines in each stage for part  $p \forall p = 1, \dots, NP$  where

$$OS_p(s) = \begin{cases} OS \text{ assigned to machines in stage } s, & \text{if stage } s \text{ is used for part } p \\ 0, & \text{if stage } s \text{ is not used for part } p \end{cases}$$

$SL[1, \dots, NS]$  vector representing the location of each stage where  $SL(s)$  is the location of stage  $s$

# 1. INTRODUCTION

This chapter gives a brief review of the current types of manufacturing systems including reconfigurable manufacturing systems (RMS), the motivation behind the presented research, the objectives, the approach followed and an overview of the dissertation.

## 1.1 Overview of Manufacturing Systems

Manufacturing systems have evolved over the years in response to an increasingly dynamic and global market with greater need for flexibility and responsiveness (Figure 1.1).

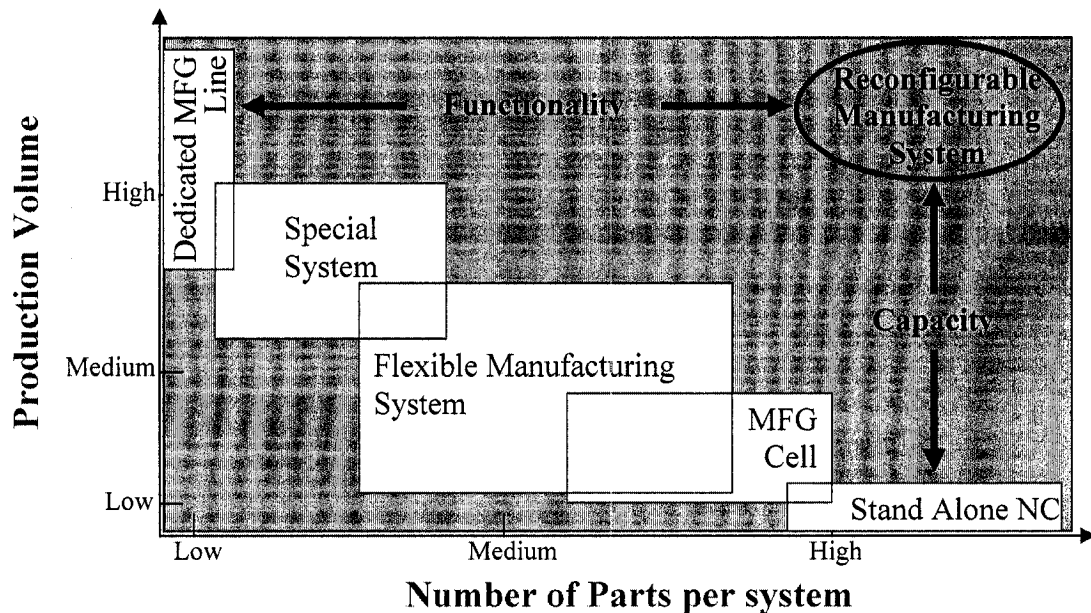

Figure (1.1) Functionality and capacity of manufacturing systems (Youssef and H. ElMaraghy 2006a).

Most manufacturing industries now use a portfolio of dedicated manufacturing lines (DML) and Flexible Manufacturing Systems (FMS) to produce their products. The comparison between the two types of systems shown in Table 1.1 identifies key limitations in both types (Koren *et al.* 1999).

Table (1.1) Comparison between DML and FMS (Koren *et al.* 1999).

	D M L	F M S
<b>Limitations</b>	<ul style="list-style-type: none"> <li>• Not flexible (single product)</li> <li>• Not scalable (fixed capacity)</li> </ul>	<ul style="list-style-type: none"> <li>• Expensive (machine focus)</li> <li>• Low throughput (single-tool machines)</li> </ul>
<b>Advantages</b>	<ul style="list-style-type: none"> <li>• Low cost</li> <li>• Multi-tool operation</li> </ul>	<ul style="list-style-type: none"> <li>• Flexible</li> <li>• Scalable</li> </ul>

Unpredictable market changes lead to frequently changing requirements to the manufacturing systems. Reconfigurable Manufacturing Systems (RMS) were proposed to meet these requirements and provide a degree of capacity scalability and functional adaptability (Figure 1.1). The characteristics of RMS and FMS are outlined and both paradigms are compared in (H. ElMaraghy 2006).

## 1.2 Reconfigurable Manufacturing Systems (RMS)

The USA's National Research Council, in a study entitled "*Visionary Manufacturing Challenges for 2020*", identified Reconfigurable Manufacturing Systems as the number one priority technology in manufacturing for the year 2020 (Bollinger *et al.* 1998). The study also lists Reconfigurable Manufacturing Enterprises as one of the Six Grand Challenges for the future of manufacturing.

Koren *et al.* (1999) defined RMS as follows:

"A Reconfigurable Manufacturing System (RMS) is designed at the outset for rapid change in structure, as well as in hardware and software components, in order to quickly adjust production capacity and functionality within a part family in response to sudden changes in market or in regulatory requirement."

RMS is intended to combine the high throughput of DML with the flexibility of FMS and react to changes quickly and efficiently. Figure 1.2 illustrates how RMS provides the functionality and capacity needed, when it is needed (Koren *et al.* 1999).

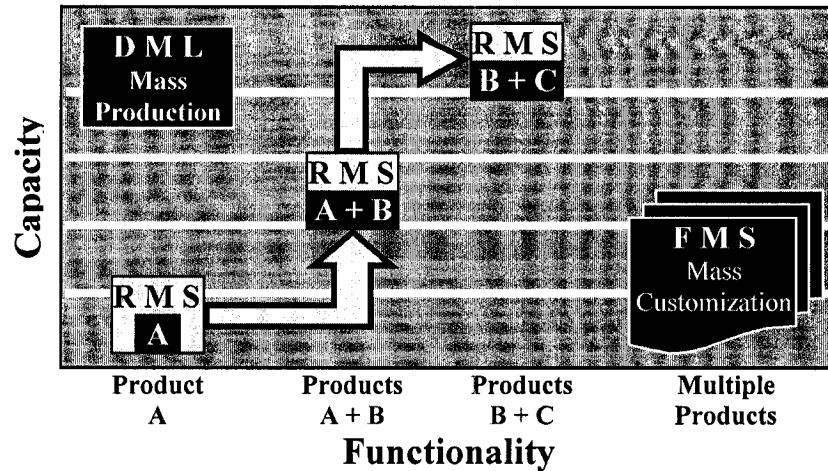

Figure (1.2) Both DML and FMS are static systems, while a RMS is a dynamic system (Koren *et al.* 1999).

There are many aspects of manufacturing system reconfiguration that present important research and practical challenges (Figure 1.3). These include reconfiguration of the factory software, configuration of new machine controllers, building blocks and configuration of modular machines, modular processes and configuration of the production system (Mehrabi *et al.* 2000). The main focus of the research reported in this dissertation is the selection of system-level configurations.

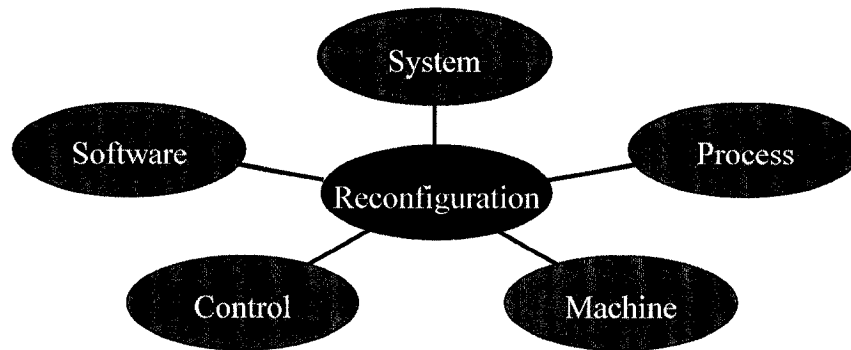

Figure (1.3) Aspects of reconfiguration for a RMS (adapted from Mehrabi *et al.* 2000)

### 1.3 Motivation

A distinguishing feature of RMS from other manufacturing systems is its ability to change configurations in order to provide the functionality and capacity needed, when it is needed. These configuration changes can be in the form of; adding/removing machines/stations to/from the system, adding/removing axes/spindles to/from machine tools, changing configuration of machine tools (Landers *et al.* 2001), changing the system



layout, or changing the material handling systems. Figure 1.4 shows an example of system reconfiguration.

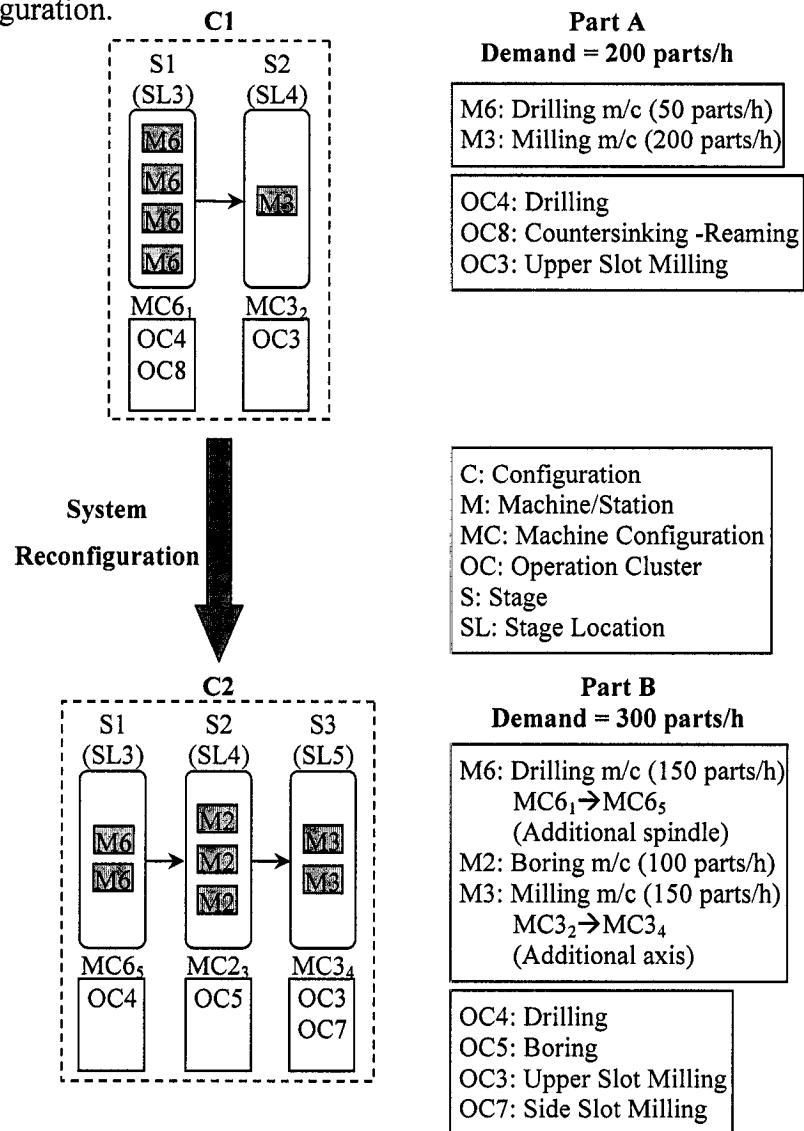

Figure (1.4) System reconfiguration example (Youssef and H. ElMaraghy 2006a).

It is desirable to change manufacturing system configuration when demand changes in order to minimize the unused capacity and functionality. In addition, there should be a high degree of reconfiguration smoothness between each two consecutive configurations in order to minimize the cost, time and effort of reconfiguring the system. Therefore, there is a need for an approach for selecting the RMS configuration according to the current situation, in terms of demand requirements, targeting the best achievable system performance levels while taking into consideration the smoothness of the anticipated reconfiguration process from one configuration to the next expected configuration.

## 1.4 Objectives and Approach

The objective of the presented research work is to develop an approach for selecting RMS configurations that provide optimal performance and maintain the highest level of reconfiguration smoothness according to anticipated future demand requirements.

A selected system configuration can be exemplified by any of the two configurations shown in Figure 1.4. The system evaluation criteria to be determined for the system include capital cost of RMS configurations and the system availability. The level of reconfiguration smoothness between configurations is measured through a reconfiguration smoothness metric that was developed as a part of this work.

The objective of RMS is to provide the capacity and functionality needed when needed with least amount of reconfiguration effort. The purpose of this thesis is:

*to show that the use of stochastic analysis and rules-guided planning for the anticipated reconfiguration process in the optimal selection of multiple-aspect RMS configurations, capable of producing multiple-part types simultaneously, achieves the RMS objective.*

The goal of this thesis is achieved using a novel two-stage “RMS Configuration Selection Approach” within the following scope:

1. RMS configurations are capable of producing multiple-parts simultaneously and their structure is that of a flow line allowing paralleling of identical machines in each production stage.
2. The considered RMS configurations have multiple-aspects including arrangement of machines (number of stages and number of parallel machines per stage), equipment selection (machine type and corresponding machine configuration for each stage) and assignment of operations (operation clusters assigned to each stage corresponding to each part type).
3. The planning horizon of a RMS considers more than one configuration period (CP) each of which has either a deterministic demand scenario (DS) in case of the



current period of interest or a set of possible stochastic DSs with probabilities of occurrence in case of future anticipated periods.

The RMS Configuration Selection Approach has the following two stages:

1. The first stage deals with the selection of near-optimal alternative system configurations for each possible demand scenario over the considered configuration periods. It optimizes given system evaluation criteria (capital cost and system availability) regardless of the anticipated degree of transition smoothness between consecutive configurations as follows:
  - a. A model is formulated for optimizing the capital cost of multiple-aspect RMS configurations without considering the effect of machines downtimes (availability of individual machines is assumed to be 100%). Capital cost of a RMS configuration during a configuration period represents the cost of depreciating the machines used in that configuration taking into consideration their corresponding machine configurations and the duration of this period.
  - b. A constraint satisfaction procedure is developed for generating feasible RMS configurations according to the demand requirements of each DS. It overcomes the complexity of the search space by mapping from the discrete domain of the decision variables to a continuous domain of variables that guarantees the feasibility of the generated alternatives.
  - c. Genetic Algorithms (GAs) that suite the nature of the new continuous domain of variables are used to guide the optimization process. It generates a predefined number of near-optimal alternative configurations within a predefined tolerance limit.
  - d. A variant of Tabu Search (TS), known as Modified Continuous Reactive Tabu Search (M-C-RTS), is utilized with the same optimization problem to validate the results of the GAs. The performances of both meta-heuristic optimization techniques are compared with regards to quality of results and time consumed in the optimization process.

- e. The Universal Generating Function (UGF) technique is used for performance evaluation of multi-state manufacturing systems (manufacturing systems for which machines downtimes are incorporated in the analysis). The original UGF is modified to generalize its use and extend it to systems with multiple types of output performance. The modified UGF technique is utilized in evaluating both the steady-state availability and expected production rates of RMS configurations capable of producing multiple part types simultaneously.
  - f. The optimization model in step (a) is then modified to consider the effect of machines downtimes (availability of individual machines) based on the model in step (e). The modified model is used for optimizing capital cost and system availability of RMS configurations. The effect of incorporating availability of individual machines on the optimization results is analyzed for different cases (infinite buffer capacity and no buffer capacity) and compared to the results in the case of not incorporating availability.
2. The second stage determines the alternatives, from those produced in the first stage, for all possible demand scenarios (DSs) that would optimize the degree of transition smoothness over the planning horizon as follows:
- a. A reconfiguration smoothness (RS) metric, that provides a relative indication of the effort, time and cost required to convert the system from one configuration to another, is developed.
  - b. Reconfiguration planning rules are introduced to help determine the exact locations for the different production stages within the flow line configuration structure. In addition, these rules guide the development of execution plans for system-level reconfiguration. These plans as well as the selected stage locations help reduce the physical effort of reconfiguring the system.
  - c. A procedure is developed for automatically determining the exact locations for the different production stages and developing detailed step-by-step execution plans for reconfiguration based on the reconfiguration

planning rules. This prevents human interventions based on subjective decisions.

- d. A model, based on the RS metric and the reconfiguration planning rules, is developed for the stochastic evaluation of the level of reconfiguration smoothness across all the configuration periods in the planning horizon. This evaluation depends on the probabilities of occurrence of the different anticipated demand scenarios and the relative importance of each configuration period which reflects the reliability of the anticipated information of its corresponding DSs.
  - e. Genetic Algorithms (GAs) are utilized for optimizing the level of reconfiguration smoothness across all the configuration periods in the planning horizon based on the model in the previous step (c). This is a discrete optimization process in which the different demand scenarios (DSs) are treated as the decision variables for which the domains of values are the alternative configurations provided for each DS from the first stage of the approach. The GAs generates a predefined number of near-optimal alternative sets of configurations, within a predefined tolerance limit, corresponding to the different anticipated DSs. Each set of configurations includes the selected configuration for the first configuration period, the period of interest.
  - f. A variant of Tabu Search (TS), known as Reactive Tabu Search (RTS), is utilized with the same optimization problem to validate the results of the GAs. The performances of both meta-heuristic optimization techniques are compared with regards to quality of results and time consumed in the optimization process.
3. A case study is presented to demonstrate the use of the developed approach and verify the results obtained in each of the above-mentioned steps.
  4. All procedures, algorithms, curves and graphs were developed using MATLAB software.

## 1.5 Overview of the Dissertation

This dissertation is composed of eight chapters and five appendices, the remainder of which is organized as follows:

- Chapter two presents a review of the related literature highlighting the gaps in this area of research.
- Chapter three presents the RMS Configuration Selection Approach. The chapter starts with the basic assumptions related to the problem definition, the input and output, and ends with an overall description of the approach.
- Chapter four provides a model for optimizing capital cost of RMS configurations without considering machine availability. A constraint satisfaction procedure is presented and the use of GAs and M-C-RTS to solve the optimization problem is described. The model is verified using a case study based on an example part from the literature. The results of both optimization techniques are presented, analyzed and compared for validation.
- Chapter five describes the use of the UGF in the assessment of steady-state availability and expected production rates of multi-state manufacturing systems (MSMS) capable of producing multiple-part types. The chapter then presents a modification to the model provided in Chapter four to incorporate machine availability. The results of using both GAs and M-C-RTS are again reported for the modified model after being applied to the same case study. Analysis of different cases of availability consideration (infinite buffer capacity and no buffer capacity) is performed and results are compared to the case of not considering machine availability. The first stage of the approach is concluded.
- Chapter six presents a detailed description of the developed RS metric and reconfiguration planning rules and the procedure developed for reconfiguration planning. An example is provided for demonstrating the use of both the metric and the rules followed by their application to the case study. The chapter concludes with sensitivity analysis and a discussion of results.
- Chapter seven provides a stochastic model for optimizing the level of reconfiguration smoothness across all the configuration periods in the planning

horizon. The utilization of GAs and RTS to solve this discrete optimization problem is presented and applied to the case study based on the outcome results of the first stage of the approach. The overall results of the proposed approach are presented followed by a discussion.

- Chapter eight concludes the dissertation, highlights the scientific contributions and provides suggestions for future research.

The dissertation has five appendices. Appendix A provides a brief description of GAs and its operators. Appendix B provides the machine processing information of the example parts used in the case study and a description of the available resources. Appendix C gives a brief account on the use of TS and its variants, RTS and M-CRTS, in optimization. Appendix D gives a description of the UGF technique. Appendix E presents a sample of the results report as generated by the tool developed for the overall approach.

## 2. LITERATURE REVIEW

This chapter provides a review of the literature related to the design and selection of system configurations in the context of Reconfigurable Manufacturing Systems and highlights the gaps in this area of research.

### 2.1 Introduction

Wiendahl and Heger (2003) identified reconfigurability as one of five types of changeability of a manufacturing system (Figure 2.1). They defined reconfigurability as the practical ability of the system to switch reactively and with minimal effort and delay to a particular number of workpieces or subassemblies through the addition or removal of single functional elements.

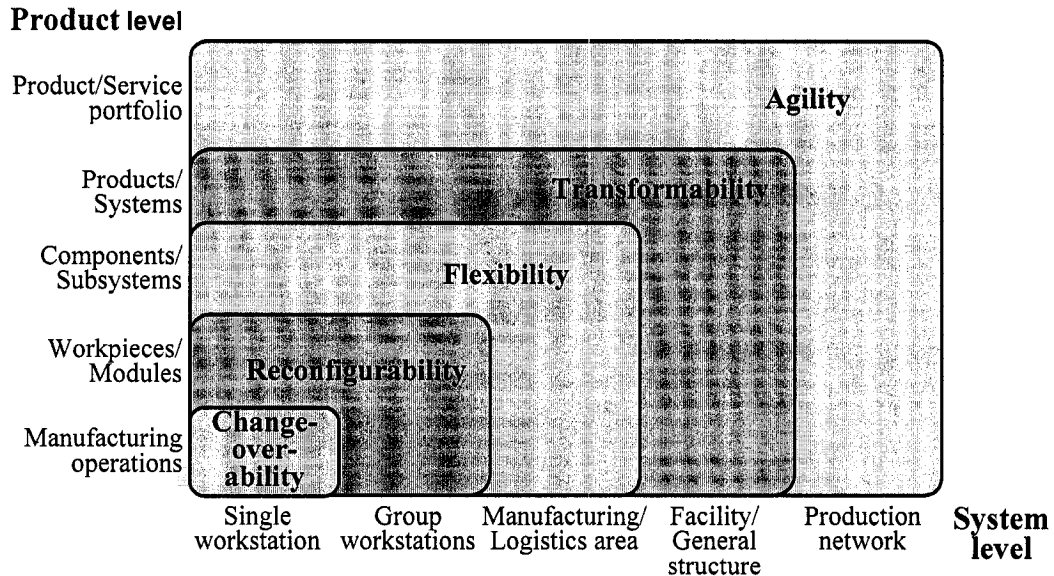

Figure (2.1) Types of changeability (Wiendahl and Heger, 2003).

Makino and Trai (1994) classified reconfigurable systems into two categories: statically reconfigurable systems, which are based on the concept of building blocks, where the stations of the system are designed to be easily moved around, and dynamically reconfigurable systems, which attain their reconfigurability by using advanced material handling systems like automated guided vehicles (AGVs) or traveling robots rather than the use of traditional conveyor systems.



Kusiak and Lee (1995) and Lee (1997, 1998) discussed reconfigurability in the design of products and manufacturing systems. They defined reconfigurability as the ability of a manufacturing system to be reconfigured at a low cost and in a short period of time. They introduced rules to be applied in the early stages of system design in order to minimize the number of machine relocations. However, they focused on appropriate product design as a means of attaining reconfigurability.

H. ElMaraghy (2002, 2006) divided manufacturing systems reconfiguration activities into two types: hard and soft. Examples of hard (physical) reconfiguration activities include adding/removing of machines, adding/removing of machine modules and changing material handling systems. Examples of soft (logical) reconfiguration activities include re-programming of machines, re-planning, re-scheduling, re-routing and increasing/decreasing of shifts or number of workers.

Kimms (2000) presented a mathematical model formulation for the investment minimization of a flow line configuration, which was defined as the number of stages and the equipment in these stages that can handle multiple parts. It focuses only on the functional requirements of the system and does not consider the capacity requirements, which affect the configuration selection decisions.

Kuo (2001) and Yamada *et al.* (2003) optimized the equipment layout assignment for RMS with the objective of minimizing the total transportation time. Kuo (2001) used distributed colored timed Petri net (DCTPN) to model the RMS while Yamada *et al.* (2003) used an algorithm based on particle swarm optimization (PSO).

Abdi and Labib (2003a, b, 2004) discussed strategic issues of system design and products grouping and selection. They introduced an analytical hierarchical process (AHP) model for designing RMSs based on a case study. They focused on decisions regarding selecting the system type followed by the grouping of products into families and selecting a family for each system configuration.

Tesfamariam Semere (2005) provides a comprehensive review of the methods that can be used in the different design stages for responsive manufacturing systems. The

author identified quality, time, dependability, flexibility and cost as important objectives for evaluating alternative system configurations and applied simulation based on system dynamics to investigate the suitability of an existing system configuration and its control policy to the manufacturing strategic objectives using a case study.

The following sections provide an in depth review of the approaches that dealt with the selection of systems configuration in the RMS context in addition to other research work that might be adopted to solve this problem.

## 2.2 Manufacturing System Design Decomposition (MSDD)

Cochran *et al.* (2001) integrated the axiomatic design approach with the concepts of several design frameworks and developed the Manufacturing System Design Decomposition (MSDD) approach (Figure 2.2). This approach can link the high-level objectives of a system to the operational level decision making process to guarantee that every operational design parameter is consistent with the higher-level objectives. The decomposition process proceeds through zigzagging between functional requirements (FRs) and design parameters (DPs) for as long as it is possible to do so without limiting its usefulness.

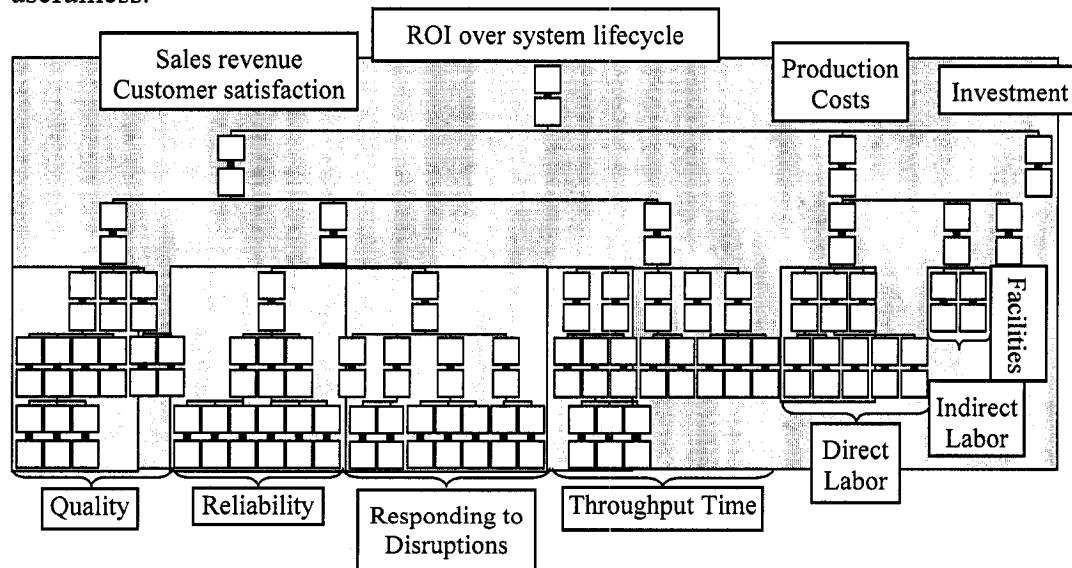

Figure (2.2) Manufacturing System Design Decomposition (MSDD) (Cochran, 2001).

This approach is difficult to apply to the problem at hand for the following reasons: First, it does not consider optimization and enhancement of the performance of the



manufacturing system because the main concern is to achieve a feasible system design within defined constraints (preset objectives). The incorporation of the level of reconfiguration smoothness makes it even harder to set this predetermined objectives. In addition, this approach needs extensive and subjective human input to determine the FRs and DPs, which has to be repeated at the beginning of each configuration period in the context of RMS. Therefore, MSDD helps in system design synthesis with prespecified objectives rather than seeking optimal performance, which makes it unsuitable for application to the problem at hand.

### **2.3 Stochastic Hierarchical Approach**

Matta *et al.* (2001) proposed a stochastic hierarchical approach for supporting firms in their decisions for configuring automated production systems. The problem is decomposed into different sub-problems. In each sub-problem, the production system is represented with a specified level of detail and accuracy that increases from the top of the hierarchy to the bottom. At higher levels, the system is modeled taking into account a limited number of decision variables, in particular, those that have a major impact on the system behavior so that it is possible to be solved using approximate analytical methods. At lower levels of the hierarchy, after discarding the non-promising alternatives, the system is represented in detail, taking into account other decision variables that are less important in addition to those already considered in the higher levels. Simulation can, then, be used to analyze the remaining alternatives in order to achieve the desired level of accuracy.

It is assumed that the level of impact, major or minor, of the different decision variables on the system performance is known before hand, which is difficult to predict especially when taking into consideration different forms of performance measures. In addition, no mechanism for generating alternative configurations was offered, which can be done by meta-heuristic optimization techniques such as Tabu Search (TS), Genetic Algorithms (GAs) or Simulated Annealing (SA). These techniques can offer a large pool of alternatives for the system configurations to be considered and can be very efficient in

handling a high degree of details for the problem. A good review of these methods is given by Pham and Karaboga (2000).

## **2.4 Evolution-Based Planning System**

Toenshoff *et al.* (2001) introduced a methodology, which uses evolutionary algorithms for the investigation of an optimized manufacturing system configuration. Different alternative variations are created by an evolution-based algorithm, using crossover and mutation, from a given start configuration, which is described in a genetic vector. Each of the new configurations is tested in a simulation environment and rated according to the user requirements. Only the best solutions for the required manufacturing system are used to continue with the evolution process until the ratings reach pre-defined stopping criteria.

## **2.5 A Framework for a Stochastic Model of a RMS**

Xiaobo *et al.* (2000a) proposed a framework for a stochastic model of a RMS. This framework involves three issues identified by the authors as the most important, namely; the optimal configurations in the design stage, the optimal selection policy in the utilization stage, and the performance measure to be used in improving these systems. They stated that a Reconfigurable Manufacturing System (RMS) manages to satisfy customers, with each family of products corresponding to one configuration of the RMS.

Xiaobo *et al.* (2000b) formulated the problem of selecting the optimal configuration for each product, based on their stochastic model, and devised two algorithms to solve it. They also formulated the selection of the product family to be produced next by the RMS as an optimization problem and devised two procedures to solve it (Xiaobo *et al.* 2001a). A semi-Markov process for obtaining the performance measure of a RMS according to the service levels of different product families was formulated and two solution approaches were proposed (Xiaobo *et al.* 2001b).

Ohiro *et al.* (2003) proposed a modification to improve the work done by Xiaobo *et al.* (2000a, b, 2001a, b) through involving the overall state of the system, regarding the quantity of orders, in choosing the best configuration instead of associating each product

family with only a single optimal configuration regardless of the system state. The results in (Ohiro *et al.* 2003) show the superiority of their model.

This approach does not address the information needed to define a configuration and assess its feasibility for a certain product family. These types of information are essential for choosing optimal feasible configurations for each product family. The main focus of this research direction is to maximize the anticipated profit and the only considered measure of performance is the service levels for the families as if it is only an assignment or scheduling problem. There are other performance criteria, on the system level, for Reconfigurable Manufacturing Systems that are influenced by the system configuration selection policy and has to be put into consideration such as production rate (throughput), system availability, ...etc. In addition, this work neglects the effect of the configuration selection on the smoothness and easiness of the subsequent reconfiguration process, which has to be taken into consideration especially when dealing with RMS.

## 2.6 System Performance Analysis Approach

Spicer *et al.* (2002a) defined machining system configuration as the arrangement of the machines (parallel, series, hybrid, ...etc.) and the interconnections among them (with or without crossover) (Figure 2.3). They showed that, for the same number of machines, pure parallel configurations have the best throughput and scalability performance but with more quality streams than other types of configurations.

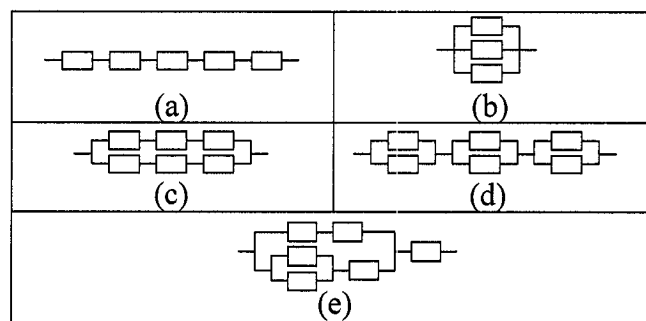

Figure (2.3) Alternative system configurations according to Spicer *et al.*, 2002.

Koren *et al.* (1998) used the same system configuration definition as Spicer *et al.* (2002a), to demonstrate that the system configuration has a significant impact on six key

performance criteria; investment cost of machines and tools, quality, throughput, capacity scalability, number of product types and system conversion time. Yang and Hu (2000a) studied the effect of different configurations (parallel, series, ...etc.) on the system productivity using machine level reliability models for a six CNC machine manufacturing system. Maier-Sperdelozzi *et al.* (2003) studied the effect of different configurations on the manufacturing systems convertibility after developing convertibility metrics for manufacturing systems. Zhong *et al.* (2000) presented methodologies for evaluating system performance with respect to productivity, quality, scalability, and convertibility for different machining system configurations as shown in Figure 2.4.

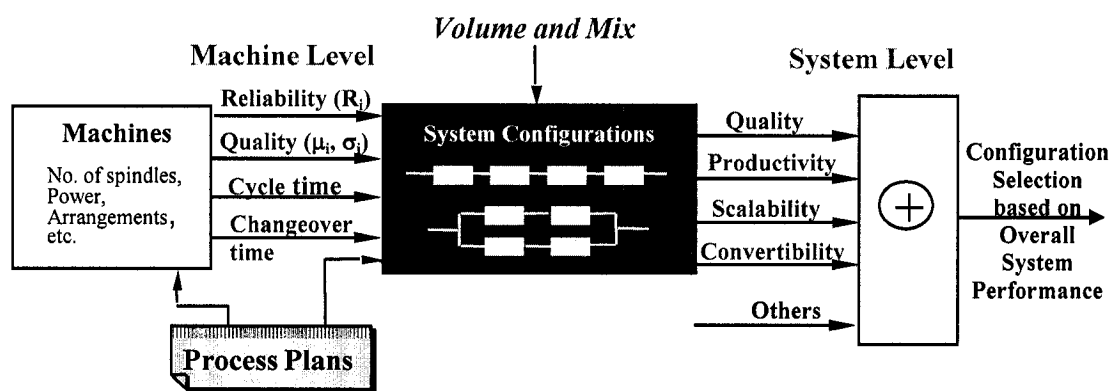

Figure (2.4) System Performance Analysis Approach (Zhong, 2000).

Maier-Sperdelozzi and Hu (2002) adapted the Analytic Hierarchy Process (AHP) for use in problems where manufacturing system configurations are selected considering multiple performance criteria (Figure 2.5).

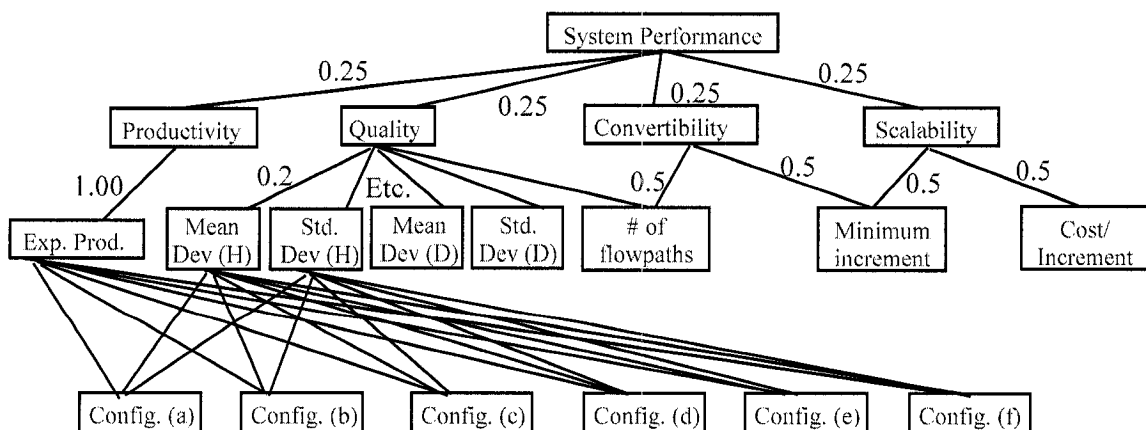

Figure (2.5) AHP used in manufacturing systems performance evaluation (Maier-Sperdelozzi, 2002).

The trend in the work done by this research work tends to narrow the scope of the system configuration definition to just the physical machine arrangement (parallel, series, hybrid, ...etc.). This scope should be widened to include other important aspects of the configuration such as the number of production stages, the equipment selection (machine type and corresponding machine configuration for each stage), the assignment of operations (operation clusters assigned to each stage corresponding to each part type) as well as the material handling systems. These additional configuration aspects have a great influence on the overall system performance and consequently on the configuration selection decisions. In addition, this work neglects the effect of the configuration selection on the smoothness and easiness of the subsequent reconfiguration process, which is essential as mentioned earlier.

## 2.7 Multi-Part Optimal Line Design

Tang *et al.* (2004) introduced an approach that couples line-balancing, machine selection and throughput analysis for designing manufacturing lines that produce multiple parts. They utilized a Genetic Algorithm formulation to capture the configuration and task allocation for a multiple-parts line and used the minimal ratio of cost to throughput as the criterion for the fitness function. They utilized a throughput analysis engine; namely Performance Analysis of Manufacturing Systems (PAMS), which is based on the work done by Yang *et al.* (2000b). Tang *et al.* (2005) used this approach to prove that for the same number of machines, the multiple parts manufacturing system is better than the traditional single part manufacturing system in terms of system cost.

The work done does not consider the effect of the configuration selection on the smoothness and easiness of the reconfiguration process. In addition, this work only deals with deterministic analysis, which is not sufficient and will affect the evaluation of the alternative configurations from the perspective of smoothness of reconfiguration if taken into consideration. It is assumed that the designer predefines the number of production stages and that every part must visit all the stages in the system. These assumptions simplify the problem but affect the quality of the results by ignoring other possibilities for the system configuration.

## 2.8 Alternative Configuration Path Generation

Son (2000a) and Son *et al.* (2000b) developed a methodology to design economical Reconfigurable Machining Systems (RmSs), given a deterministic demand scenario for the early stage of configuration design. This methodology generates configuration paths for changing demand by considering reconfigurations between demand periods, using a configuration similarity index, as well as the cost efficiencies for each demand period utilizing Genetic Algorithms (GAs). The index used is based on the level of similarity between any two consecutive configurations and is divided into three components; resource similarity defining commonality in resources between the two configurations, structural similarity defining the precedence relationship between operations and operation similarity defining operation assignments to stations.

This work focuses only on the cost benefits and economic evaluation of the different system configurations that are generated neglecting other important performance criteria on the system level as mentioned earlier. Relying on deterministic analysis is not sufficient when dealing with such a changing environment and expectations of some different scenarios that might occur. In addition, the configuration similarity index defined, although promising, has to be enhanced to be more reflective of the cost, time and effort of reconfiguration as it is lacking many important elements that would affect the cost and effort of the physical reconfiguration process such as the number of machines to be relocated (not just the difference in the number of machines being used), number of machine modules to be added or removed from the system and the number of flow paths between different stages. This index, also, does not reflect the different levels of reconfiguration such as machine-level, system-level and market-level, which will affect the influence of each component on the index evaluation. Finally, this work considers only single product demand scenarios. The consideration of multi-product demand scenario is very important especially when dealing with Reconfigurable Manufacturing Systems that are supposed to cope with flexibility in both functionality and capacity issues.



## 2.9 Design Methodology for Scalable Machining Systems

Spicer (2002b) developed a methodology to design scalable machining systems using an integer linear programming (ILP) based partial enumerative procedure. It attempts to optimize the total life cycle cost of the system configuration including investment cost, operating cost in addition to reconfiguration cost. In evaluating the reconfiguration cost, Spicer (2002b) assumed that all used reconfigurable machine tools (RMTs) have identical machine bases and all the added or removed modules are identical. In addition, this work only considers two main components of reconfiguration cost, namely; labor cost and lost capacity cost.

In this methodology, the following drawbacks can be highlighted; first, the model adopted for throughput is very basic and needs more analytical details, which will require a more powerful optimization tool, e.g. GAs or TS, rather than just the use of ILP in order to be able to handle the complexity of the problem. Second, the work is based on deterministic analysis, which is not sufficient when dealing with dynamic demand expectations. Third, the work is still missing other performance evaluation criteria on the system level that might change the outcome of optimization. Finally, the assumptions made in this work are far from reality where different types of RMTs can be accompanied by different types of modules to be used for different process types such as milling, drilling, turning and boring. In addition there are various cost components to be considered when evaluating the reconfiguration cost such as the investment cost of new equipment, the costs involved in the different activities of buying or selling of machines and/or machine modules, the costs of changing the material handling equipment used in different configurations in addition to the cost of training of workers to use the new equipment being added to the system and many other components. Therefore, in this work, the estimation of the reconfiguration cost is not realistic and difficult to validate. It does not provide accurate insight about the amount of effort required to reconfigure the system because it is based on assumptions that are far from realistic technological facts.

## 2.10 Summary of the Literature Review

A number of research issues and gaps exist regarding the configuration selection for Reconfigurable Manufacturing Systems (RMS) (Youssef and H. ElMaraghy, 2004). The following are some of these issues:

Most of the work done to date either handled the configuration problem from one configuration perspective, namely; physical machine arrangement (Koren *et al.* 1998, Zhong *et al.* 2000, Yang and Hu 2000a, Maier-Sperdelozzi and Hu 2002, Spicer *et al.* 2002a, Maier-Sperdelozzi *et al.* 2003) or dealt with the configuration as a parameter without defining it (Xiaobo *et al.* 2000a, b, 2001a, b, Ohiro *et al.* 2003). Both trends did not consider the automatic generation of feasible alternative configurations for different demand scenarios and considered a narrow pool of feasible configurations in the selection process. The use of a powerful tool such as GAs (Son 2000a, Son *et al.* 2000b, Tang *et al.* 2004) or TS, for generating feasible alternatives and selecting the best is essential to consider other important aspects of the configuration.

A second issue is that most of the work done either focused on only the cost and economic benefits for performance evaluation (Son 2000a, Son *et al.* 2000b, Xiaobo *et al.* 2000a, b, 2001a, b, Ohiro *et al.* 2003) and neglected other system performance evaluation criteria or coupled the cost with the throughput in one objective function (Spicer 2002b, Tang *et al.* 2004) neglecting other criteria.

Another major shortcoming in most of the work done is neglecting the effect of the configuration selection on the smoothness of the subsequent reconfiguration process, which was only tackled by Son (2000a) and Son *et al.* (2000b) but with a very basic configuration similarity model that needs major enhancements, and by Spicer (2002b) but with an unrealistic reconfiguration cost model.

An important drawback of the research work that considered the reconfiguration process as part of the configuration selection process (Son 2000a, Son *et al.* 2000b, Spicer 2002b) was dealing with the problem from a deterministic perspective, which is



not sufficient especially when taking into consideration the anticipated demand and consequently the expected configuration and reconfiguration requirements.

Table 2.1 summarizes the above-mentioned issues for the most relevant research work in the area of configuration selection for RMS and highlights the gaps in this area of research.

Table (2.1) Literature review summary for most relevant research work.

	Aspects of Configuration	Generation of Configurations	System Evaluation Measures	Optimization	Type of Demand	Reconfiguration Smoothness
Xiaobo <i>et al.</i> , 2000a			Cost	Classical	Stochastic	
Xiaobo <i>et al.</i> , 2000b			Cost	Classical	Stochastic	
Xiaobo <i>et al.</i> , 2001a			Cost	Classical	Stochastic	
Xiaobo <i>et al.</i> , 2001b			Cost	Classical	Stochastic	
Ohiro <i>et al.</i> , 2003			Cost	Classical	Stochastic	
Yang and Hu 2000a	Physical arrangement		Throughput	Not considered	Deterministic	
Koren <i>et al.</i> , 1998	Physical arrangement		Multiple	Not considered	Deterministic	
Zhong <i>et al.</i> , 2000	Physical arrangement		Multiple	Not considered	Deterministic	
Maier-S. and Hu 2002	Physical arrangement		Multiple	Not considered	Deterministic	
Spicer 2002a	Physical arrangement		Multiple	Not considered	Deterministic	
Maier-S. <i>et al.</i> , 2003	Physical arrangement		Multiple	Not considered	Deterministic	
Tang <i>et al.</i> , 2004	Multiple	Considered	Cost and throughput	GAs	Deterministic	
Spicer 2002b	Multiple	Considered	Cost and throughput	Classical	Deterministic	Non-realistic cost model
Son 2000a	Multiple	Considered	Cost	GAs	Deterministic	Basic Similarity Metric

In conclusion, there is a need for a configuration selection approach that takes into consideration more than one perspective of the system configuration, involves the production of more than one part type simultaneously and involves stochastic analysis to anticipate the expected configuration requirements. This approach should be capable of

generating a variety of feasible configuration alternatives, which can be accomplished by the use of a meta-heuristic optimization technique such as GAs or Tabu Search. These alternatives can be evaluated by the use of predetermined system evaluation criteria. In the meantime, the smoothness of the anticipated reconfiguration process between any two consecutive configurations should be considered as a part of the configuration selection process. Since, it is difficult to evaluate the exact cost and time of the reconfiguration process, therefore, there is a need for a metric that provides a relative assessment of the cost, effort and time required to reconfigure the system. This metric should consider the different types of activities involved in any reconfiguration process. In addition, the evaluation of the reconfiguration smoothness has to be considered from a stochastic perspective to be able to handle the different future demand expectations. One more important aspect that needs to be incorporated in the selection of RMS configurations is the reconfiguration planning from one configuration to the next.

### 3. RMS CONFIGURATION SELECTION APPROACH

This chapter presents an overview of the general approach, RMS Configuration Selection Approach (Youssef and H. ElMaraghy 2005), that was developed in order to accomplish the objective previously mentioned in Section 1.4 of the dissertation.

#### 3.1 Basic Assumptions

In this section, some of the basic assumptions that will be adopted in the reported research work will be presented.

##### 3.1.1 Configuration Structure

A RMS should be able to provide almost the exact capacity and functionality required to satisfy given demands for a group of products. Therefore, RMSs have characteristics similar to those of dedicated manufacturing systems within a configuration period (CP) because these RMSs should be designed to be dedicated around the products for each CP with exact capacity and functionality. High production volume, in addition to high level of capacity scalability that is one of the main characteristics of RMS, should be considered when deciding upon a RMS's basic structure.

Flow lines, as one form of RMS structures, can satisfy the high production volume requirements. In addition, flow lines can have stages with multiple parallel stations (machines). This facilitates scalability required for RMSs and synchronizes the different stages in order to maximize utilization of the available machines/stations. This will also reduce the effect of breakdown of any of the machines on the overall system performance thus the use of buffers is not always essential (Youssef and H. ElMaraghy 2005, 2006a, c, Youssef *et al.* 2006b). Therefore, the configuration structure of the RMS, used in this work, will be that of a flow line that allows paralleling of identical stations/machines with identical operation assignment in each production stage. Figure 3.1 shows an example of a selected configuration in a specific configuration period (CP) capable of producing two different part types within a part family.

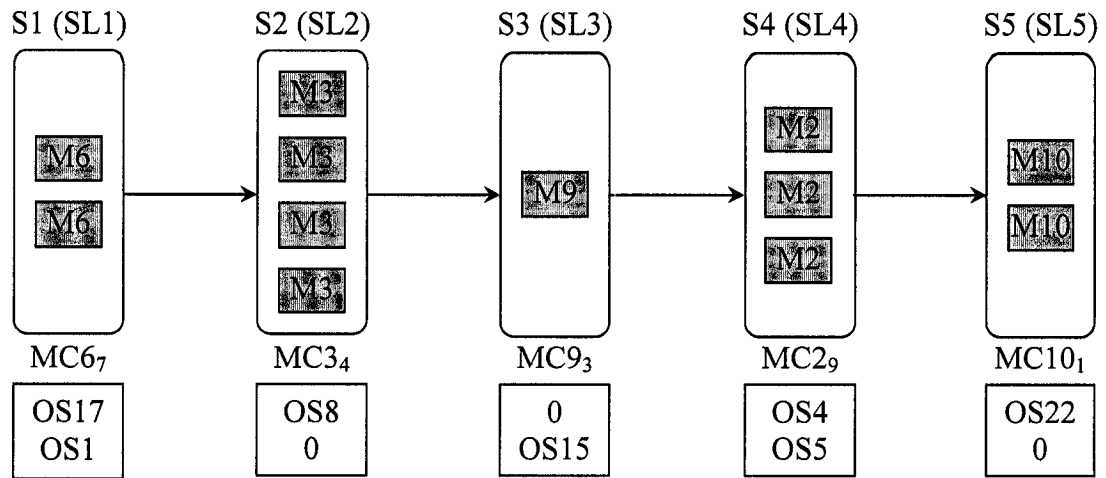

Figure (3.1) An example of a selected configuration for a specific configuration period (CP) (Youssef and H. ElMaraghy 2006c).

Therefore, a selected configuration is a series of stages each containing a group of parallel identical machines/stations. Each stage is represented by information such as stage location (relative to the available space for the flow line), machine/station type (stage type) and its selected machine configuration, number of machines/stations and the assigned operation clusters (operations). In Figure 3.1, S stands for stage, SL stands for stage location, M stands for machine/station,  $MC_{ij}$  stands for machine configuration  $j$  corresponding to machine/station  $i$ , and OS stands for an operation clusters setup. An operation clusters setup (OS) is a set of one or more operation clusters (OCs) that can be performed together on a specific machine with a specific machine configuration. An operation cluster (OC) is a set of operations (OPs) that are always machined together with a specific order due to different types of constraints. These constraints can be logical constraints (L) such as clustering drilling, reaming and possibly boring operations together when producing a hole. They can also be datum tolerance constraints (D), which means that some operations must be carried out on the same machine to preserve the required tolerance accuracy because of having some operations located and carried out with reference to others. A machine configuration (MC) is a feasible configuration for the machine/station capable of performing a specific operation clusters setup (OS). Only one machine configuration (MC) can be assigned to a machine/station in a selected configuration. In Figure 3.1, there are two rows of OSs each representing the OS

assignments to different stages for one of the two part types to be produced and the zeros mean that the stage is not used for that specific part type.

### 3.1.2 Configuration Periods (CPs)

The criteria of configuration selection should include the smoothness of the anticipated reconfiguration process from an existing configuration to the next anticipated configuration. More than one configuration period (CP) are considered. The number of the CPs is function of the availability of anticipated information regarding the demand requirements for each of the following CPs. This information includes the product mix (product types) and the production volume requirements for each product within each CP.

More than one scenario for the anticipated demand requirements should be considered in the demand expectations when dealing with such a dynamic and changing environment. This can only be done through analysis of stochastic nature. Therefore, it is assumed in this work that more than one demand scenario (DS) are possible and the probability of occurrence of each DS in a CP following the current CP is known. The probabilities of occurrence for different DSs that belong to the same CP should sum up to 1. Figure 3.2 presents an example of demand scenarios (DSs) at each configuration period (CP) for the manufacturing of three parts A, B and C over four CPs.

There is only one scenario for the first CP, as can be seen from Figure 3.2, because this CP is the current one, the one of interest, and at the time of selecting its optimal configuration we should be able to know deterministically the demand requirements. On the other hand, for the CPs following the first one, there might be more than one anticipated demand scenario.  $DS_{ij}$  stands for demand scenario number  $j$  in configuration period number  $i$ , whereas  $P_{ij}$  stands for its probability of occurrence. The number in front of each product type represents the production volume requirement of that specific product type within its corresponding demand scenario (DS).

CP1			CP2			CP3			CP4		
<b>DS<sub>11</sub></b>			<b>DS<sub>21</sub></b>			<b>DS<sub>31</sub></b>			<b>DS<sub>41</sub></b>		
P <sub>1</sub> = 1.00			P <sub>21</sub> = 0.60			P <sub>31</sub> = 0.45			P <sub>41</sub> = 0.50		
Product	A	1000	Product	A	1000	Product	A	2000	Product	A	3000
	B	2000		B	3000		B	1500		B	1000
	C	0		C	0		C	1500		C	2000
			<b>DS<sub>22</sub></b>			<b>DS<sub>32</sub></b>			<b>DS<sub>42</sub></b>		
			P <sub>22</sub> = 0.40			P <sub>32</sub> = 0.30			P <sub>42</sub> = 0.50		
Product	A	1500	Product	A	2000	Product	A	2000	Product	A	2000
	B	0		B	0		B	0		B	2500
	C	2500		C	2500		C	2500		C	1500
						<b>DS<sub>33</sub></b>					
						P <sub>33</sub> = 0.25					
Product	A	0	Product	A	0	Product	A	0	Product	A	0
	B	3000		B	3000		B	3000		B	3000
	C	1500		C	1500		C	1500		C	1500

Figure (3.2) Example for demand scenarios (DSs) at different configuration periods (CPs) (Youssef and H. ElMaraghy 2006a).

## 3.2 Input Description

This section provides a brief description of the input parameters and information that are assumed to be available.

### 3.2.1 Demand Scenarios (DSs)

These are the current demand scenario (DS<sub>11</sub>) and the expected DSs for the following configuration periods (CPs) accompanied by their probabilities of occurrence. This should include information regarding the product mix and production volume requirements (Figure 3.2). Such information depends on the market requirements and the goals of the enterprise. The following are the data structures that capture information about the demand scenarios (DSs):



$NCP$	number of configuration periods (CPs) considered
$T[1, \dots, NCP]$	vector representing the duration (in years) of each configuration period where $T(cp)$ is the duration of configuration period $cp$ and $cp$ is the index for configuration periods, $cp = 1, \dots, NCP$
$NDS[1, \dots, NCP]$	vector representing the number of demand scenarios for each configuration period where $NDS(cp)$ is the number of demand scenarios in configuration period $cp$ and $NDS(1) = 1$ (there is only one deterministic DS for the first CP)
$TNP$	total number of part types to be produced in the planning horizon
$DS_{cp, ds}[1, \dots, (TNP+1)]$	vector to give information about demand scenario $ds$ during configuration period $cp \forall ds = 1, \dots, NDS(cp) \forall cp = 1, \dots, NCP$ where $DS_{cp, ds}(p)$ is the demand rate required for part $p$ in demand scenario $ds$ during configuration period $cp$ and $p$ is the index for parts, $p = 1, \dots, TNP$ and $DS_{cp, ds}(TNP+1)$ is the probability of occurrence of demand scenario $ds$ during configuration period $cp$
$RI[1, \dots, NCP]$	vector representing the relative importance for each configuration period in the evaluation of the RS across all CPs which reflects the relevance of the information provided in the DSs for each period where $RI(cp)$ is the relative importance of configuration period $cp$ and $\sum_{cp=1}^{NCP} RI(cp) = 1$

Consider, in the following, one of the demand scenarios  $DS$  with a number of part types to be produced  $NP$  in a configuration period with duration  $T$ .

### 3.2.2 Parts Processing Information (OPs, OCs, OSs and PGs)

OPs are the sets of operations required to produce each of the required parts. OCs are the sets of operations (OPs) to be machined together. These must be accompanied by operations precedence graphs (PGs) that define sequential constraints between the different OPs and subsequently between different OCs. The following are the data structures that capture information about OPs, OCs, OSs and PGs:

### 3.2.2.1 Operations (OPs)

$NOP[1, \dots, NP]$  vector representing the number of operations (OPs) required to produce each part where  $NOP(p)$  is the number of operations required to produce part  $p$  and  $p$  is the index for parts,  $p = 1, \dots, NP$

$OPID_p[1, \dots, NOP(p)]$  vector representing the ID's of the OPs required to produce each part  $p$  where  $OPID_p(x)$  is the ID of  $OP_x$  required to produce part  $p$

$OPP_p[1, \dots, NOP(p)]$  matrix to represent operations precedence relations of part  $p \forall p = 1, \dots, NP$  where

$$OPP_p(x, y) = \begin{cases} 1, & \text{if } OP_x \text{ must be performed before } OP_y \text{ for part } p \\ 2, & \text{if } OP_x \text{ must be performed (clustered) with } OP_y \text{ for part } p \\ 0, & \text{otherwise} \end{cases}$$

where  $x, y$  are the indices for operations,  $x, y = 1, \dots, NOP(p)$

### 3.2.2.2 Operation Clusters (OCs)

$NOC[1, \dots, NP]$  vector representing the number of operation clusters (OCs) required to produce each part where  $NOC(p)$  is the number of operation clusters (OCs) required to produce part  $p$

$OCID_p[1, \dots, NOP(p)]$  vector representing the ID's of the OCs required to produce each part  $p$  where  $OCID_p(i)$  is the ID of  $OC_i$  required to produce part  $p$

$NOPC_p[1, \dots, NOC(p)]$  vector representing the number of OPs in each OC for part  $p \forall p = 1, \dots, NP$  where  $NOPC_p(i)$  is the number of OPs in operation cluster  $i$  for part  $p$  and  $i$  is the index for operation clusters,  $i = 1, \dots, NOC(p)$

$OPC_p[1, \dots, NOC(p)]$  matrix to give information about the OPs of which each OC is composed for part  $p \forall p = 1, \dots, NP$  where

$$OPC_p(i, y) = \begin{cases} 1, & \text{if } OP_y \text{ is a component of } OC_i \text{ for part } p \\ 0, & \text{otherwise} \end{cases}$$

$OCP_p[1, \dots, NOC(p)]$  matrix to represent operation clusters precedence relations of part  $p \forall p = 1, \dots, NP$  where

$$OCP_p(i, j) = \begin{cases} 1, & \text{if } OC_i \text{ must be performed before } OC_j \text{ for part } p \\ 0, & \text{otherwise} \end{cases}$$

where  $i, j$  are the indices for operation clusters,  $i, j = 1, \dots, NOC(p)$



### 3.2.2.3 Operation Clusters Setups (OSs)

- $NOS[1, \dots, NP]$  vector representing the number of operation clusters setups (OSs) for each part where  $NOS(p)$  is the number of possible operation clusters setups (OSs) for part  $p$
- $OSID_p[1, \dots, NOP(p)]$  vector representing the ID's of the OSs for each part  $p$  where  $OSID_p(i)$  is the ID of  $OS_u$  for part  $p$
- $NOCS_p[1, \dots, NOS(p)]$  vector representing the number of OCs in each OS for part  $p \forall p = 1, \dots, NP$  where  $NOCS_p(u)$  is the number of OCs in operation clusters setup  $u$  for part  $p$  and  $u$  is the index for operation clusters setups,  $u = 1, \dots, NOS(p)$
- $OCS_p[1, \dots, NOS(p)]$  matrix to give information about the OCs of which each OS is composed for part  $p \forall p = 1, \dots, NP$  where
- $$OCS_p(u, j) = \begin{cases} 1, & \text{if } OC_j \text{ is a component of } OS_u \text{ for part } p \\ 0, & \text{otherwise} \end{cases}$$
- $OSP_p[1, \dots, NOS(p)]$  matrix to represent operation clusters setups precedence and feasibility of grouping relations of part  $p \forall p = 1, \dots, NP$  where
- $$OSP_p(u, v) = \begin{cases} 1, & \text{if } OS_u \text{ must be performed before } OS_v \text{ for part } p \\ 2, & \text{if } OS_u \text{ cannot be grouped with } OS_v \text{ (common OCs) for part } p \\ 0, & \text{otherwise} \end{cases}$$
- where  $u, v$  are the indices for operation clusters setups,  $u, v = 1, \dots, NOS(p)$

### 3.2.3 Machines/Stations (Ms) Information

This is the set of alternative reconfigurable machine/station types that are available/obtainable for use in the system. These Ms should be associated with the machine configurations (MCs) that can be used with each type and the corresponding cost and steady-state availability information. The following are the data structures that describe machines (Ms) information:

- $NM$  number of available/obtainable reconfigurable machine types
- $NMC[1, \dots, NM]$  vector representing the number of possible machine configurations (MCs) that can be used with each machine type where  $NMC(m)$  is the number of possible machine configurations (MCs) that can be used with machine type  $m$  and  $m$  is the index for machines,  $m = 1, \dots, NM$
- $CMC_m[1, \dots, NMC(m)]$  vector representing the initial cost of all possible MCs for machine  $m \forall m = 1, \dots, NM$  where  $CMC_m(c)$  is the Initial cost of machine configuration  $mc$  for machine  $m$  and  $c$  is the index for

machine configurations,  $c = 1, \dots, NMC(m)$ .  $CMC_m$  includes cost of machine basic structure, modules for axes of motion, spindle modules and fixture modules

$D$  the depreciation rate for the equipment used in the configuration

$I$  annual interest rate

$AMC_m[1, \dots, NMC(m)]$  vector representing the machine steady-state availability of all possible MCs for machine  $m \forall m = 1, \dots, NM$  where  $AMC_m(c)$  is the steady-state availability of machine configuration  $c$  for machine  $m$

### 3.2.4 Machine Configurations (MCs) Information

These are the sets of feasible machine configurations for each machine/station (M) with which it can perform one or more operation clusters (OCs). Only one machine configuration (MC) can be assigned for a machine/station in a selected configuration. These MCs are accompanied by their corresponding feasible OCs and the number of removable modules (axes, spindles, ...etc.) that constitute each of them.  $MC_{ij}$  represents the number of removable modules that constitute machine/station  $i$  in case of having machine configuration  $j$ . In addition, each couple of MCs for the same machine/station (M) should be accompanied by the configuration distance between them in terms of the number of modules that have to be added/removed to/from any of them to obtain the other.  $MC_{ij_2-j_1}$  represents the number of modules added to machine/station  $i$  to change from machine configuration  $j_1$  to machine configuration  $j_2$ .  $MC_{ij_1-j_2}$  represents the number of modules removed from machine/station  $i$  to change from machine configuration  $j_1$  to  $j_2$ . The following are the data structures giving information about machine configurations (MCs):

$NRM_m[1, \dots, NMC(m)]$  vector representing the number of removable modules of all possible MCs for machine  $m \forall m = 1, \dots, NM$  where  $NRM_m(c)$  is the number of removable modules of machine configuration  $c$  for machine  $m$

$DRM_m[1, \dots, NMC(m)]$  matrix to represent the number of modules added and/or removed to/from machine  $m$  to change from one configuration to another  $\forall m = 1, \dots, NM$  where  $DRM_m(c, d)$  is the number of modules added to machine  $m$  to change from configuration  $c$  to configuration  $d$  or number of modules removed from machine  $m$  to change from configuration  $d$  to configuration  $c$  and  $c, d$  are the indices for machine configurations,  $c, d = 1, \dots, NMC(m)$

### 3.2.5 Feasibility and Operation Time for each M-MC-OS Combination

The feasibility and operation time information for a machine/station type (M) with machine configuration (MC) to perform an operation clusters setup (OS), a set of one or more operation clusters (OCs) that can be performed together, should be provided. This enables the estimation of the production rate for this M-MC-OS combination in case it is feasible. The following are the data structures that contain this information:

$FOS_{p,m}[1,\dots,NOS(p)]$  matrix to provide information about the feasibility of producing each possible operation clusters setup for part  $p$  using possible configurations of machine  $m \forall m = 1, \dots, NM \forall p = 1, \dots, NP$  where

$$FOS_{p,m}(u,c) = \begin{cases} 1, & \text{if feasible} \\ 0, & \text{if not feasible} \end{cases}$$

where  $u$  is the index for operation clusters setup,  $u = 1, \dots, NOS(p)$  and  $c$  is the index for machine configurations,  $c = 1, \dots, NMC(m)$

$TOS_{p,m}[1,\dots,NOS(p)]$  matrix to provide the standard time (in seconds) required to produce each possible operation clusters setup for part  $p$  using feasible configurations of machine  $m \forall m = 1, \dots, NM \forall p = 1, \dots, NP$  where

$$TOS_{p,m}(u,c) = \begin{cases} \text{Standard time to produce OS}u \\ \text{using } Mm \text{ with } MCc \text{ for part } p, & \text{if feasible} \\ 0, & \text{if not feasible} \end{cases}$$

$PROS_{p,m}[1,\dots,NOS(p)]$  matrix to provide the production rate (in parts/hr) of producing each possible operation clusters setup for part  $p$  using feasible configurations of machine  $m \forall m = 1, \dots, NM \forall p = 1, \dots, NP$  where

$$PROS_{p,m}(u,c) = \begin{cases} \text{Production rate to produce OS}u \\ \text{using } Mm \text{ with } MCc \text{ for part } p, & \text{if feasible} \\ 0, & \text{if not feasible} \end{cases}$$

### 3.2.6 Space Limitations

The limitations regarding the space allocated for the flow line configuration include the length and width available for the configuration as specified by the system designer. The length can be expressed by the number of available stage locations (NSL), which determines the maximum number of stages. The width can be expressed by the maximum number of parallel machines/stations within a stage. The following are the data structures that provide information about space limitations:

*NSL* number of available stage locations (maximum number of stages)  
*MMS* maximum number of parallel machines per stage

### 3.2.7 Investment Limitation

The initial investment in the configuration is defined by the higher-level management according to the budgetary constraints. This includes cost of machines, axes, spindles and fixtures. The following is the data structure giving information about investment limitation:

*MI* maximum allowable initial investment in the configuration  
(machines, axes, spindles and fixtures)

### 3.2.8 The Configuration (C0) of CP0

This provides the full information that describes the configuration (C0) that was utilized in period CP0, the period prior to the period of interest (CP1). The following are the data structures that provide this information:

$NS_0, M_0[1 \dots NS_0], MC_0[1 \dots NS_0], NMS_0[1 \dots NS_0], OS_{p,0}[1 \dots NS_0] \forall p = 1, \dots, NP,$   
 $SL_0[1 \dots NS_0]$

The detailed definitions of these data structures are similar to those of the output data structures that are described in the following section.

### 3.3 Output Description

The output of the RMS Configuration Selection Approach is a group of sets of selected configurations. Each one of these sets consists of the selected configurations corresponding to all possible DSs over the system planning horizon including the configuration C1 selected for the current configuration period (CP1), the period of interest. Each of the selected configurations produced, as mentioned in Section 3.1.1, is a series of stages, each of which contains information such as stage location (relative to the available space for the flow line), machine/station type (stage type) and its selected machine configuration, number of machines/stations and the assigned operation clusters setups (Figure 3.1). The configurations, C1s, corresponding to the current configuration period (CP1), the period of interest, are accompanied by the detailed execution plan of reconfiguration from the previous configuration (C0) to these configurations. The following are the data structures that provide information about a selected multiple-aspect configuration corresponding to any of the DSs:

- $NS$  number of stages
- $M[1, \dots, NS]$  vector representing the machine type allocated to each stage where  $M(s)$  is the machine type allocated to stage  $s$  and  $s$  is the index for stages,  $s = 1, \dots, NS$
- $MC[1, \dots, NS]$  vector representing the machine configuration selected for the machine type in each stage where  $MC(s)$  is the machine configuration selected for machine type  $M(s)$  in stage  $s$
- $NMS[1, \dots, NS]$  vector representing the number of identical parallel machines in each stage where  $NMS(s)$  is the number of identical parallel machines of type  $M(s)$  in stage  $s$
- $OS_p[1, \dots, NS]$  vector representing the operation clusters setup assigned to the machines in each stage for part  $p \forall p = 1, \dots, NP$  where
 
$$OS_p(s) = \begin{cases} \text{OS assigned to machines in stage } s, & \text{if stage } s \text{ is used for part } p \\ 0, & \text{if stage } s \text{ is not used for part } p \end{cases}$$
- $SL[1, \dots, NS]$  vector representing the location of each stage where  $SL(s)$  is the location of stage  $s$

Figure 3.3 represents an IDEF0 model for the RMS Configuration Selection Approach summarizing the inputs, outputs, mechanisms and control parameters.

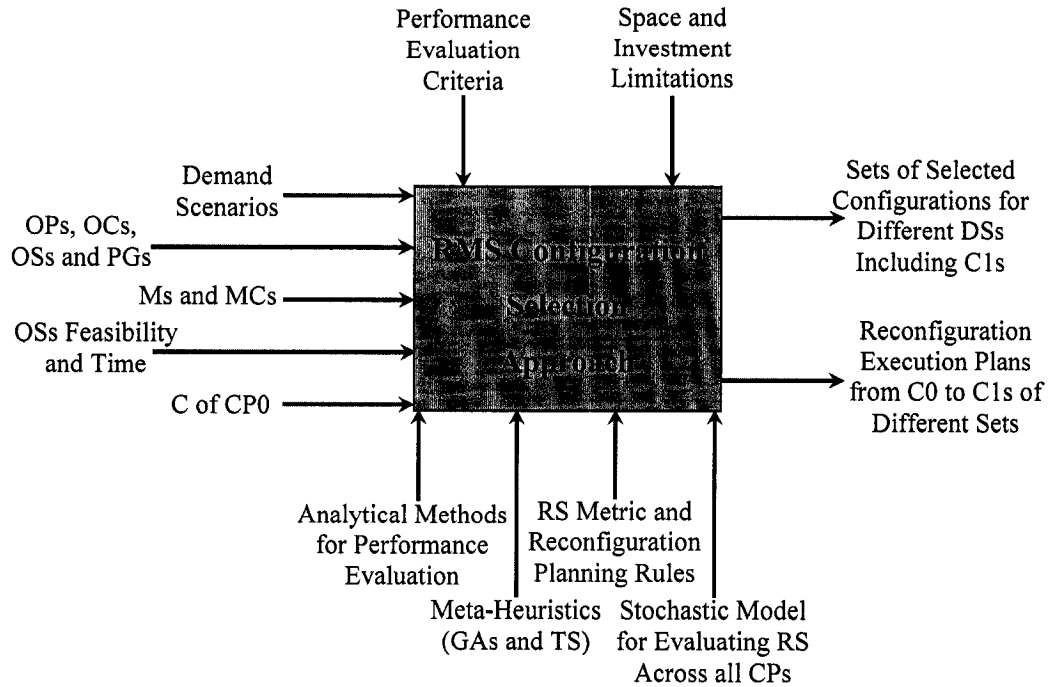

Figure (3.3) IDEF0 model for the RMS Configuration Selection Approach.

### 3.4 RMS Configuration Selection Procedure

This section presents a brief description of the overall procedure performed by the developed RMS Configuration Selection Approach in order to accomplish the target research objective. This procedure is further detailed in the following chapters of the dissertations. The procedure has two main stages.

#### 3.4.1 The First Stage

This stage deals with the selection of near-optimal alternative configurations for each individual demand scenario (DS) across all configuration periods (CPs) considered (See Figure 3.2 as example of different DSs at each CP). This is an optimization process, which is governed by given system evaluation criteria (capital cost of configuration and system availability) regardless of the anticipated reconfiguration smoothness between consecutive configurations.

Meta-heuristics, GAs and TS, are utilized for the generation and selection of near-optimal group of configurations for each DS according to the chosen system evaluation

criteria and the given constraints. A constraint satisfaction procedure is implemented through mapping from the discrete domain of variables to a continuous domain that guarantees the feasibility of all the generated configurations. This helps in the automatic generation of feasible configuration alternatives using the meta-heuristics which is followed by performance evaluation of these configurations.

The output of this stage is a predefined number of alternative configurations for each DS at each CP (See Figure 3.1 as an example of a fully defined configuration). These selected configurations will be near-optimal configurations according to the optimization performed by the meta-heuristic (GAs and TS). The number of these selected configuration alternatives (NC) will be the minimum of two values; a predefined number (default is 10) or the number of configurations within a specific predefined tolerance limit, regarding their evaluation, compared to the best of these configurations (default is 5%). Figure 3.4 illustrates an example of the output of the first stage for one of the considered DSs. In that figure,  $C_{ijk}$  represents alternative configuration number  $k$  for demand scenario  $DS_{ij}$  whereas  $NC_{ij}$  represents the number of alternative configurations for the same demand scenario.

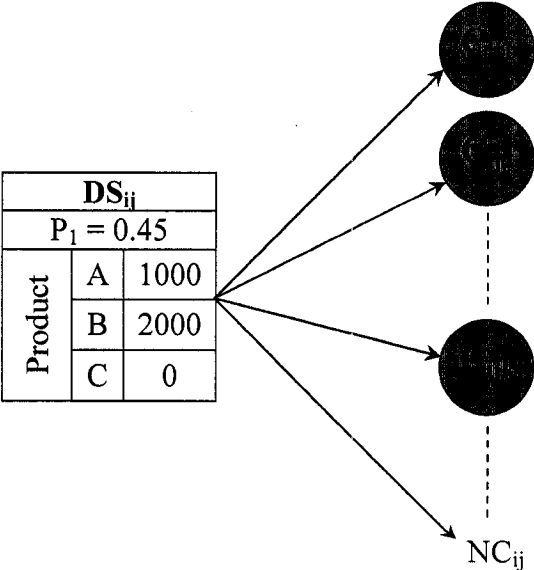

Figure (3.4) Configuration alternatives for a demand scenario (DS<sub>ij</sub>).

The main reason for having more than one alternative for each DS is to provide the second stage of the procedure with a variety of good alternatives to choose from in order



to achieve near-optimal level of reconfiguration smoothness, which is the main objective of the second stage of the procedure.

### **3.4.2 The Second Stage**

This stage deals with determining which of the alternatives produced in the first stage for the demand scenario (DS) of the first configuration period (CP) (the period of interest) optimizes the degree of reconfiguration smoothness across all the configuration periods and the corresponding preliminary selected configurations for each of the possible DSs in the following CPs. This is accompanied by the execution plans to reconfigure the system from C0 to C1 of each set of configurations.

This stage is based on a reconfiguration smoothness (RS) metric and a set reconfiguration planning rules. The RS metric gives a relative measure of the effort, time and cost of reconfiguring the system from one configuration to the next. The reconfiguration planning rules help in determining the exact location of the different production stages in the system and thus in developing execution plans for reconfiguring the system from one configuration to the next in a way that minimizes the reconfiguration effort. A stochastic model utilizes these RS evaluations to determine the reconfiguration smoothness across (RSA) corresponding to any candidate set of configurations corresponding to all the DSs at different CPs. This model is based on the probability of occurrence of each DS within its CP in addition to the predetermined relative importance of each CP in the RSA evaluation. Meta-heuristics (GAs and TS) are utilized to generate and select near-optimal sets of configurations based on this stochastic model for performance evaluation of different alternatives.

The stage starts with determining an upper bound for the RSA which is called reconfiguration smoothness limit (RSL). The RSL is the RSA corresponding to the set of configurations composed of the best near-optimal configurations corresponding to the different DSs at different CPs (the best configuration for each DS among those generated from the first stage). This RSL is then used to constrain the optimization process as it is not recommended to select a set of configurations with RSA inferior to that of the set of



best configurations in addition to being inferior in terms of the criteria used in the first stage (cost and availability).

The next step in this stage is to perform discrete optimization using GAs and TS to generate and select a number of near-optimal sets of configurations according to the RSA evaluation without violating the RSL. In this optimization process, the different demand scenarios (DSs) are treated as variables for which the domains of values are the alternative configurations provided from the first step for each DS.

The output of this stage is a number of candidate configurations for the current (first) CP (the period of interest). Each of these candidate configurations will be accompanied by a preliminary selection of a combination of configurations across all CPs that optimizes the RSA evaluation. The number of these selected sets of configurations (NSC) will be the minimum of two values; a predefined number (default is 10) or the number of configuration sets within a specific predefined tolerance limit, regarding their evaluation, compared to the best set (default is 5%). In addition, and for each of these sets, the execution plans for reconfiguring the system from C0 to C1 of that set is developed according to the reconfiguration planning rules. Figure 3.5 presents an example of a selected set of configurations for a system with only two CPs in its planning horizon.

The generated sets of configurations not only have near-optimal RSA evaluation but are guaranteed to be within a very small tolerance from the near-optimal configurations according to the predetermined system evaluation criteria used in the first stage. Figure 3.6 summarizes the overall procedure.

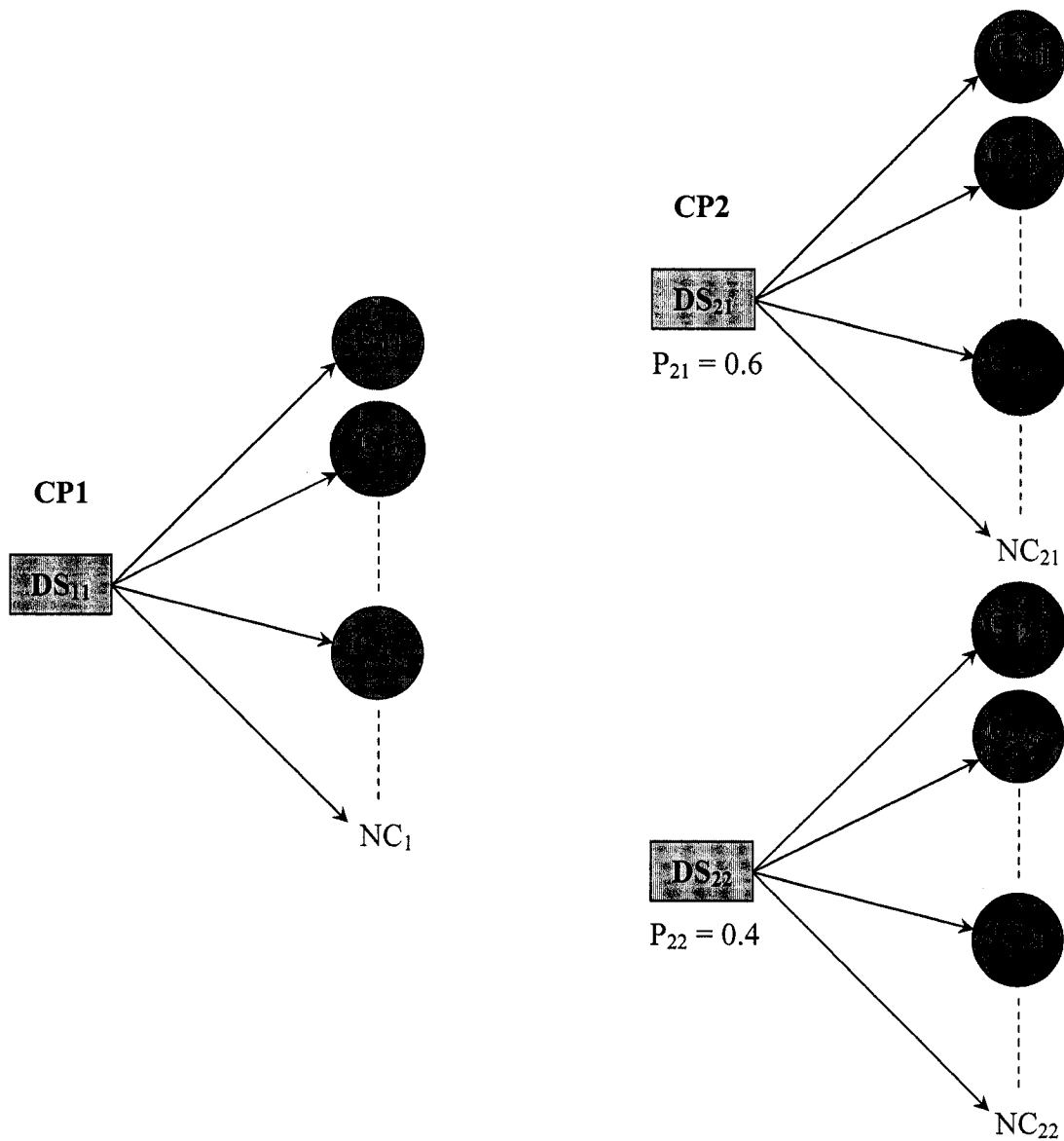

Figure (3.5) A selected set of configurations for a system with only two CPs.

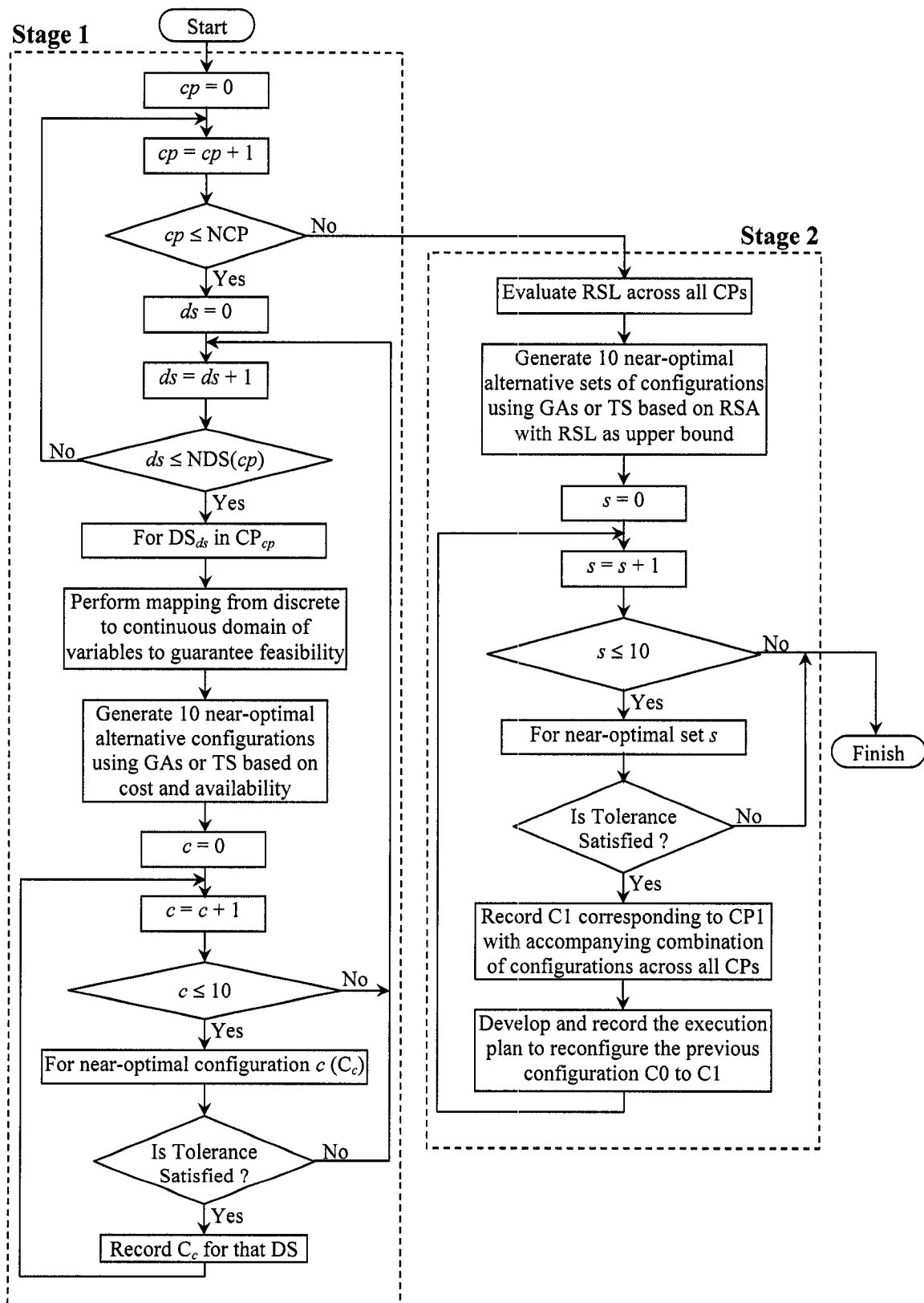

Figure (3.6) The overall RMS configuration selection procedure.

## 4. MODELING AND OPTIMIZATION OF MULTIPLE-ASPECT RMS CONFIGURATIONS

This chapter provides a model for optimizing capital cost of multiple-aspect RMS configurations without considering machine availability based on the work done by Youssef and H. ElMaraghy (2006c). The optimized configurations can handle multiple-parts and their structure is that of a flow line allowing paralleling of identical machines in each production stage as defined in Section 3.1.1 and exemplified in Figure 3.1. The various aspects of the RMS configurations being considered include arrangement of machines (number of stages and number of parallel machines per stage), equipment selection (machine type and corresponding machine configuration for each stage) and assignment of operations (operation clusters assigned to each stage corresponding to each part type). The mathematical model and a novel constraint satisfaction procedure are presented and the use of GAs and M-C-RTS to solve the optimization problem is described. A toolbox was developed using MATLAB software to demonstrate the use of the developed optimization model, which is verified using a case study based on an example part from the literature. The results of both optimization techniques are presented, analyzed and compared for validation.

### 4.1 Mathematical Model

This section presents the optimization mathematical model based on the parameters and data structures defined in Section 3.2 for input and in Section 3.3 for output.

#### 4.1.1 Assumptions

The following assumptions are made:

1. The set-up time to change from one part type to another is negligible.
2. The steady-state availability of the different M-MC combinations is 100% (i.e. machine downtime is not considered).

## 4.1.2 Decision Variables

Number of stages	$NS$
Machine types	$M = \{m_1, m_2, \dots, m_{NS}\}$ , where $m_s$ represents the machine type allocated to stage $s$
Machine configurations	$MC = \{c_1, c_2, \dots, c_{NS}\}$ , where $c_s$ represents the configuration selected for machine $m_s$ in stage $s$
Numbers of parallel machines	$NMS = \{n_1, n_2, \dots, n_{NS}\}$ , where $n_s$ represents the number of identical parallel machines of type $m_s$ used in stage $s$
Operation clusters setups	$OS_p = \{o_{p,1}, o_{p,2}, \dots, o_{p,NS}\} \forall p = 1, 2, \dots, NP$ , where $OS_{p,s}$ represents the operation clusters setup assignment of machine type $m_s$ used in stage $s$ to produce part $p$ and $NP$ is the number of parts to be produced.

## 4.1.3 Objective Function and Constraints

Minimize the capital cost of configuration in the present value. The following equation is adapted from (Fraser *et al.* 2006):

$$\text{Min. } CC(NS, M, MC, NMS) = \sum_{s=1}^{NS} \left( n_s \times CMC_{m_s}(c_s) \times \left[ 1 - \left( (1-D)^T \times (P/F, I, T) \right) \right] \right), \quad (4.1)$$

where  $CC$  is the capital cost of configuration and

$$(P/F, I, T) = \frac{1}{(1+I)^T}$$

is the present worth factor (Fraser *et al.* 2006).

Subject to

### 4.1.3.1 Space Constraints

- *Number of stages* (configuration length). The number of stages cannot exceed the number of available stage locations

$$NS \leq NSL. \quad (4.2)$$

- *Number of parallel machines* (configuration width). The number of identical parallel machines in any stage cannot exceed the maximum number of parallel machines per stage

$$n_s \leq MMS \quad \forall s = 1, 2, \dots, NS. \quad (4.3)$$

#### 4.1.3.2 Precedence and Overlap Constraints

- All operation clusters setups assigned to different configuration stages satisfy the precedence constraints and do not include overlapping operation clusters

$$OSP_p(o_{p,s_1}, o_{p,s_2}) = 0 \quad \forall s_1 > s_2 \quad \forall p = 1, 2, \dots, NP, \quad (4.4)$$

where  $s_1, s_2 \in S_p$  and  $S_p$  is the set of stages used for producing part  $p$ , which means that  $o_{p,s_1}, o_{p,s_2} > 0$ .

#### 4.1.3.3 Functionality Constraints

- Machine configurations capabilities.* All operation clusters setups used for producing different parts must be assigned to machine configurations capable of performing them

$$FOS_{p,m_s}(o_{p,s}, c_s) = 1 \quad \forall s \in S_p \quad \forall p = 1, 2, \dots, NP, \quad (4.5)$$

where  $S_p$  is the set of stages used for producing part  $p$ , which means that  $o_{p,s} > 0$ .

- Operation clusters setup assignments.* The operation clusters setups assigned to produce each part contain exactly the operation clusters required to produce that part

$$\sum_{s \in S_p} NOCS_p(o_{p,s}) = NOC(p) \quad \forall p = 1, 2, \dots, NP, \quad (4.6)$$

where  $S_p$  is the set of stages used for producing part  $p$ , which means that  $o_{p,s} > 0$ .

- Usage of stages.* Each stage in the configuration is used in producing at least one of the parts

$$\sum_{p=1}^{NP} o_{p,s} > 0 \quad \forall s = 1, 2, \dots, NS. \quad (4.7)$$

#### 4.1.3.4 Capacity Constraint

- The configuration has sufficient capacity to satisfy the required demand rate for all parts. The following equation is adapted from (Nahmias 2001):

$$\sum_{p=1}^{NP} \frac{DS(p)}{n_s \times PROS_{p,m_s}(o_{p,s}, c_s)} \leq 1 \quad \forall s = 1, 2, \dots, NS. \quad (4.8)$$

#### 4.1.3.5 Investment Constraint

- The total initial investment in the configuration cannot exceed the maximum allowable value

$$\sum_{s=1}^{NS} (n_s \times CMC_{m_s}(c_s)) \leq MI \quad (4.9)$$

#### 4.1.3.6 Decision Variable Domain Constraints

- *Number of stages*

$$NS \in \{1, 2, \dots, NSL\}. \quad (4.10)$$

- *Machine Types*

$$m_s \in \{1, 2, \dots, NM\} \quad \forall s = 1, 2, \dots, NS. \quad (4.11)$$

- *Machine configurations*

$$c_s \in \{1, 2, \dots, NMC(m_s)\} \quad \forall s = 1, 2, \dots, NS. \quad (4.12)$$

- *Number of parallel machines*

$$n_s \in \{1, 2, \dots, MMS\} \quad \forall s = 1, 2, \dots, NS. \quad (4.13)$$

- *Operation clusters setups*

$$o_{p,s} \in \{0, 1, 2, \dots, NOS(p)\} \quad \forall s = 1, 2, \dots, NS \quad \forall p = 1, 2, \dots, NP. \quad (4.14)$$

## 4.2 String Representation

A string representation for the anticipated the multiple-aspect configuration (solution) was developed to provide full information about the solution in a compact format. The string (Figure 4.1) is composed of a number of elements starting with the number of stages ( $NS$ ) followed by groups of elements each of which represents the different parameters of each stage. The number of elements in each of these groups is  $(3+NP)$ . The length of the string is function of the number of stages. Therefore, different solutions might lead to solution strings of different lengths. This form of representation is concise and easy to comprehend yet informative as it gives all the details required to completely describe the multiple-aspect configuration in addition to being reflective of the configuration length.

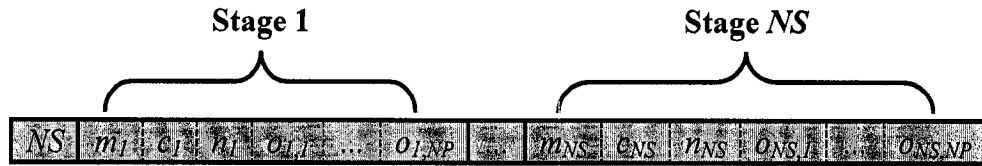

Figure (4.1) String representation of the anticipated solution (the multiple-aspect configuration) (Youssef and H. ELMaraghy 2006c).

### 4.3 Constraint Satisfaction Procedure

The optimization problem, as described and modeled earlier in this chapter, is rather a complicated problem in terms of constraint satisfaction. This section provides a description of a novel procedure that was developed to overcome this challenge and help in supporting the automatic generation of feasible alternative multiple-aspect configurations (i.e. solutions).

The procedure is based on transforming the original search space into a new search space composed of a set of variables with varying domain sizes. The domains of these new variables are generated individually in a way that guarantees the satisfaction of almost all the specified constraints. The new set of variables consists of three groups. The domain of each variable in the first group represents the feasible alternative permutations of operation clusters setups (OSs) for each of the parts to be produced by the system. These permutations are associated with their feasible locations within the boundaries of the system, which represent the domains of the second group of variables. The different feasible alternative machine configurations for producing all the possible combinations of OSs from different parts simultaneously in the same stage while satisfying the demand rate requirements are generated, as well, and become a basis for constructing the domains of the third group of variables.

The new generated search space requires the use of another domain of variables to accommodate the varying domain sizes of the discrete variables described above. A continuous domain of variables permits dealing with domains of varying sizes without losing the merits of having equal probabilities of occurrence for the different alternatives. The following sections present a brief description of the main stages of the developed procedure.



### **4.3.1 Generation of Feasible OS Permutations (Sequences) for All Parts**

This stage is concerned with generating all the feasible OS permutations (sequences) that cover all the operation clusters (OCs) required to produce each of the considered parts without repetitions of OCs, violations of the precedence constraints or exceeding the allowed number of production stages (maximum configuration length). Therefore, this stage guarantees that the generated permutations satisfy the precedence and overlap constraints [Eq. (4.4)], the OSs assignments constraints [Eq. (4.6)] and the OSs domain constraints [Eq. (4.14)] and partially satisfy the configuration length constraint [Eq. (4.2)] (each part needs a number of stages within the acceptable limits). This procedure is performed for each part considered and is composed of the following steps:

1. Determine the OSs that contain only single OCs which are not part of any other OS, if there is any, as they have to be part of any combination.
2. Determine the remaining OSs and the remaining OCs required to produce the part.
3. Generate all possible combinations of the remaining OSs that contain exactly all the remaining OCs without overlapping or exceeding the allowable configuration length when added to the OSs determined in Step 1.
4. Add each combination generated in Step 3 to the OSs determined in Step 1.
5. Store all the generated feasible OS combinations and their total number.
6. Generate all possible permutations (sequences), for each of the combinations stored in Step 5, that do not violate the precedence constraints. This step is recursive and is adapted from the partial precedence graph sorting technique (Gen and Cheng 2000).
7. Store all the generated permutations corresponding to each combination and their total number.

### **4.3.2 Generation of Possible Stage Locations for OS Permutations**

This stage of the procedure is concerned with generating all the possible sets of stage locations for different OS permutations for all parts being considered within the allowable limit of configuration length (maximum number of stages in the configuration). A set of stage locations means the distribution of the OSs that belong to a permutation

alternative over the available stage locations of the system. This generated set of stage locations is function of the number of OSs in the permutation and the maximum allowable number of stages. The number of possible sets for each case (for each number of OSs in a permutation) is stored. Therefore, this stage guarantees that the generated possible allocations of OSs to stage locations satisfy the configuration length constraint [Eq. (4.2)] for all parts and the number of stages domain constraint [Eq. (4.10)].

### **4.3.3 Generation of Feasible M-MC Alternatives for All OS**

#### **Combinations**

This stage of the procedure is concerned with generating all the M-MC alternatives (from the available/obtainable list) that are capable of satisfying the demand rate requirements for every possible combination of OSs for all the parts considered when being produced simultaneously by the same stage. The minimum number of parallel machines required to satisfy the demand requirements accompanies the generated feasible alternatives. This number has to be less than or equal to the configuration width (maximum number of machines in parallel) in order for the alternative to be feasible. Therefore, this stage guarantees that the generated M-MC alternatives for each combination of OSs satisfy the configuration width constraint [Eq. (4.3)], the machine configurations capabilities constraints [Eq. (4.5)], the capacity constraints [Eq. (4.8)], the machine types domain constraints [Eq. (4.11)], the machine configurations domain constraints [Eq. (4.12)] and the number of parallel machines domain constraints [Eq. (4.13)]. This stage is composed of the following steps:

1. Generate all the possible combinations of OSs from all parts that can be simultaneously performed at the same stage including the option of not using the stage for one or more of the parts but it should at least be used by one of the parts.
2. Generate all the M-MC combinations that are capable of producing each possible set of OSs generated in Step 1.
3. Determine the minimum number of parallel machines for each M-MC combination generated in Step 2 required to satisfy the demand requirements of all parts in that stage. If the number is acceptable (less than or equal to the

maximum configuration width) then store M-MC alternative accompanied with the minimum number of machines corresponding to the OS combination.

4. Store the total number of M-MC alternatives generated in Step 3 corresponding to each OS combination.

#### **4.3.4 Mapping of Domains and Encoding of Variables**

A new set of variables is required to represent the solution of the problem in terms of the selected alternatives from those generated by the procedures described in Sections 4.3.1-4.3.3. The numbers of generated feasible alternatives in each of the previous stages vary according to the part type and depend on the selection made in other stages. The domain sizes of the alternatives, to select from, vary accordingly. The use of continuous domain variables solves this problem as it permits dealing with varying domain sizes while maintaining equal probabilities of selecting each alternative. In addition, this facilitates the manipulation of the generated solutions in terms of crossovers and mutations for the purpose of producing better solutions without affecting the feasibility of the generated solutions.

The multiple-aspect configuration (solution), expressed by the new domain of variables, is encoded by a string composed of three portions corresponding to: (1) Sequence of OSs for each part, (2) Distribution of OS sequences over the different available production stage locations and (3) M-MC selections corresponding to each stage. All variables in this string are continuous variables ranging between 0 and 1. The number of variables in each of the first two groups is equal to the number of parts,  $NP$ , while in the third group; it is equal to the number of available stage locations,  $NSL$ . Figure 4.2 depicts the string that encodes the multiple-aspect configuration represented in the new domain of variables to be used in the GAs optimization process.

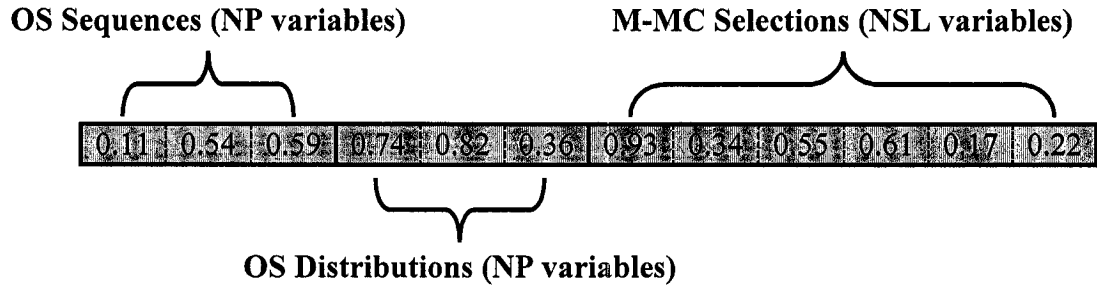

Figure (4.2) String representation of the encoded multiple-aspect configuration (Youssef and H. ElMaraghy 2006c).

The string representation of the new set of variables highlights three important advantages of the new search space compared to the original one other than the fact that it guarantees the satisfaction of most of the specified constraints:

1. The number of control variables is drastically reduced from  $[1+(3+NP)*NS]$  as shown in Figure 4.1 to  $[(2*NP)+NSL]$  as shown in Figure 4.2. This means a reduction from 51 variables to 14 variables for the case of 2 part types and 10 stage locations, and a reduction from 91 variables to 21 variables for 3 parts and 15 stage locations and so on. This is a significant advantage in solving optimization problems.
2. The number of control variables is no longer function of the number of stages,  $NS$ , which is one of the control parameters. Therefore, for a specific number of part types (demand characteristic) and number of stage locations (system characteristic), all the generated solutions in the new solution space have equal size (equal number of variables), which facilitates the manipulation of these variables.
3. The size of the search space is reduced from an order that is exponential in  $(NP*NS)$  to an order that is exponential in  $((2*NP)+NSL)$ .

#### 4.3.5 Decoding of Variables

Decoding is the translation of any of the produced encoded solution strings (Figure 4.2) to a multiple-aspect configuration as depicted by the solution string in Figure 4.1. The encoded string has three groups of variables as described earlier that can be decoded by the following procedure:

#### **4.3.5.1 Decoding the OS Sequences**

Each variable in the first portion of the string determines the selected feasible sequence of OSs for one of the part types from those generated in the first stage of this procedure (as described in Section 4.3.1). The value of the continuous domain variable that ranges from 0 to 1 is multiplied by the total number of OS combinations generated in Step 5 of the stage and then rounded up to the nearest integer which will in turn represent the order of the selected combinations in those stored in the same step. The incremental difference between the original value of the variable and the rounded-up value determines, in the same manner, the selected permutation (sequence) of OSs for the selected combination from those generated and stored in Step 7. This warrants equal probability of selection for all the possible feasible combinations and within each combination equal probability of selection for all possible permutations (sequences). Therefore, a feasible sequence of OSs is determined for each part type.

#### **4.3.5.2 Decoding the OS Distributions**

The second portion of the string determines, for each part type, the distribution of the OS sequences determined by the first portion over the available stage locations of the system. Each variable is multiplied by the total number of possible sets of stage locations as determined in the second stage of this procedure. The output value is rounded up to the nearest integer that represents the order of the selected set of stage locations in those stored in the same stage. Thus, the sequence of OSs for each part type is, now, assigned to a production stage. Each production stage, accordingly, will either be used by one part, more than one part or not used by any of the parts (redundant stage). Redundant stages are eliminated from the solution string, which guarantees the satisfaction of the usage of stages constraints [Eq. (4.7)]. Therefore, the number of production stages is now determined.

#### **4.3.5.3 Decoding the M-MC Selections**

Each variable in the third group of variables in the solution string determines the M-MC selection corresponding to each of the production stages of the system after identifying its usage by the different part types, which is determined by the second group of variables. The value of the variable is multiplied by the total number of M-MC feasible

alternatives corresponding to the OS combination assigned to that stage as determined in Step 4 of the third stage of this procedure (Section 4.3.3). The output value is rounded up to the nearest integer that represents the order of the selected M-MC alternative from those stored in Step 3 of the same stage. A feasible M-MC assignment is determined, accordingly, for each production stage of the system.

#### **4.3.5.4 Repair Procedure**

A repair procedure is followed if there is no M-MC feasible alternative available for the OS combination assigned to any of the production stages. One of the variables of the first two portions of the solution string is chosen and regenerated randomly and the whole decoding scheme is repeated until M-MC feasible alternatives are assigned to all production stages.

#### **4.3.6 Penalty Function**

The only constraint that is not satisfied by the procedure so far is the investment constraint [Eq. (4.9)]. A penalty function is used to ensure that the search tries to satisfy this constraint. If the total initial investment exceeds the maximum allowable value  $MI$ , a penalty value of  $MI$  multiplied by the exceeded value is added to the objective function value.

### **4.4 Optimization Using Genetic Algorithms**

A special case of this optimization problem with fixed machine configurations, fixed order of operations and no consideration of capacity requirements was proven to be NP-hard (Kimms 2000). Thus, the multiple-aspect configuration selection problem, as defined in its original search space, must also be NP-hard. In spite of the reduction in the size of the search space according to the proposed constraint satisfaction procedure, the new search space is still exponential in the size of the problem as shown in Section 4.3.4. In addition, the problem is multi-modal in terms of the new domain of variables. Genetic Algorithms (GAs) (Holland 1975) have been broadly used as a powerful meta-heuristic global (hill-climbing) optimization method that can solve such problems, which are difficult to solve using traditional optimization techniques except by resorting to approximation.

Traditional GAs code the independent variables into binary strings known as chromosomes, which discretizes the continuous domain variables. Coarse discretization limits the search resolution and might lead to near-to-global optimal solutions. On the other hand, fine discretization leads to long binary chromosomes and hence would increase the search space. Such increase may be drastic leading to prohibiting large search spaces (Michalewicz *et al.* 1994). Currently, research in Genetic Algorithms tends to use real-coded representations for continuous parameter optimization problems (Hererra *et al.* 1998). Such version of GAs is known as real-coded GAs and has some advantages. First, real parameters make it possible to use large domains for the independent variables. Second, real parameters tend to exploit the gradual changes in the objective function corresponding to gradual changes in the independent variables. The above reasons led to the choice of real-coded GAs to seek the near global optimal multiple-aspect configurations.

Appendix A gives a general overview of GAs and a brief description of the operators used for the real-coded GAs. Table 4.1 provides the population size, the number of generations and the number of times each operator is applied in the optimization of the multiple-aspect configuration. These parameters are suitable for the size of the problem and proved to be appropriate as shown later in the results.

Table (4.1) Parameters used in real-coded GAs.

<b>Parameter</b>	<b>Value</b>
Population size	100
Number of generations	150
Number of times of cross-over application (arithmetic cross-over, simple cross-over and heuristic cross-over)	Four times for each operator
Number of times of mutation application (uniform mutation, boundary mutation, non-uniform mutation and whole non-uniform mutation)	Eight times for each operator



## 4.5 Case Study

### 4.5.1 Example Part

In order to verify the presented optimization model and demonstrate the use of the developed toolbox, based on that model, a case study is presented using an example part (CAM-I\*, 1986 test part ANC-101) and its data that are widely used in the literature (Li *et al.* 2002, Ong *et al.* 2002, Kiritsis and Porchet 1996, Henderson *et al.* 1994, Gupta *et al.* 1994 and Hummel and Brown 1989). Figure 4.3 shows part ANC-101 and its features.

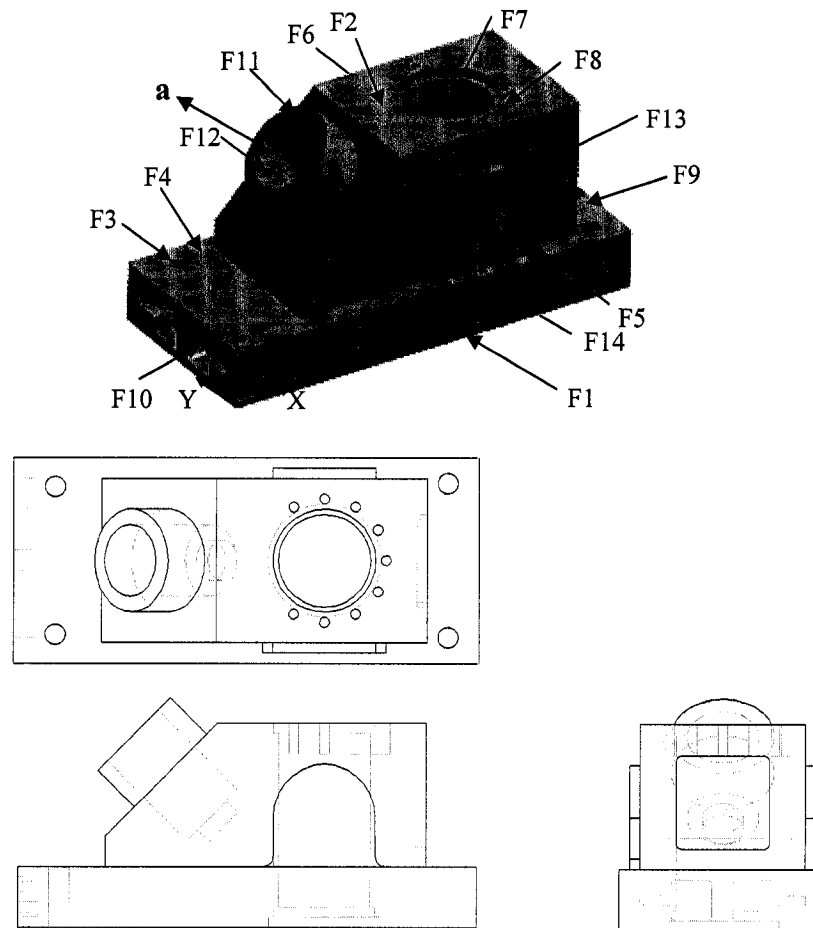

Figure (4.3) Part ANC-101 and its features.

A basic part (ANC-90) was developed as a variant of part ANC-101. This part is similar to part ANC-101 but with five fewer features. Figure 4.4 shows part ANC-90 and its features.

\*CAM-I: Computer Aided Manufacturing - International

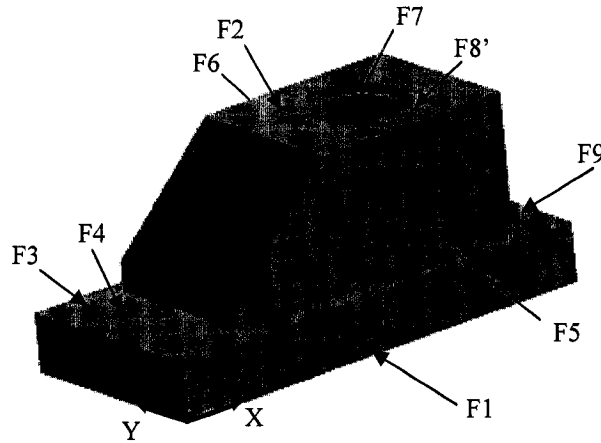

Figure (4.4) Part ANC-90 and its features.

Appendix B provides all the machine processing information for the two parts. Tables B.1 and B.2 provide the operations data for both parts. Figure B.1 shows the OPs precedence graph for part ANC-101 while Figure B.2 demonstrates the precedence relationship between the OCs that are listed in Table B.3. Figure B.3 shows the OPs precedence graph of part ANC-90 while Figure B.4 represents the precedence graph for the OCs that are listed in Table B.4. Table B.5 provides a listing of the available/obtainable resources in terms of reconfigurable machines (Ms), their feasible machine configurations (MCs) accompanied by the initial cost and the number of removable modules for each M-MC combination. The depreciation rate for these machines is assumed to be 10%. Table B.6 provides the time required for performing different OSs using different feasible M-MC combinations and the production rates information accordingly. Note that the production rate for the machines with multi-spindle configurations is a multiple of that for the same machine with a single-spindle configuration although they have the same standard time.

#### 4.5.2 Case Description

Now, all the processing information for both parts (ANC-90 and ANC-101), the information about the available/obtainable resources, and the production rates of using these resources to produce the different operation clusters setups for the two parts are well defined.

Consider the case of having a configuration period (CP) with a duration of 1.5 years where part ANC-90 (part A) is to be produced with a rate of 120 parts/hour and part ANC-101 (part B) is to be produced with a rate of 180 parts/hour simultaneously. The annual interest rate is assumed to be 12%. Variation in this rate does not affect the selected configuration (the end result) as it will have a relatively similar effect on the capital costs of all the candidate configurations. The system designer specified the maximum number of stages to be 10 and the maximum number of parallel machines per stage to be 5. The maximum allowable budget for initial investment is 30 million US Dollars.

### 4.5.3 Results and Discussion

The optimal capital cost of the manufacturing system configuration that satisfies the demand requirements of the case study is 4.174 million US Dollars. This value was obtained consistently through most of the runs performed using the developed toolbox which supports the selection of the GA parameters provided in Table 4.1 that were used in all the runs. Figure 4.5 demonstrates a sample of the GA convergence curves that reached this same value as obtained in various other runs.

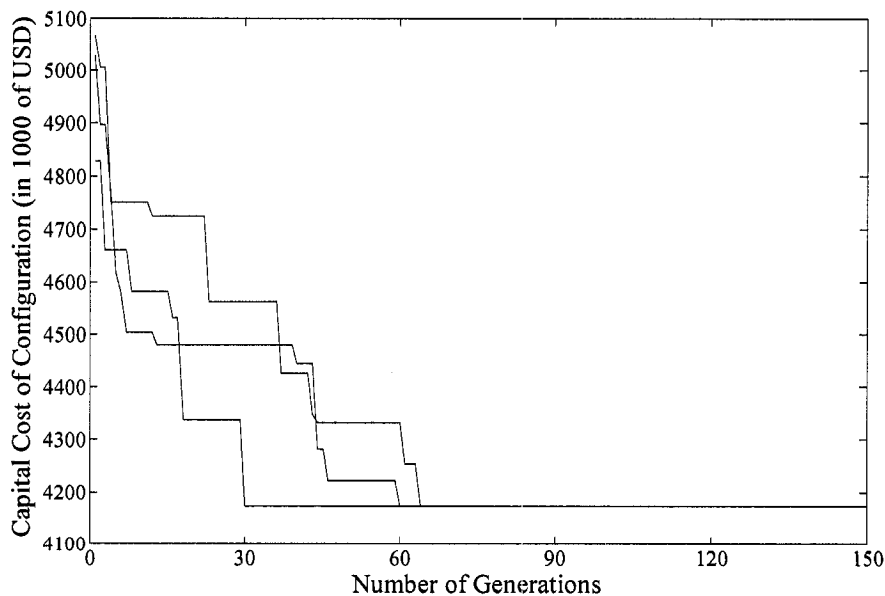

Figure (4.5) GA convergence curves for three different runs.

The developed GA permits keeping not only the best solution found along the search but the five best distinctive configurations some of which had the same value of objective

function (capital cost). The three runs represented in Figure 4.5 produced 15 best configurations (5 per run) out of which there are 9 distinct optimal configurations. Figure 4.6 presents the string representations of these configurations, the first of which is fully represented in Figure 4.7.

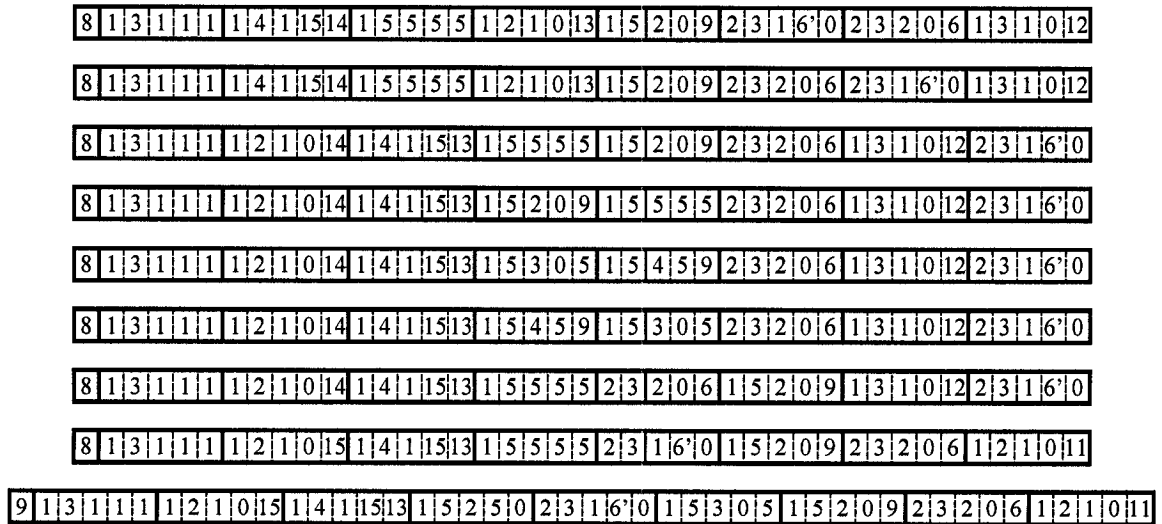

Figure (4.6) String representations of 9 distinctive optimal configurations for the case study.

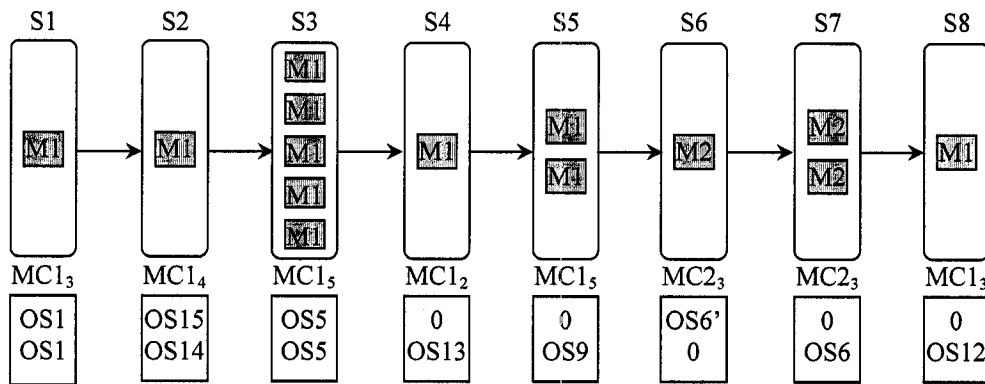

Figure (4.7) One of the optimal multiple-aspect configurations for the case study (first in Figure 7).

The results presented show that more than one configuration have the same optimal capital cost. All these configurations are composed of 14 machines but have different number of stages, machine arrangement in the different stages, selected machine configurations and the operation clusters assigned to these machines.

The variety of optimal solutions obtained highlights the advantages of the developed optimization model. First, the model is general and flexible regarding the selection of the number of production stages. The produced optimal configurations include 8-stage and 9-stage configurations. This provides more freedom and flexibility in designing the system. Second, the developed GA is capable of producing the best solution as well as other near-optimal ones, which allows more latitude in using other system objectives and criteria for differentiating among these solutions. This is particularly important in dealing with RMS, which might require using other considerations such as the effect of reconfiguration smoothness (RS) (Youssef and H. ElMaraghy 2006a) in the selection of system configurations at the beginning of each configuration period. Other objectives such as system availability can also be accommodated in that model to distinguish between the various economical configurations being produced.

The computation time required by the developed MATLAB toolbox to produce these solutions based on the presented optimization model was on average about 4 min/run on a Pentium 4 3.4 GHz PC with 1.0 GB memory. This is a very reasonable time considering the large solution space and the numerous constraints that are difficult to satisfy.

It is noticeable from the outcomes of optimization that an economical configuration is not necessarily the most compressed one (i.e. the configuration where all stages are visited by all product types). In fact, the obtained optimal configurations have some stages that are being used by only one of the two product types. This highlights another advantage of the presented model, which allows the outcomes of optimization to decide whether the stages would be used to serve single or multiple parts.

## 4.6 Optimization Using Tabu Search

A second powerful meta-heuristic optimization technique was needed in order to validate the results obtained by GAs. Tabu Search (TS) (Glover 1986), together with Genetic Algorithms (GAs) (Holand 1975) and Simulated Annealing (SA) (Kirkpatrick *et al.* 1983), was evaluated in the widely referenced report by the Committee on the Next Decade of Operations Research (CONDOR 1988) to be “extremely promising” for the future treatment of practical applications (Glover 1999). This evaluation has been amply

confirmed by the subsequent rapid and sustained growth of TS applications in a wide variety of fields. Pure and hybrid TS approaches have set new records in finding better solutions to problems in production planning and scheduling, resource allocation, network design and routing in telecommunications and many other areas. Literature of the above-mentioned applications of TS can be found in Glover's book (1999). Furthermore, the superiority of TS over the other two meta-heuristics, GAs and SA, has been demonstrated in a number of applications such as Very Large Scale Integration (VLSI) application in electronics (Youssef *et al.* 2001) and free-form surface fitting application in reverse engineering (Youssef 2001) in terms of the number of objective number evaluations and the quality of results. This gives some insight into the possibilities that can be achieved using TS. These reasons lead to the choice of Tabu Search (TS) as the second technique to solve the same optimization problem in quest of validation and comparison of results.

The Tabu Search (TS) algorithm was originally developed by Glover (1986) for solving combinatorial optimization problems. For this reason, the development of TS techniques is concerned in most of the published research work with combinatorial problems. The application of TS in continuous optimization is still considered in its infancy stage. Franze and Speciale (2001) briefly classified and described the main continuous approaches to Tabu Search. The first approach (Battiti and Tecchiolli 1994) is based on discretization and is adapted from the Reactive Tabu Search (RTS) algorithm that was introduced in the same paper originally for combinatorial optimization and proved to be very efficient. The second approach (Battiti and Tecchiolli 1996) is a hybrid one based on the identification of the most promising hyper boxes in the search space with a different level of abstraction through a combinatorial component (RTS) and accordingly running a stochastic local optimizer (Affine Shaker) for the sake of arriving at the different optimal points and this approach is named Continuous Reactive Tabu Search (C-RTS). The third approach is based on the use of hyper balls with given radii instead of boxes and that was introduced by Hu (1992) and adopted by Siarry and Berthiau (1997) and Chelouah and Siarry (2000) who showed that the second approach (C-RTS) obtained the best results when compared to other available methods. Youssef

(2001) improved the C-RTS and introduced the Modified Continuous Reactive Tabu Search (M-C-RTS) which is the algorithm adopted in this research work to be applied to the continuous optimization of the multiple-aspect RMS configurations. Appendix C provides a brief idea about the use of Tabu Search (TS) and its variants, RTS and M-C-RTS, in optimization.

## 4.7 Tabu Search Applied to the Case Study

A toolbox was developed for the M-C-RTS algorithm using MATLAB software and this optimization technique was applied to the same case study with the purpose of validation and comparison with the results of the GAs. The initial stage of the M-C-RTS stops when either the number of iterations reaches 50 or 25 iterations passes without improvements in both the best solution and the number of local optima found so far. Each local optimizer run in the following stages (second and third stages) is treated as an additional iteration. Refer to Section C.4 in Appendix C for the description of the different stages in M-C-RTS.

The same optimal cost of the manufacturing system configuration of 4.174 million US Dollars, previously obtained by GAs, was obtained consistently in most of the performed runs. Figure 4.8 demonstrates a sample of the TS convergence curves that reached this same value as obtained in various other runs. The developed TS permits keeping not only the best solution found along the search but the five best distinctive configurations almost all of which had the same value of objective function (capital cost). The computation time required by the developed MATLAB toolbox to produce these solutions was on average about 20 min/run on a Pentium 4 3.4 GHz PC with 1.0 GB memory.



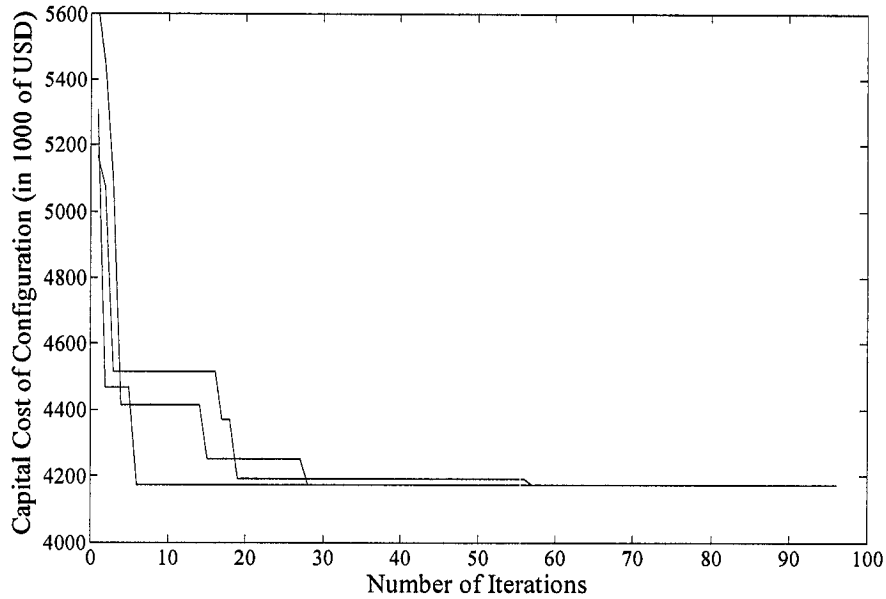

**Figure (4.8) M-C-RTS convergence curves for three different runs.**

It is noticeable from comparing the outcomes of optimization and the performance of both optimization techniques, GAs and TS, that the final results were consistent, which validates the optimization model developed. In addition, GAs was more efficient compared to TS in terms of the average time/run. On the other hand, TS proved to be more powerful in terms of its capability to produce multiple near-optimal solutions with same objective function value, the best value arrived at, which is very useful in case of having other considerations in the optimization process such as reconfiguration smoothness across the planning horizon of the manufacturing system.

## 4.8 Summary and Conclusions

It is essential to consider various aspects in the selection of system-level configurations for any manufacturing system including Reconfigurable Manufacturing Systems (RMS). This chapter presented a model for optimizing the capital cost of multiple-aspect RMS configurations that can produce a number of parts using Genetic Algorithms (GAs) and Tabu Search (TS). The proposed model includes a large number of parameters and several types of constraints leading to a complicated problem in terms of constraint satisfaction and generation of feasible solutions. A novel procedure was developed and utilized to overcome this problem. It is based on mapping of the decision

variables from their original discrete domain into a continuous domain of variables. The new continuous domain of variables not only guarantees the satisfaction of the specified constraints but also provides variables that are not function of the number of stages of the candidate configurations. This produces solution strings that are easy to manipulate using different types of operators, such as crossovers or mutations, without violating the constraints or changing the size of the solution string. In addition, the developed procedure drastically reduces the number of control variables and the size of the search space. Accordingly, Genetic Algorithms (GAs) and Tabu Search (TS) were successfully implemented to optimize the new set of variables for which a decoding algorithm was developed to evaluate and compare different feasible alternatives. The developed optimization tools using GAs and TS are capable of producing more than one alternative configuration with the best-achieved capital cost of investment.

A toolbox was developed using MATLAB software for implementing the proposed optimization model. A case study was presented to demonstrate the use of the developed model and the constraint satisfaction procedure. Good results were obtained in reasonable time. The results provide different system configuration alternatives with the same near-optimal capital cost. These alternatives would be helpful to the system designer in selecting the best configuration at the beginning of each configuration/design period. The designer may also take other measures into consideration such as reconfiguration smoothness through out the manufacturing system lifetime.

Finally, it is important to point out that the developed model and procedures are general and can be applied to complex parts with large number of features and systems with large number of stages and large number of available resources in reasonable time. In addition, they are applicable to the configuration selection of any manufacturing system with similar structure and are not limited to Reconfigurable Manufacturing Systems.

The next chapter extends the optimization model provided in this chapter to consider the effect of machine availability on the throughput (production rate) analysis and accordingly on the optimization results.

## 5. AVAILABILITY CONSIDERATIONS IN OPTIMIZING MULTIPLE-ASPECT RMS CONFIGURATIONS

This chapter extends the model for optimizing the capital cost of multiple-aspect RMS configurations, presented in the previous chapter, to incorporate the effect of machine availability based on the work done by Youssef and H. ElMaraghy (2006d). The chapter starts by describing the use of the Universal Generating Function (UGF) technique in the assessment of steady-state availability and expected production rates (throughput) of multi-state manufacturing systems (MSMS) capable of producing multiple-parts based on the work done by Youssef *et al.* (2006b). Accordingly, the modified mathematical model considering machine availability is presented and case study results of using GAs and M-C-RTS to solve the new optimization problem are then reported and compared for validation. Analysis of different cases of availability consideration (infinite buffer capacity and no buffer capacity) is performed and results are compared to the case of not considering machine availability. The first stage of the overall RMS Configuration Selection Approach is then concluded.

### 5.1 Availability Assessment of MSMS Using UGF

The selection of manufacturing systems configurations has an important impact on their performance. Different types of manufacturing systems performance measures are reviewed in (Hon 2005). Availability, as a performance measure, reflects the ability of a manufacturing system to satisfy demand requirements. The evaluation of availability of a manufacturing system is influenced by the availability and arrangement of its individual components. H. ElMaraghy *et al.* (2005) introduced the notion of availability as a functional requirement and used it to compare manufacturing systems complexity.

Most manufacturing systems (e.g. dedicated manufacturing lines, flexible and potentially reconfigurable manufacturing systems) are typically composed of a group of machines/stations in a specific arrangement. These individual machines/stations can have either identical or different performance levels (production rates). In addition, each of these individual machines/stations has several performance states (e.g. operating, idle,

down or under repair). Accordingly, a manufacturing system may have a finite number of performance levels. Therefore, it belongs to the category of Multi-State Systems (MSS) (Lisnianski and Levitin 2003).

Traditional techniques for assessment of MSS availability include Boolean-based methods, such as minimal cut sets (Aven 1985) and fault tree technique (Vesely *et al.* 1981), and stochastic-based methods, mainly Markov and semi-Markov processes (Limnios and Oprisan 2001). These techniques are inefficient and extremely time consuming if applied to large MSS because of the high number of system states (Lisnianski and Levitin 2003).

The Universal Generating Function (UGF) technique, first introduced by Ushakov (1986), proved to be efficient in evaluating the reliability (Levitin and Lisnianski 2000) and availability (Levitin and Lisnianski 1999a) of large MSS. However, it has never been applied to manufacturing systems. In addition, the application of UGF to MSS to date is limited to the evaluation of systems with single type of output performance. A modification of the original method to generalize its use and extend it to MSS with multiple types of output performance is needed in order to enable the application of the UGF technique to manufacturing systems capable of producing multiple part types simultaneously.

## 5.1.1 Universal Generating Function (UGF)

### 5.1.1.1 Brief Description

The UGF, introduced in (Ushakov 1986), enables the solution of various combinatorial problems. In particular, the UGF enables one to assess availability/reliability of Multi-State Systems (MSS). The UGF of the distribution of a discrete random variable  $X$  (can be any stochastic performance level), which can have  $K$  values  $(a_1, a_2, \dots, a_K)$ , is the function  $U(Z)$  defined for all real numbers  $Z$  by:

$$U(Z) = \sum_{i=1}^K p_i Z^{a_i}, \quad (5.1)$$

where  $p_i$  is the probability that the random variable  $X$  under consideration takes the value  $a_i$ , and  $Z$  is the argument of the generating function.

Consider systems described as reducible structures, i.e., structures that can be represented as compositions of serial and parallel connections of a group of components (e.g. manufacturing systems). A characteristic property of such systems is that each of them can be reduced to a single equivalent component by means of a finite number of operations. Composition operators are used to obtain the overall UGF of these systems by applying simple algebraic operations to the UGF of their components.

Steady-state availability of a repairable system, as a performance measure, is the probability that the system is, on average, performing satisfactorily over a reasonable period of time (Lewis 1987). To obtain steady state probability distributions of the different states of a multi-state system based on the probability distributions of the states of its individual components, the composition operator  $\Omega$  is defined by:

$$\Omega \left[ \sum_{all\_i} p_i Z^{a_i}, \sum_{all\_j} p_j Z^{a_j} \right] = \sum_{all\_i} \sum_{all\_j} p_i p_j Z^{f(a_i, a_j)}, \quad (5.2)$$

where the  $f(a_i, a_j)$  is defined according to the physical nature of the multi-state system performance and the interactions between its components. It expresses the entire performance level of a subsystem consisting of two components connected in parallel or in series in terms of the performance levels of its individual components.

Let  $\pi$  be the composition operator corresponding to a parallel connection of components and  $\sigma$  be the composition operator for a series connection. Composition operators  $\pi$  and  $\sigma$  are special cases of  $\Omega$ . For MSS that uses capacity of its components as its performance level (e.g. production rates in MSMS), the two operators,  $\pi$  and  $\sigma$  are defined as follows:

- The system total performance level is the sum of the performance levels of all components in parallel arrangement. Accordingly, the  $\pi$  operator is the product of the individual UGF of system components:

$$\pi \left[ \sum_{all\_i} p_i Z^{a_i}, \sum_{all\_j} p_j Z^{a_j} \right] = \sum_{all\_i} \sum_{all\_j} p_i p_j Z^{(a_i + a_j)}. \quad (5.3)$$

- The system total performance level is the minimum of the performance levels of all components in serial arrangement. Accordingly, the  $\sigma$  operator is applied to

choose the minimum performance level which corresponds to the bottleneck component:

$$\sigma \left[ \sum_{all\_i} p_i Z^{a_i}, \sum_{all\_j} p_j Z^{a_j} \right] = \sum_{all\_i} \sum_{all\_j} p_i p_j Z^{\min(a_i, a_j)}. \quad (5.4)$$

Evidently, a successive application of the composition operators,  $\pi$  and  $\sigma$ , reduces any reducible structure to an equivalent component. Consequently, the UGF of the entire multi state system is obtained in the form:

$$U(Z) = \sum_{all\_i} p_i Z^{a_i}. \quad (5.5)$$

A more detailed description of the Universal Generating Function (UGF) is provided in Appendix D.

### 5.1.1.2 UGF Modification

A modification to the UGF is proposed to consider systems with multiple independent types of output performance that collectively affect the assessment of the performance measure of the system. These output performance types (e.g. production rates for multiple part types in MSMS) can be expressed, in such a case, by a vector the length of which is the number of these types rather than a single variable. Accordingly, the UGF [Eq. (5.1)] can now be replaced by:

$$U(Z) = \sum_{i=1}^K p_i Z^{u_i}, \quad (5.6)$$

where  $u_i$  is the output performance types vector.

When applying the composition operators  $\pi$  and  $\sigma$  [Eqs. (5.3) and (5.4)], the summation/comparison are now vector operations applied to corresponding elements of vectors  $u_i$  and  $u_j$ . The resultant vector is the same size and includes the performance level corresponding to each type of output performance. The modified operators can now be expressed as follows:

$$\pi \left[ \sum_{all\_i} p_i Z^{u_i}, \sum_{all\_j} p_j Z^{u_j} \right] = \sum_{all\_i} \sum_{all\_j} p_i p_j Z^{(u_i + u_j)}, \quad (5.7)$$

$$\sigma \left[ \sum_{all\_i} p_i Z^{u_i}, \sum_{all\_j} p_j Z^{u_j} \right] = \sum_{all\_i} \sum_{all\_j} p_i p_j Z^{\min(u_i, u_j)}. \quad (5.8)$$

By applying the modified composition operators, the UGF of the entire multi state system can now be obtained in the form:

$$U(Z) = \sum_{all\_i} p_i Z^{u_i}. \quad (5.9)$$

## 5.1.2 Application to Manufacturing Systems

### 5.1.2.1 Multi-State Manufacturing System (MSMS)

One of the typical configuration structures used in different types of manufacturing systems, and adopted in this research work, is that of a flow line that allows paralleling of identical machines/stations with identical operation assignments in different production stages (see Section 3.1.1). The presence of multiple parallel machines/stations per stage reduces the effect of breakdown of any of the machines on the overall system performance thus the use of buffers is not always essential. Figure 3.1 shows an example of a manufacturing system configuration capable of producing two different part types simultaneously. The manufacturing system exemplified in this figure is a MSMS that falls under the category of reducible structures. Accordingly, the application of UGF in evaluating its availability is justified.

### 5.1.2.2 Steady-State Availability of MSMS

In the context of MSMS, the system availability, defined in Section 5.1.1.1, is considered a measure of the ability of the system to satisfy the demand requirements (i.e. required performance level). To evaluate the steady-state availability of the system, the availability of its individual components (machines/stations) and their individual performance levels for different types of output performance (i.e. production rates corresponding to multiple part types being produced) should be considered.

### 5.1.2.3 Application of UGF to MSMS

Consider the steady-state availability of each individual machine/station  $j$  with two possible states (operating or failed) to be  $A_j$ . The performance level of this machine/station is a vector of all output performance types (production rates



corresponding to each part type). This performance level can either be  $\theta$  (when failed) with probability of occurrence of  $(1-A_j)$  or  $NPR_j$  (when operating) with probability of occurrence of  $A_j$  where  $NPR_j$  is a vector of nominal production rates corresponding to each part type. In such case, the polynomial UGF [Eq. (5.6)] has only two terms as follows:

$$U_j(Z) = (1 - A_j)Z^0 + A_jZ^{NPR_j} . \quad (5.10)$$

Hence, the UGF of the entire Multi-State Manufacturing System (MSMS) can be obtained through successive applications of the composition operators  $\pi$  and  $\sigma$  as described in (Ushakov 1986) and (Levitin and Lisnianski 1999). It represents all the possible states of the system by relating the probability of each system state to the expected performance of the system in that state. The performance level of each state in the case of MSMS is  $PR$  where  $PR$  is a vector of the actual system production rates of the different part types obtained using UGF. Hence, the polynomial UGF of the entire system [Eq. (5.9)] is in the following form:

$$U(Z) = \sum_{all\_i} p_i Z^{PR_i} . \quad (5.11)$$

The MSMS availability is the probability that the system is in one of those states in which the system production rates satisfy the target demand requirements, which is the summation of the probabilities of occurrence of those states. Consider a manufacturing system that produces simultaneously a number of part types  $NP$ . Assuming that the set-up time to change over from one part type to another is negligible, a state of the system that satisfies the demand requirements has to fulfill the following condition (Nahmias 2001):

$$\sum_{p=1}^{NP} \frac{D(p)}{PR(p)} \leq 1, \quad (5.12)$$

where  $D$  is a vector of the demand requirements of the different part types being produced by the system and  $PR$  is a vector of the actual system production rates of those part types obtained using the UGF for that specific system state.

### 5.1.2.4 Illustrative Example

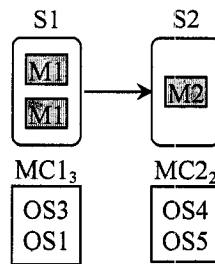

Figure (5.1) Representation of a simple MSMS.

A simple MSMS (Figure 5.1) that produces two part types simultaneously is used to illustrate the application of the UGF technique in evaluating system availability and its computational merits. Table 5.1 provides the steady state availability of the individual M-MC combinations in addition to the production rates of performing the OSs allocated to each stage of the system for each part type using the corresponding M-MC combination.

Table (5.1) Example data.

M-MC	Steady-State Availability	OS (part type)	Production Rate in parts/hour
MC1 <sub>3</sub>	0.92	OS3 (1)	120
		OS1 (2)	180
MC2 <sub>2</sub>	0.88	OS4 (1)	200
		OS5 (2)	370

The UGF of the first stage can be obtained by applying the  $\pi$  operator [Eq. (5.7)] to the two parallel machines as follows:

$$\begin{aligned}
 U_{stage1}(Z) &= \pi \left[ \left( 0.08Z \begin{bmatrix} 0 \\ 0 \end{bmatrix} + 0.92Z \begin{bmatrix} 120 \\ 180 \end{bmatrix} \right) \left( 0.08Z \begin{bmatrix} 0 \\ 0 \end{bmatrix} + 0.92Z \begin{bmatrix} 120 \\ 180 \end{bmatrix} \right) \right] \\
 &= 0.0064Z \begin{bmatrix} 0 \\ 0 \end{bmatrix} + 0.1472Z \begin{bmatrix} 120 \\ 180 \end{bmatrix} + 0.8464Z \begin{bmatrix} 240 \\ 360 \end{bmatrix}
 \end{aligned}$$

The UGF combined common terms and thus reduced the number of system states from 4 (2\*2) into the above three states corresponding to three vectors of production rates.

The UGF of the system can be obtained by applying the  $\sigma$  operator [Eq. (5.8)] to the two serial stages as follows:

$$U_{system}(Z) = \sigma \left[ \left( 0.0064Z \begin{bmatrix} 0 \\ 0 \end{bmatrix} + 0.1472Z \begin{bmatrix} 120 \\ 180 \end{bmatrix} + 0.8464Z \begin{bmatrix} 240 \\ 360 \end{bmatrix} \right), \left( 0.12Z \begin{bmatrix} 0 \\ 0 \end{bmatrix} + 0.88Z \begin{bmatrix} 200 \\ 370 \end{bmatrix} \right) \right]$$

$$= 0.12563Z \begin{bmatrix} 0 \\ 0 \end{bmatrix} + 0.12954Z \begin{bmatrix} 120 \\ 180 \end{bmatrix} + 0.74483Z \begin{bmatrix} 200 \\ 360 \end{bmatrix}$$

The UGF combined common terms and thus reduced the number of system states from 6 ( $3*2$ ) into the above three states corresponding to three vectors of production rates. Thus the UGF reduced the overall number system states from 8 ( $2*2*2$ ) into these three states. Now, consider that the system demand requirements are 100 parts/hour for part 1 and 120 parts/hour for part 2. All three states are checked to find which of them satisfy the condition expressed by Eq. (5.12) as follows:

The first state: 
$$\sum_{p=1}^{NP} \frac{D(p)}{PR(p)} = \frac{100}{0} + \frac{120}{0} = \infty > 1$$

The second state: 
$$\sum_{p=1}^{NP} \frac{D(p)}{PR(p)} = \frac{100}{120} + \frac{120}{180} = \frac{9}{6} = 1.5 > 1$$

The third state: 
$$\sum_{p=1}^{NP} \frac{D(p)}{PR(p)} = \frac{100}{200} + \frac{120}{360} = \frac{5}{6} = 0.833 \leq 1$$

Therefore, the first two states do not satisfy the condition expressed by Eq. (5.12) and only the third state satisfies the condition. Hence, the system steady-state availability is equal to 0.74483 (the sum of probabilities of the satisfactory states, which is only the third state). This means that the system satisfies the demand requirements during 74.5% of the considered period of time.

### 5.1.3 A Case Study Applying the Use of UGF in Availability Assessment of MSMS

In order to demonstrate the use of the modified UGF in comparing manufacturing system configurations based on availability, a case study is applied using the two example parts, ANC-90 and ANC-101, previously described in Section 4.5.1 of the previous chapter.

Consider the case of selecting a MSMS configuration that is capable of simultaneously producing part A (ANC-90) with a rate of 120 parts/hour and part B (ANC-101) with a rate of 180 parts/hour. Table B.5 (Appendix B) provides the initial cost and availability data of all the resources (M-MC combinations) that can be used in the system. Figure 5.2 describes three feasible configurations that satisfy the demand requirements of the system. NMS stands for the number of machines per stage and  $OS_i$  is the OS allocation corresponding to part  $i$ . Table 5.2 provides the capital cost of these configurations, using the cost model and data provided in Chapter 4, and the results of applying the UGF technique to evaluate their MSMS availability.

Configuration 1							
S	1	2	3	4	5	6	7
M	1	1	1	1	2	1	1
MC	2	3	2	5	2	1	5
NMS	2	3	3	7	7	3	4
$OS_A$	0	1	14	5	6	0	3
$OS_B$	1	15	13	5	6	11	9

Configuration 2							
S	1	2	3	4	5	6	7
M	1	1	1	1	2	1	1
MC	2	2	2	5	2	2	5
NMS	2	4	3	7	7	2	4
$OS_A$	0	1	14	5	6	0	3
$OS_B$	1	15	13	5	6	11	9

Configuration 3							
S	1	2	3	4	5	6	7
M	1	1	1	1	2	1	1
MC	3	3	2	5	2	2	5
NMS	2	3	3	7	7	2	4
$OS_A$	0	1	14	5	6	0	3
$OS_B$	1	15	13	5	6	11	9

Figure (5.2) Possible configurations for the system.

Table (5.2) Availability and costs of the three configurations.

Configuration	1	2	3
Capital Cost (in 1000 of USD)	7700	7700	7773
Availability	0.64932	0.64617	0.79667

The results (Table 5.2) indicate that configuration 1 is preferred to configuration 2 based on its availability since both configurations have identical capital costs. This is a common situation when the designer of a manufacturing system has to select among alternative configurations with similar cost based on other performance criteria such as availability. Configuration 3, which has a better system availability compared to configuration 1 (23% higher), is more expensive (\$73,000 more). The developed UGF-based availability evaluation tool is helpful in making these trade-off decisions.

## 5.2 Expected Production Rate and System Utilization

### Evaluation of MSMS Using UGF

When considering the individual machine availability in manufacturing systems analysis, it is essential to evaluate the expected production rate (throughput) of the manufacturing system configuration corresponding to each part type in order to assess the feasibility of this configuration in terms of meeting the demand requirements over a specific period of time. The previous section presented the use of the UGF technique in the assessment of MSMS availability which proved to be very powerful and capable of evaluating large systems in reasonable time. The use of the UGF technique in analyzing MSMS capable of producing multiple-part types is not limited to system availability but can be extended to other important performance measures on the system level such as expected production rate (throughput) and system utilization.

The expected production rates of the MSMS corresponding to the different part types can be deduced from Eq. (5.11) as follows:

$$EPR = \sum_{all\_i} p_i PR_i, \quad (5.13)$$

where  $EPR$  is a vector of the expected values (expectations) of the actual production rates of the MSMS corresponding to different part types,  $PR_i$  is a vector of the actual system production rates of the different part types obtained using the UGF for state  $i$  and  $p_i$  is the probability of that state of the system.

Accordingly, to check the feasibility of a MSMS configuration in terms of fulfilling the demand requirements of different part types over a period of time, the condition to be satisfied [Eq. (5.12)] is in the form:

$$\sum_{p=1}^{NP} \frac{D(p)}{EPR(p)} \leq 1. \quad (5.14)$$

The left hand-side of Eq. (5.14) represents the system utilization of the configuration which has to be below 1 (100%) so that the system is not over utilized as shown in the condition. On the other hand, the closer the system utilization to 100%, the closer the system is to providing exactly the capacity needed when it is needed which is highly recommended especially when dealing with RMS.

### 5.3 Incorporating Availability in the Mathematical Model for RMS Configuration Selection

The mathematical model for optimizing multiple-aspect RMS configurations, presented in Chapter 4, can now be modified to incorporate the effect of machine availability based on the use of the UGF technique described in Sections 5.1 and 5.2 of this chapter.

The results presented in Chapter 4 and in Section 5.1 of this chapter showed that for the same near-optimal capital cost of configuration, different configuration alternatives were obtained. Accordingly, there was a need for a performance measure other than cost in order to distinguish between those economic alternatives. System availability was chosen to play this role due to its importance as highlighted earlier in this chapter. In spite of its importance, system availability was still given a second priority in distinguishing between different configuration alternatives while the first priority was kept for capital cost due to the fact that the constraints already ensure that the selected configurations are capable of meeting the demand requirements over the designated period of time while reducing the cost remains to be the most important driver in selecting system configurations. Since the capital cost is to be minimized while the system availability is to be maximized, therefore, the utility function developed adds the cost to  $(1 - AV)$  where  $AV$  is the system steady-state availability obtained using the UGF technique. The

relatively small magnitude of the value of  $AV$ , 0 to 1, relative to the cost (in 1000 USD), in the order of thousands, assures that both objectives are not competing. Thus adding the availability to the objective function is just used to help distinguish between configurations with equal cost. Hence the original mathematical model provided in Section 4.1 of Chapter 4 remains unchanged except for eliminating the second assumption in addition to two other main modifications:

1. The objective function [Eq. (4.1)] is modified to the following utility function:

$$\text{Min. } U = CC(NS, M, MC, NMS) + [1 - AV(NS, M, MC, NMS, OS)], \quad (5.15)$$

where  $CC$  is the capital cost of the configuration as defined in Eq. (4.1) and  $AV$  is the system steady-state availability obtained using the UGF technique as described in Section 5.1 of this chapter.

2. The capacity constraint [Eq. (4.8)] is now modified to incorporate the effect of machine availability referring to Eq. (5.14) as follows:

$$\sum_{p=1}^{NP} \frac{DS(p)}{EPR(p)} \leq 1, \quad (5.16)$$

where  $DS(p)$  is the demand requirement of part type  $p$  as defined in Eq. (4.8) and  $EPR(p)$  is the expected value (expectation) of the actual production rate of the system corresponding to part type  $p$  obtained using the UGF technique as described in Section 5.2 of this chapter.

The constraint satisfaction procedure described in Section 4.3 is still valid for the new model except that it no longer guarantees the satisfaction of the new capacity constraint [Eq. (5.16)]. Accordingly, a second penalty function was added to the utility function other than the one defined in Section 4.3.6 to ensure that the search attempts to satisfy this constraint. If the left hand-side of the condition in Eq. (5.16) exceeds 1, a penalty value of  $MI$  multiplied by the sum of the demand requirements multiplied by the exceeded value is added to the objective function value.  $MI$  is used just to ensure that the penalty value is large enough to drive the search away from the infeasible region. In spite of the use of this penalty function, the possibility of generating infeasible solutions that violate the capacity constraint [Eq. (5.16)] increased drastically with the modified model due to the negative influence of incorporating individual machine availability in the



expected values of system throughput. Although these infeasible solutions are obviously penalized and accordingly lose their chances of being selected when compared to other feasible solutions, they still have a negative influence by distracting the search process seeking optimality.

## 5.4 Case Study

The new optimization problem, based on the modified model, was applied to a case study based on the two example parts, ANC-90 and ANC-101, and the available/obtainable resources previously described in Section 4.5.1 of Chapter 4. Both techniques, GAs (Appendix A) and M-C-RTS (Appendix C), were implemented for optimization after modifying the developed toolbox to accommodate for the changes in the model. The optimization parameters in both techniques had to be modified and the search had to be more exhaustive in order to overcome the increased level of difficulty of arriving at a near-optimal solution due to the increased number of infeasible configurations being generated along the search because of the new capacity constraint [Eq. (5.16)] based on considering the individual machine availability. Both optimization techniques are capable of generating a number of near-optimal configurations in each run. This number is the minimum of two values; a predefined number (default is 10) or the number of configurations within a specific predefined tolerance limit, regarding their evaluation, compared to the best of these configurations (default is 5%).

Table 5.3 provides the new parameters used for GAs in the optimization of the multiple-aspect configuration based on the modified model.

Table (5.3) Parameters used in real-coded GAs with the modified model.

<b>Parameter</b>	<b>Value</b>
Population size	200
Number of generations	700
Number of times of cross-over application (arithmetic cross-over, simple cross-over and heuristic cross-over)	Six times for each operator
Number of times of mutation application (uniform mutation, boundary mutation, non-uniform mutation and whole non-uniform mutation)	Twelve times for each operator

On the other hand, the initial stage of the M-C-RTS used with the modified optimization model stops when either the number of iterations reaches 300 or 150 iterations passes without improvements in both the best solution and the number of local optima found so far. Each local optimizer run in the following stages (second and third stages) is treated as an additional iteration. Refer to Section C.4 in Appendix C for the description of the different stages in M-C-RTS.

Now, consider the case of having a configuration period (CP) with a duration of 1.5 years where part ANC-90 (part A) is to be produced with a rate of 120 parts/hour and part ANC-101 (part B) is to be produced with a rate of 180 parts/hour simultaneously. The annual interest rate is assumed to be 12%. The system designer specified the maximum number of stages to be 10 and the maximum number of parallel machines per stage to be 8. The maximum allowable budget for initial investment is 60 million US Dollars.

#### **5.4.1 Optimization Results Using GAs**

A number of optimization runs were applied to the modified model using real-coded GAs with the parameters identified in Table 5.3. The results were fluctuating compared to the consistent results with the original less complicated model. Across all the runs, the best obtained near-optimal capital cost of the manufacturing system configuration that satisfies the demand requirements of the case study is 7.369 million US Dollars while the average obtained near-optimal cost over six runs was 7.75 million US Dollars. Figure 5.3 demonstrates a sample of a GA convergence curve for a run that produced a near-optimal configuration (Figure 5.4) that has a capital cost of 7.719 million US Dollars.

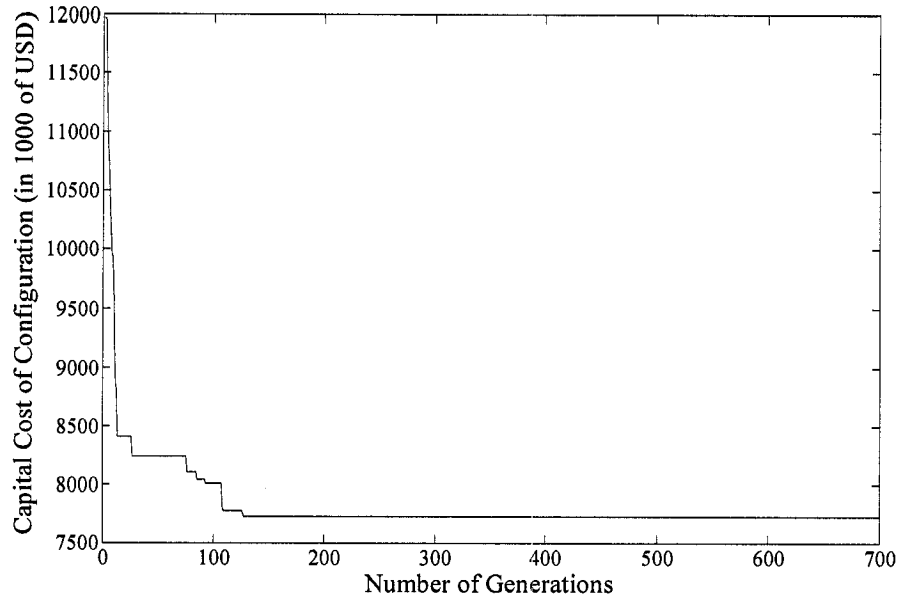

Figure (5.3) A sample GA convergence curve.

S	1	2	3	4	5	6
M	1	1	1	1	2	1
MC	3	5	5	5	2	3
NMS	2	6	7	4	6	3
OS <sub>A</sub>	1	14	5	0	6	3
OS <sub>B</sub>	1	16	5	9	6	12

Figure (5.4) A sample near-optimal configuration.

The near-optimal configuration illustrated in Figure 5.4 has the following characteristics:

- Capital cost of the configuration in present value = 7.7186 million US Dollars
- Initial investment in the configuration = 27.6000 million US Dollars
- System availability of the configuration = 68.624%
- System expected production rate of the configuration for part A = 355 parts/hour
- System expected production rate of the configuration for part B = 275 parts/hour
- System utilization of the configuration = 99.2%
- Overall utility function evaluation of the configuration = 7,718.96644

The computation time required by the developed MATLAB toolbox to produce these solutions based on the modified optimization model was on average about 1.4 hour/run on a Pentium 4 3.4 GHz PC with 1.0 GB memory compared to 4 min/run for the model that does not consider availability as reported in Chapter 4. This difference in time reflects the difference in the GA parameters being used in both cases.

### 5.4.2 Optimization Results Using M-C-RTS

A number of optimization runs were applied to the modified model using M-C-RTS with the parameters identified earlier at the beginning of Section 5.4. The results were also fluctuating compared to the consistent results with the original less complicated model. Across all the runs, the best obtained near-optimal capital cost of the manufacturing system configuration that satisfies the demand requirements of the case study is 7.617 million US Dollars while the average obtained near-optimal cost over five runs was 8.066 million US Dollars. Figure 5.5 demonstrates a sample of a M-C-RTS convergence curve for a run that produced a near-optimal configuration (Figure 5.6) that has a capital cost of 8.071 million US Dollars.

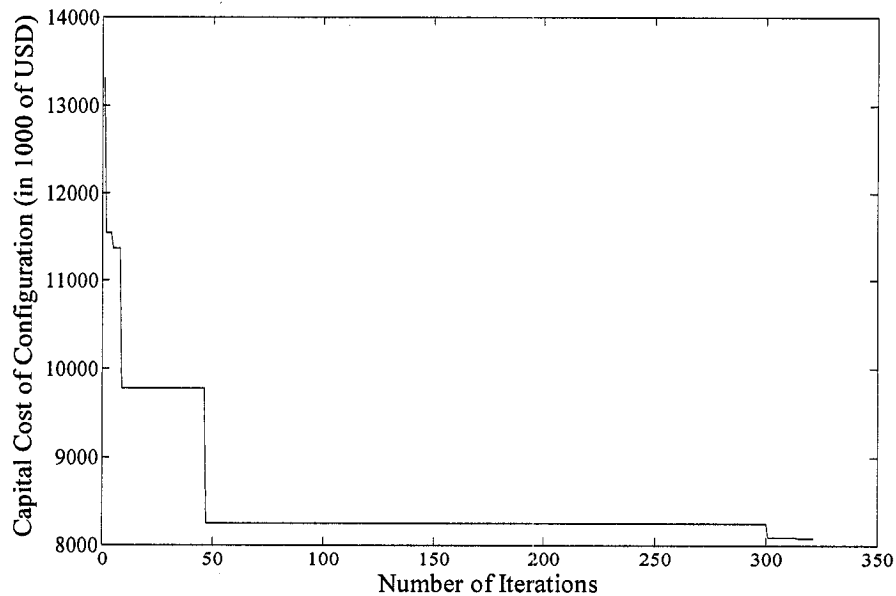

Figure (5.5) A sample M-C-RTS convergence curve.

<b>S</b>	<b>1</b>	<b>2</b>	<b>3</b>	<b>4</b>	<b>5</b>	<b>6</b>
<b>M</b>	1	1	1	1	2	1
<b>MC</b>	3	5	5	5	2	4
<b>NMS</b>	2	7	4	7	8	2
<b>OS<sub>A</sub></b>	1	14	3	5	6	0
<b>OS<sub>B</sub></b>	1	16	9	5	6	12

Figure (5.6) A sample near-optimal configuration.

The near-optimal configuration illustrated in Figure 5.6 has the following characteristics:

- Capital cost of the configuration in present value = 8.0710 million US Dollars
- Initial investment in the configuration = 28.8600 million US Dollars
- System availability of the configuration = 62.872%
- System expected production rate of the configuration for part A = 352 parts/hour
- System expected production rate of the configuration for part B = 282 parts/hour
- System utilization of the configuration = 98.0%
- Overall utility function evaluation of the configuration = 8,071.39725

The computation time required by the developed MATLAB toolbox to produce these solutions based on the modified optimization model was on average about 1.7 hour/run on a Pentium 4 3.4 GHz PC with 1.0 GB memory compared to 20 min/run for the case of not considering availability. This difference in time reflects the difference in the TS parameters being used in both cases.

### 5.4.3 Discussion of Case Study Results

The results of both optimization runs show that the system utilization for both near-optimal configurations was very close to 100%, which was consistently the case for the various performed runs. This proves that the choice of the configuration structure of a flow line that allows paralleling of machines in production stages was a good choice as it provides high flexibility in terms of capacity scalability, which leads to near-optimal configurations that provide almost exactly the capacity needed when it is needed.

It is noticeable from comparing the outcomes of optimization and the performance of both optimization techniques, GAs and TS, that the final results were fluctuating for both techniques, which is normal if the constraint satisfaction difficulty of the problem is taken into consideration. Still, though, the best and the average results for both techniques were very close which provides a good indication about the reliability of the optimization model. GAs was more efficient compared to M-C-RTS in terms of arriving at better solutions and its average time/run.

Other runs were performed for different demand scenarios (DSs) and GAs was more capable of arriving at better near-optimal configurations in most of the tested scenarios but still M-C-RTS was better in a few of them. The results of both techniques were consistent in some of them where satisfying the demand requirements was easier to achieve such as the case of a demand of only 220 parts/hour from part A in a duration of 1 year. Both techniques arrived at the same near-optimal solution consistently, which had a capital cost of 2.425 million US Dollars. This affirms the validity of the optimization procedure. The next section of this chapter provides a summary of these results and compares them with the case of not considering machine availability and the case of having infinite buffer capacity.

## **5.5 Analysis of Different Cases of Availability Consideration**

The developed MATLAB toolbox is capable of producing results for different cases in terms of availability consideration. This was utilized in performing an exhaustive number of runs for the purpose of analyzing the influence of incorporating machine availability on the outcome results of optimizing the multiple-aspect RMS configurations in terms of capital cost of configuration. Three different cases were investigated;

1. machine availability not considered,
2. machine availability considered with infinite buffer capacity and
3. machine availability considered with no buffer capacity.

The original model of the first case was described in details in Chapter 4 and a modification to this model provides the third case, which was described in this chapter. The second case is similar to the first case except for the capacity constraint. Both aim at

having each production stage independently capable of satisfying the demand requirements of the system. The only difference is that in the second case, the machine availability has to be incorporated in the capacity constraint [Eq. (4.8)], which accordingly becomes:

$$\sum_{p=1}^{NP} \frac{DS(p)}{n_s \times AMC_{m_s}(c_s) \times PROS_{p,m_s}(o_{p,s}, c_s)} \leq 1 \quad \forall s = 1, 2, \dots, NS. \quad (5.17)$$

Table 5.4 presents a summary of the results obtained for the three cases applied to 12 different demand scenarios. It provides the capital cost of the best obtained near-optimal configuration using both GAs and M-C-RTS for each of the 12 DSs in each of the three cases of availability consideration. Figure 5.7 illustrates these results by comparing the capital cost of the best obtained near-optimal configuration, using either GAs or M-C-RTS, for each of the three cases of availability consideration in each of the 12 DSs. Table 5.5 is an extension to Table 5.4 that provides in addition to the capital cost in 1000 of USD (CC) of the best obtained near-optimal configuration using either GAs or M-C-RTS, information regarding its physical configuration that reflects this cost. This information include the number of stages (NS), the total number of machines (NM) and the total number of removable modules (NRM) used in the best obtained near-optimal configuration for each of the three cases of availability consideration in each of the 12 DSs. Figures 5.8-5.10 further illustrate these results by comparing the number of stages (Figure 5.8), the total number of machines (Figure 5.9) and the total number of removable modules (Figure 5.10) used in the best obtained near-optimal configuration, using either GAs or M-C-RTS, for each of the three cases of availability consideration in each of the 12 DSs.



Table (5.4) Summary of results of analyzing different cases of availability consideration.

Demand Scenarios				Capital Cost of Best Obtained Near-Optimal Configuration (in 1000 of USD)					
DS#	Demand Requirements (in Parts/Hour)		Duration (in years)	Availability Not Considered		Availability Considered - Infinite Buffer Capacity		Availability Considered - No Buffer Capacity	
	Part A	Part B		GAs	TS	GAs	TS	GAs	TS
1	120	180	1.5	4.174	4.174	5.122	4.958	7.369	7.617
2	220	0	1.0	1.636	1.636	1.986	1.986	2.425	2.425
3	180	120	1.0	3.014	2.842	3.315	3.284	5.072	5.245
4	120	180	1.2	3.445	3.445	4.132	4.092	6.221	6.578
5	180	180	1.2	3.994	3.845	4.654	4.654	7.001	7.278
6	0	200	1.2	3.227	3.227	3.227	3.227	4.832	4.740
7	0	220	1.5	3.910	3.910	4.533	4.533	6.294	6.181
8	120	120	1.5	3.423	3.423	4.065	4.065	6.241	6.480
9	150	150	1.3	3.760	3.624	4.105	4.105	6.622	6.527
10	150	120	1.3	3.353	3.210	4.063	3.836	6.028	6.386
11	120	150	1.3	3.529	3.529	3.693	3.693	6.225	6.670
12	250	0	1.3	2.575	2.575	2.644	2.644	3.271	3.271

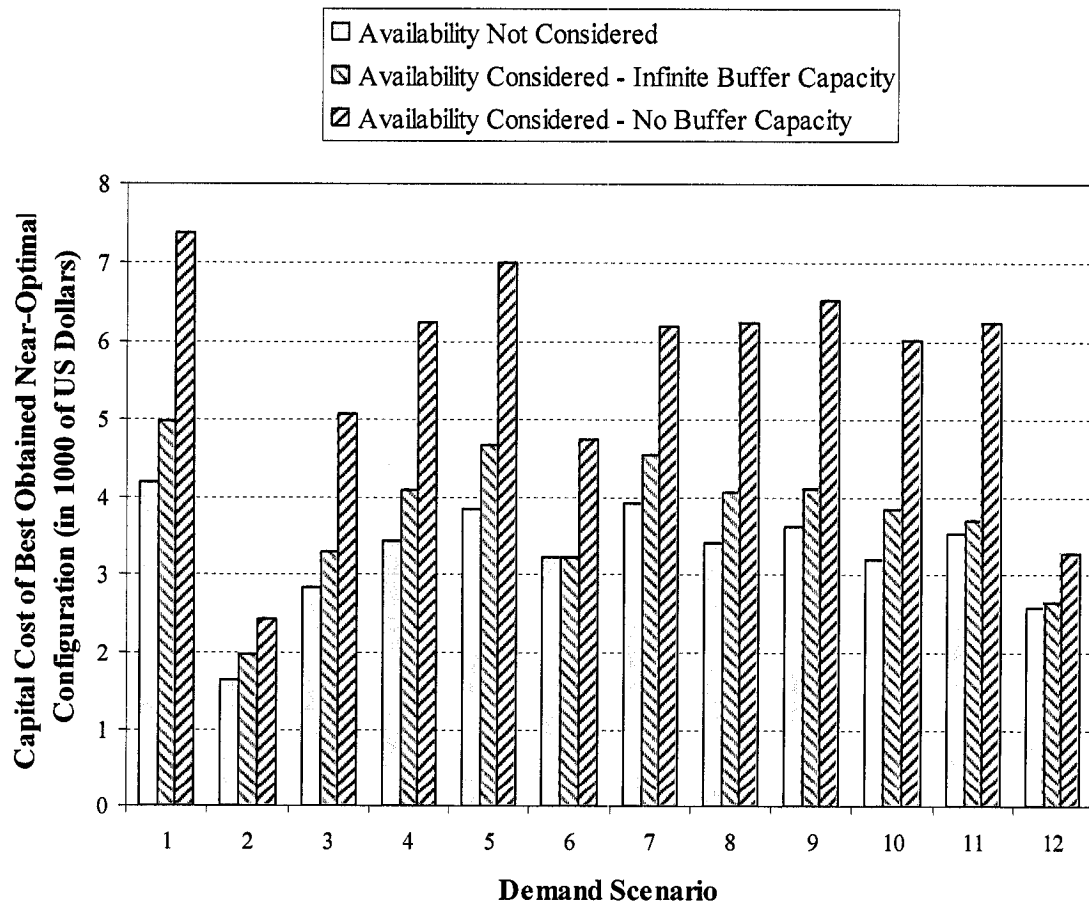

Figure (5.7) Comparing results for different cases of availability consideration.

Table (5.5) Information of best obtained near-optimal configurations for different cases of availability consideration.

DS#	Availability Not Considered				Availability Considered -- Infinite Buffer Capacity				Availability Considered -- No Buffer Capacity			
	CC	NS	NM	NRM	CC	NS	NM	NRM	CC	NS	NM	NRM
1	4.174	8	14	57	4.958	8	17	69	7.369	7	24	101
2	1.636	4	8	32	1.986	5	11	38	2.425	4	12	47
3	2.842	8	15	55	3.284	8	16	65	5.072	7	24	98
4	3.445	8	14	57	4.092	8	17	69	6.221	7	25	104
5	3.845	8	16	64	4.654	7	18	78	7.001	7	26	116
6	3.227	7	13	54	3.227	7	13	54	4.74	7	21	76
7	3.910	7	13	54	4.533	8	16	62	6.181	7	23	82
8	3.423	9	12	47	4.065	8	14	56	6.241	7	21	85
9	3.624	7	14	56	4.105	8	16	65	6.527	7	27	98
10	3.210	8	12	50	3.836	8	16	59	6.028	7	22	92
11	3.529	8	13	55	3.693	7	14	57	6.225	7	22	96
12	2.575	5	10	41	2.644	5	10	42	3.271	4	13	51

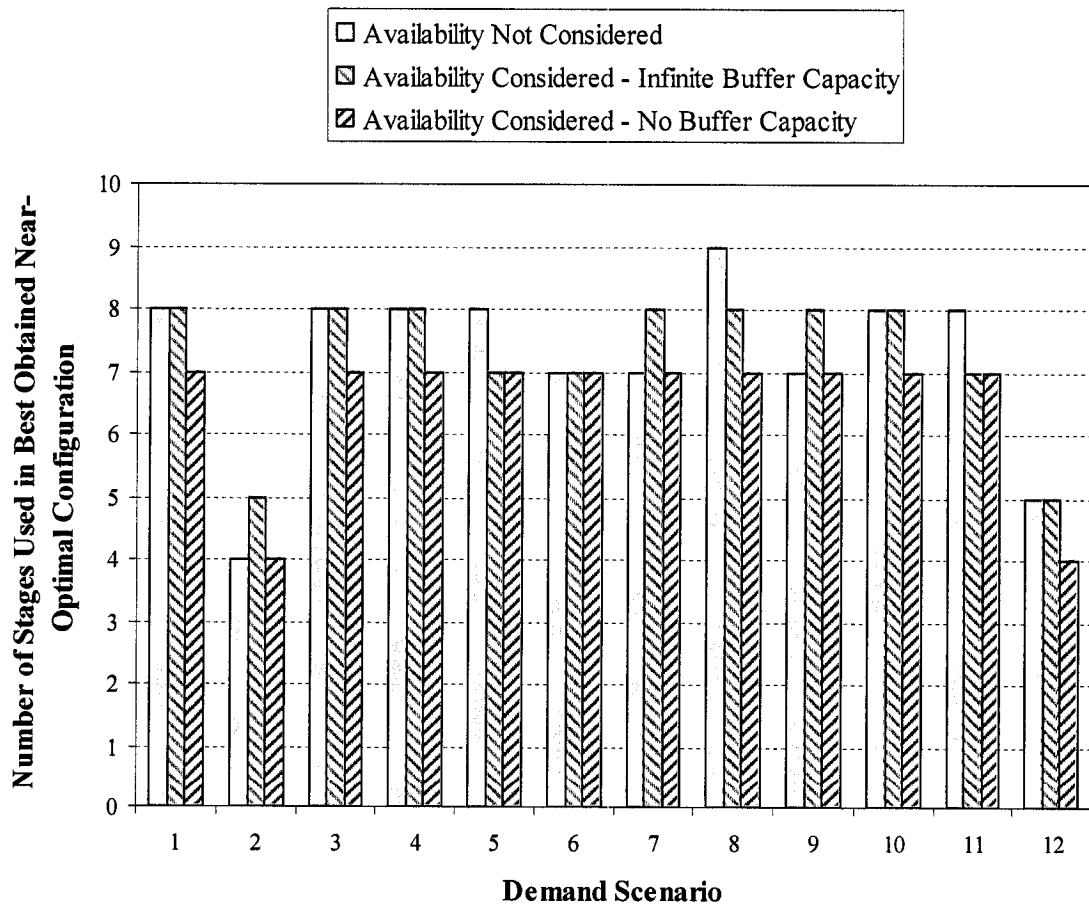

Figure (5.8) Comparing number of stages used in best obtained near-optimal configurations for different cases of availability consideration.

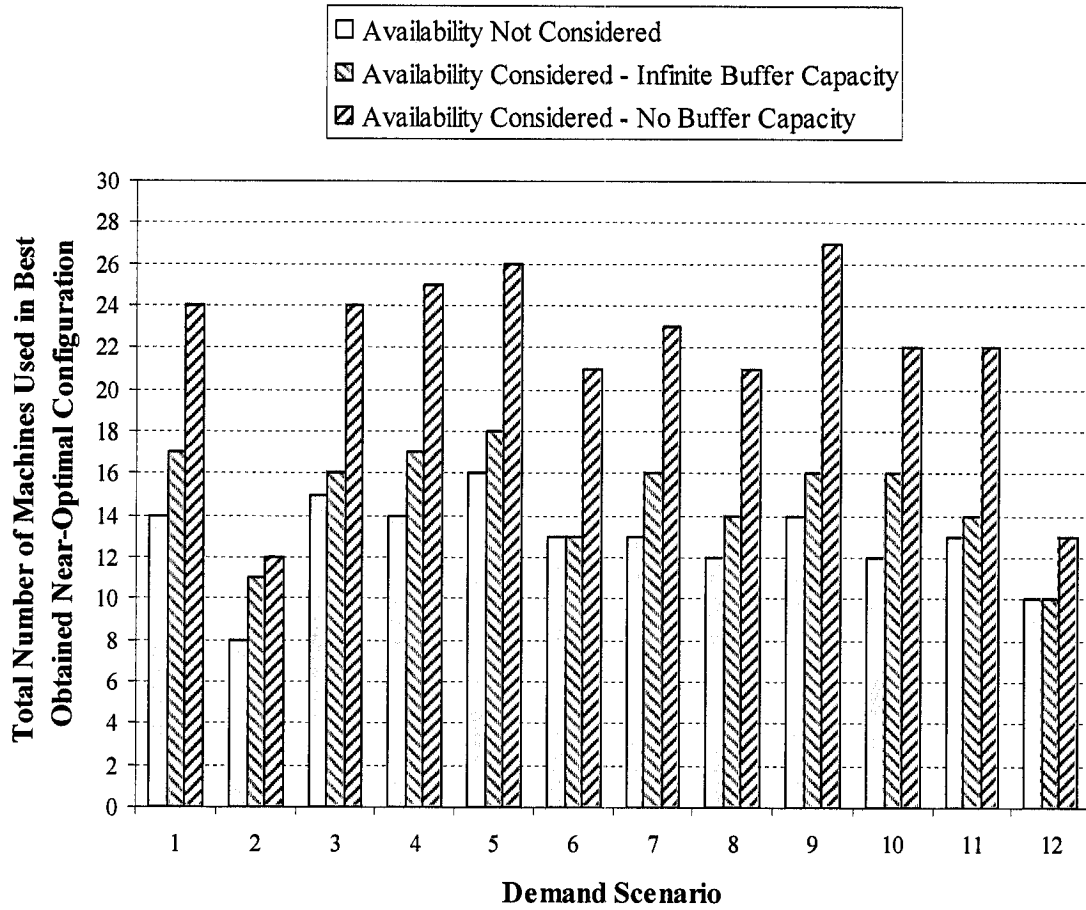
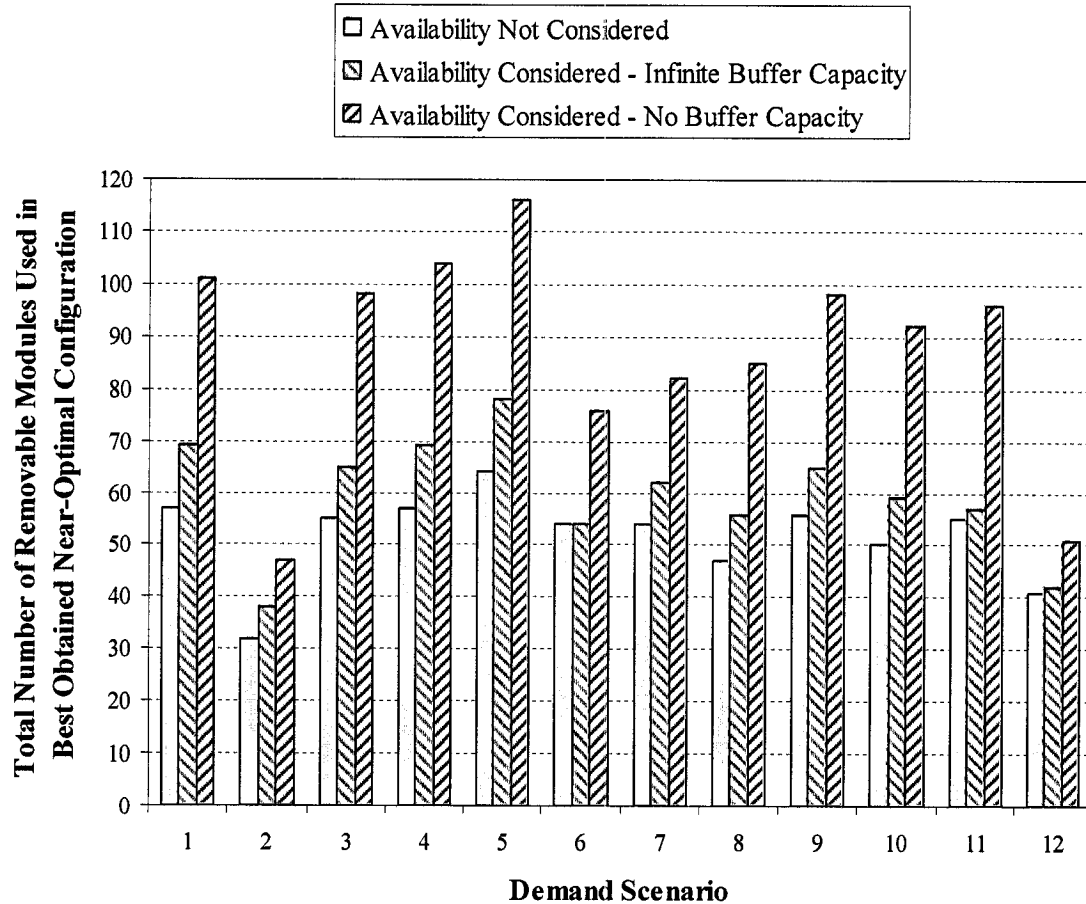

Figure (5.9) Comparing total number of machines used in best obtained near-optimal configurations for different cases of availability consideration.



**Figure (5.10) Comparing total number of removable modules used in best obtained near-optimal configurations for different cases of availability consideration.**

The results summarized in Tables 5.4-5.5 and illustrated in Figures 5.7, 5.9 and 5.10 highlight the influence of incorporating machine availability on the outcomes of optimization in terms of the capital cost of the best obtained near-optimal configuration for the three different cases which reflects the number of equipments used in these configurations in terms of the total number of machines and the total number of removable modules. It is quite obvious when comparing the results of case 1 (not considering availability) with the other two cases (availability considered) that, as expected, the capital costs of the near-optimal configurations increase when availability is incorporated due to the fact that more equipments (machines) are required in order to accommodate for the effect of machines downtime that was incorporated in the analysis so that the expectations of the system performance satisfy the demand requirements.

Now, comparing case 2 (infinite buffer capacity) with case 3 (no buffer capacity), the number of equipments (machines and modules) used and accordingly the capital costs of the near-optimal configurations increase drastically from case 2 to case 3. This is due to the fact that in the second case (infinite buffer capacity) the system is totally decoupled, which means that the state (idle or operating) of each individual component (machine) in the system is independent of the states of the rest of the components (machines) in the system. This enhances the overall performance of the system and reduces its degree of complexity. On the other hand, in the third case (no buffer capacity), the system is totally coupled, which means that the state of each individual component (machine) in the system is dependent on the states of the rest of the system components (machines). This reduces the overall performance of the system and accordingly the number of machines required to satisfy the demand requirements has to increase in order to accommodate for the occurrence of blockages and starvations in the different production stages that are anticipated in this case. In addition, this increases the degree of the complexity of the system.

The results summarized in Table 5.5 and illustrated in Figure 5.8 in terms of the number of stages used in the near-optimal configurations show that the number of stages is not directly related to the capital cost of the near-optimal configuration and is insensitive to availability consideration and capacity requirements. The reason behind this is the nature of the configuration structure that allows paralleling of machines per stage. This leads to accommodation for availability consideration and increased capacity requirements by adding more machines in parallel to the system rather than increasing the number of production stages. On the other hand, it is noticed that the number of stages used in the near-optimal configurations for the different demand scenarios is almost consistently averaging at seven or eight except for the second and last demand scenarios in which this number averages at four or five. The common aspect of these two scenarios is that in both of them only part A is being produced by the system while all the other demand scenarios have either part B or both parts being produced. This means that the factor that mostly influences the number of production stages, which reflects the length of the configuration, is the functionality requirements in terms of the parts being produced.

It is to be noted that the optimization results of both GAs and M-C-RTS were consistent for both the first and second cases in most of the considered demand scenarios while they were different but close for most of the considered DSs in the third case due to the increased level of difficulty in generating feasible configurations which causes distraction in the search for optimal solutions and accordingly influences the efficiency of optimization negatively. GAs arrived at better solutions for most of the scenarios in the third case and proved to be more capable for constraint-congested solution spaces, i.e. solution spaces where feasibility is difficult to achieve, while M-C-RTS was more consistent in arriving at optimal solutions in cases of relaxed solution spaces, i.e. solution spaces where feasibility is easier to achieve.

## 5.6 Summary and Conclusions

Availability of a manufacturing system provides a measure for its ability to meet targeted demand requirements. The use of the Universal Generating Function (UGF) technique in assessing the availability and the expected throughput (production rate) of Multi-State Manufacturing Systems (MSMS) has been introduced. One of the major contributions in the presented work is the modification of the original technique to be capable of dealing with multiple types of output performance. This allows evaluating the availability of manufacturing systems that produce more than one part type simultaneously. The application of the modified UGF to MSMS and its computational merits in terms of reduction in the number of system states were illustrated using an example. A case study shows that the UGF technique is a powerful tool for comparing different manufacturing systems configurations based on availability, and supporting the system designer in making the necessary tradeoffs decisions. The use of such a computationally efficient technique has an important significance in the field of manufacturing systems performance evaluation. It permits the evaluation of expected production rates, system availability and system utilization for large systems in reasonable time.

The model presented in Chapter 4 was modified to accommodate for the effect of machine availability on the analysis of the manufacturing system performance especially



regarding capacity of the system and its capability to satisfy its demand requirements. Accordingly, GAs and M-C-RTS capable of producing multiple near-optimal solutions were implemented to solve this new optimization problem. A case study was presented and the results using the developed MATLAB toolbox showed that both techniques fluctuated within an acceptable range in the outcomes of optimization in terms of the obtained near-optimal configurations due to the nature of the new problem and its constraint-congested solution space. In addition, the results showed that the chosen configuration structure of a flow line that allows paralleling of machines proved to be capable of providing almost exactly the capacity needed when needed and thus achieving the capacity scalability requirements of RMS.

A thorough analysis of different cases of availability consideration (infinite buffer capacity and no buffer capacity) was performed and the results of a large number of runs were compared to the case of not considering machine availability. The analysis showed that considering availability affected the optimal configuration selection and increased the number of equipments (machines and removable modules) being used and accordingly the costs of the near-optimal configurations obtained. The case of no buffer capacity increased these costs drastically when compared to the case of infinite buffer capacity. The differences between both extreme cases deserve to prompt the investigation of the case of finite buffer capacity consideration and trigger an important question whether the use of buffer capacity is needed or not within this proposed RMS configuration structure. In answering such a question, the expenses of incurring buffer capacity in terms of space required and material handling equipment to be utilized have to be considered and accordingly the decision can be taken.

Another important conclusion to be extracted from the analysis is that the number of production stages of the near-optimal configurations is mainly affected by the functionality requirements of the system while the number of machines in parallel for these configurations is mainly affected by the capacity requirements and availability considerations of the system. Therefore, it can be deduced that for a manufacturing system to be capable of providing the capacity and functionality needed when it is



needed, it has to have flexibility in its length, expressed by the number of production stages, and its width, expressed by the number of machines in parallel.

Finally, it is worth noting that this chapter concludes the first stage of the developed RMS Configuration Selection Approach. The optimization model developed provides the second stage of the approach with a predefined number of alternative near-optimal configurations, based on capital cost and system availability, for each anticipated demand scenario (DS) at each configuration period (CP) within the planning horizon of the system. The main reason for having more than one alternative for each DS is to provide the second stage of the procedure with a variety of good alternatives to choose from in order to achieve near-optimal level of reconfiguration smoothness, which is the main objective of the second stage of the procedure. Appendix E provides a sample of the results report of one full run as generated by the tool developed for the overall approach (RMS-Configurator), the first part of which represents the results of the first stage.

The next two chapters provide a detailed description of the second stage of the approach and report its overall outcome results.

## 6. RECONFIGURATION SMOOTHNESS

This chapter introduces the concept of “*Reconfiguration Smoothness*” to measure and guide the effort of reconfiguration based on the work done by Youssef and H. ElMaraghy (2006a). The chapter starts by providing a detailed description of a Reconfiguration Smoothness (RS) metric that was developed to provide a relative indication of the effort, time and cost required to convert the system from one configuration to another. This metric is composed of three components representing different levels of reconfiguration, namely; Market-level Reconfiguration Smoothness (TRS), System-level Reconfiguration Smoothness (SRS) and Machine-level Reconfiguration Smoothness (MRS). Rules are introduced to help determine the exact locations for the different production stages within the flow line configuration structure and accordingly guide the development of execution plans for system-level reconfiguration, which is called “*Reconfiguration Planning*”. These plans as well as the stage locations selected help reduce the physical effort of reconfiguring the system. A procedure is, then, presented for automatically developing detailed step-by-step execution plans for reconfiguration based on the reconfiguration planning rules. This prevents human interventions based on subjective decisions. An example is provided for demonstrating the use of both the metric and the rules followed by their application to a case study. The chapter concludes with sensitivity analysis and a discussion of results.

### 6.1 Reconfiguration Smoothness (RS) Metric

The anticipated reconfiguration process has to be considered in the process of selection of RMS configurations. The term “*Reconfiguration Smoothness*”, introduced by Youssef and H. ElMaraghy (2006a), reflects the easiness and smoothness of transforming the system from one configuration to the next. This is essential to evaluate in order to be able to select system configurations that not only satisfy the current demand requirements but also will be easily and smoothly reconfigured to satisfy the anticipated demand requirements in future periods within the planning horizon of the manufacturing systems.

A metric was developed in order to measure the level of reconfiguration smoothness (RS) (Youssef and H. ElMaraghy 2006a). This metric gives a relative measure of the expected cost, time and effort required to change from one configuration to another rather than estimating the exact time and cost of the reconfiguration process, which is difficult to evaluate. This metric will be used to evaluate the degree of closeness between any two possible consecutive configurations.

The purpose of evaluating the reconfiguration smoothness is to compare different candidate feasible configurations for future CPs based on the easiness of reconfiguration from a current configuration. These RS evaluations will be provided to the higher-level management to support their decision-making regarding the configuration selection.

The developed reconfiguration smoothness metric is composed of three components representing different levels of reconfiguration, namely; Market-level Reconfiguration Smoothness (TRS), System-level Reconfiguration Smoothness (SRS) and Machine-level Reconfiguration Smoothness (MRS). Accordingly, RS between configurations  $C_1$  and  $C_2$  is defined as follows:

$$RS = \alpha TRS + \beta SRS + \gamma MRS, \quad (6.1)$$

where  $\alpha + \beta + \gamma = 1$  and the three components TRS, SRS and MRS all lie between 0 and 1 to make the value of RS lie between 0 and 1. When the two configurations  $C_1$  and  $C_2$  are identical, RS becomes 0.

It is recommended that  $\beta > \gamma > \alpha$  as these weights reflect the relative amount of cost, time and effort required for performing the activities corresponding to the three components associated with any reconfiguration process. Generally, the system-level activities are the most expensive as they mostly involve hard-type reconfiguration activities e.g. adding/removing of machines/stations. This is followed by the machine-level activities, which involve both hard-type reconfiguration activities e.g. adding/removing of machine modules and soft-type reconfiguration activities e.g. changing of operation clusters setup assignments. This is followed by the market-level activities, which mostly involve soft-type reconfiguration activities e.g. buying/selling of machines/stations and/or machine modules. H. ElMaraghy (2002, 2006) provides

examples of both hard and soft types of reconfiguration activities. The following sections describe the three components TRS, SRS and MRS in detail.

### 6.1.1 Market-Level Reconfiguration Smoothness (TRS)

The market-level reconfiguration smoothness (TRS) reflects the cost, time and effort required to perform market-level activities that are associated with the reconfiguration process. These types of activities are performed outside the boundaries of the manufacturing system and are mostly soft-type reconfiguration activities. They include marketing activities, bidding activities, financial activities, logistic activities, shipping activities and all other activities that are associated with: a) buying/renting of new machines/stations and/or machine modules that are required by the new configuration ( $C_2$ ) and b) selling/returning of machines/stations and/or machine modules that were utilized by the previous configuration ( $C_1$ ) and are no longer required by the new configuration ( $C_2$ ).

TRS is divided into two components namely;  $TRS_m$  representing changes related to use of machines/stations and  $TRS_d$  representing changes related to use of machine modules. Therefore, TRS is defined as follows:

$$TRS = \varepsilon TRS_m + (1 - \varepsilon) TRS_d, \quad (6.2)$$

where  $\varepsilon$  lies in  $[0 \ 1]$  and,

$$\begin{aligned} TRS_m &= \delta \frac{\text{Number of Added Machines}}{\text{Total Number of Machines}} + (1 - \delta) \frac{\text{Number of Removed Machines}}{\text{Total Number of Machines}} \\ &= \delta \frac{\sum_{Mi \in M_2 - M_1} Mi}{\sum_{Mi \in M_1 \cup M_2} Mi} + (1 - \delta) \frac{\sum_{Mi \in M_1 - M_2} Mi}{\sum_{Mi \in M_1 \cup M_2} Mi}, \end{aligned} \quad (6.3)$$

$$\begin{aligned} TRS_d &= \delta \frac{\text{Number of Added Machine Modules}}{\text{Total Number of Machine Modules}} + (1 - \delta) \frac{\text{Number of Removed Machine Modules}}{\text{Total Number of Machine Modules}} \\ &= \delta \frac{\sum_{Mi \in M_1 \cap M_2} MCi_{j2-j1}}{\sum_{Mi \in M_1 \cap M_2} (MCi_{j1} + MCi_{j2-j1})} + (1 - \delta) \frac{\sum_{Mi \in M_1 \cap M_2} MCi_{j1-j2}}{\sum_{Mi \in M_1 \cap M_2} (MCi_{j1} + MCi_{j2-j1})}, \end{aligned} \quad (6.4)$$

where  $M_1$  and  $M_2$  are the sets of machines/stations that are utilized in configurations  $C_1$  and  $C_2$  respectively and  $\delta$  lies in  $[0 \ 1]$ .

It is recommended that  $\varepsilon > 0.5$  because the TRS activities associated with machines/stations are more cost, time and effort consuming than those associated with machine modules. It is recommended as well that  $\delta > 0.5$  because, generally, the activities associated with buying/renting are more cost, time and effort consuming than those associated with selling/returning of either machines/stations or machine modules.

### 6.1.2 System-Level Reconfiguration Smoothness (SRS)

The system-level reconfiguration smoothness (SRS) reflects the cost, time and effort required to perform system-level activities that are associated with the reconfiguration process. These types of activities are performed within the boundaries of the manufacturing system but at a level higher than machines. They mostly include hard-type reconfiguration activities like installation/un-installation of machines/stations and/or whole stages, installation/un-installation of material handling equipment corresponding to installed/un-installed stages, changing the number of material handling flow paths between stages and relocating of material handling equipment according to changes in stage locations. In addition, they include soft-type reconfiguration activities like increasing/decreasing the number of assigned operators.

All these activities, hard and soft, are included in addition to all other activities that are associated with: a) adding/removing of machines/stations and/or whole stages to/from the system, b) moving (relocating) of machines/stations and/or whole stages from their original location to other locations within the system and c) increasing/decreasing number of material flow paths between stages which is a function of the number of machines/stations in each stage.

SRS is divided into three components namely;  $SRS_s$  representing changes related to stages,  $SRS_m$  representing changes related to machines/stations and  $SRS_f$  representing changes related to number of material flow paths. Therefore, SRS is defined as follows:

$$SRS = \phi SRS_s + \varphi SRS_m + \lambda SRS_f, \quad (6.5)$$

where  $\phi + \varphi + \lambda = 1$  and,

$$\begin{aligned}
SRS_s &= \pi \frac{\text{Number of Installed Stage Types}}{\text{Total Number of Stage Types}} + (1 - \pi) \frac{\text{Number of Un - Installed Stage Types}}{\text{Total Number of Stage Types}} \\
&= \pi \frac{\sum_{S_i \in S_2 - S_1} S_i + \sum_{S_i \in S_m} S_i}{\sum_{S_i \in S_1 \cup S_2} S_i} + (1 - \pi) \frac{\sum_{S_i \in S_1 - S_2} S_i + \sum_{S_i \in S_m} S_i}{\sum_{S_i \in S_1 \cup S_2} S_i}, \tag{6.6}
\end{aligned}$$

$$\begin{aligned}
SRS_m &= \pi \frac{\text{Number of Installed Machines}}{\text{Total Number of Machines}} + (1 - \pi) \frac{\text{Number of Un - Installed Machines}}{\text{Total Number of Machines}} \\
&= \pi \frac{\sum_{M_i \in M_2 - M_1} M_i + \sum_{M_i \in M_m} M_i}{\sum_{M_i \in M_1 \cup M_2} M_i} + (1 - \pi) \frac{\sum_{M_i \in M_1 - M_2} M_i + \sum_{M_i \in M_m} M_i}{\sum_{M_i \in M_1 \cup M_2} M_i}, \tag{6.7}
\end{aligned}$$

$$\begin{aligned}
SRS_f &= \theta \frac{\text{Number of Added Material Flow Paths}}{\text{Total Number of Material Flow Paths}} \\
&\quad + (1 - \theta) \frac{\text{Number of Removed Material Flow Paths}}{\text{Total Number of Material Flow Paths}} \\
&= \theta \frac{\sum_{i=1}^{NS_2-1} \max[(NM_{i_2} * NM_{i+1_2} - NM_{i_1} * NM_{i+1_1}), 0]}{\sum_{i=1}^{\max(NS_1, NS_2)-1} \max[(NM_{i_1} * NM_{i+1_1}), (NM_{i_2} * NM_{i+1_2})]} \\
&\quad + (1 - \theta) \frac{\sum_{i=1}^{NS_1-1} \max[(NM_{i_1} * NM_{i+1_1} - NM_{i_2} * NM_{i+1_2}), 0]}{\sum_{i=1}^{\max(NS_1, NS_2)-1} \max[(NM_{i_1} * NM_{i+1_1}), (NM_{i_2} * NM_{i+1_2})]}, \tag{6.8}
\end{aligned}$$

where  $S_1$  and  $S_2$  are the sets of stage types that are utilized in configurations  $C_1$  and  $C_2$  respectively,  $S_m$  is the set of stages that are moved (relocated) in reconfiguration from configuration  $C_1$  to configuration  $C_2$ ,  $S_i$  is any stage type  $i$ ,  $M_m$  is the set of machines/stations that are moved (relocated) in reconfiguration from configuration  $C_1$  to configuration  $C_2$ ,  $NS_1$  and  $NS_2$  are the numbers of stages used in configurations  $C_1$  and  $C_2$  respectively,  $NM_{i_1}$  and  $NM_{i_2}$  are the numbers of machines in stage  $i$  in configurations  $C_1$  and  $C_2$  respectively and the weights  $\pi, \nu$  &  $\theta$  lie in  $[0 \ 1]$ .

It is recommended that  $\phi > \varphi > \lambda$  as these weights reflect the relative amount of cost, time and effort for performing activities corresponding to the four SRS components. Generally, activities associated with changes related to stages are the most expensive with regards to time, cost and effort as they involve both hard-type reconfiguration concerning the type of material handling equipment used and soft-type reconfiguration concerning the number of operators assigned. This is followed by the activities associated

with changes related to machines/stations, which is followed by activities associated with changes in material flow paths.

It is recommended that  $\pi > 0.5$  because, generally, the activities associated with adding a new/relocated stage or machine are more cost, time and effort consuming than those associated with removing a new/relocated stage or machine because adding involves calibration, setup and other ramp up activities. It is recommended, as well that  $\theta > 0.5$  because increasing the number of flow paths between stages is obviously more complicated with regards to material handling design and installation than decreasing them.

From the above analysis, regarding the system-level reconfiguration smoothness (SRS), there is a need for information about the location of each stage in each of the two consecutive configurations and the number of machines or whole stages that have to be moved/relocated in order to reconfigure from configuration  $C_1$  to configuration  $C_2$ . Such information is available if a specific reconfiguration execution plan is known. Therefore, some rules should be set for deciding how the reconfiguration will take place at the system-level. Section 6.2 presents some rules that have been developed to guide reconfiguration planning and a procedure for the automatic implementation of these rules.

### **6.1.3 Machine-Level Reconfiguration Smoothness (MRS)**

The machine-level reconfiguration smoothness (MRS) reflects the cost, time and effort required to perform machine-level activities that are associated with the reconfiguration process. These types of activities are performed inside the boundaries of the manufacturing system and are all within the limits at the machine-level. They include hard-type reconfiguration activities like adding/removing of machine modules and/or machine fixtures to/from pre-existing machines/stations in the system. In addition, they include soft-type reconfiguration activities like adding/removing operation clusters setup assignments to/from pre-existing machines/stations with same machine configurations and accordingly changing of setups and control systems for these machines/stations.



All these activities, hard and soft, are included in addition to all other activities that are associated with: a) adding/removing of machine modules due to reconfiguration of machines/stations that will remain in the system and b) adding/removing of operation cluster assignments to/from machines/stations that will remain in the system keeping their same configurations. MRS is divided into two components namely;  $MRS_d$  representing changes related to utilization of machine modules (changes in machine configurations) and  $MRS_o$  representing changes related to operation cluster assignments. Therefore, MRS is defined as follows:

$$MRS = \nu MRS_d + (1 - \nu) MRS_o, \quad (6.9)$$

where  $\nu$  lies in  $[0 \ 1]$  and,

$$\begin{aligned} MRS_d &= \sigma \frac{\text{Number of Added Machine Modules}}{\text{Total Number of Machine Modules}} + (1 - \sigma) \frac{\text{Number of Removed Machine Modules}}{\text{Total Number of Machine Modules}} \quad (6.10) \\ &= \sigma \frac{\sum_{Mi \in M_1 \cap M_2} MCi_{j2-j1}}{\sum_{Mi \in M_1 \cap M_2} (MCi_{j1} + MCi_{j2-j1})} + (1 - \sigma) \frac{\sum_{Mi \in M_1 \cap M_2} MCi_{j1-j2}}{\sum_{Mi \in M_1 \cap M_2} (MCi_{j1} + MCi_{j2-j1})}, \end{aligned}$$

$$\begin{aligned} MRS_o &= \sigma \frac{\text{Number of OS Assignments Added to Machines Keeping their Configurations}}{\text{Total Number of OS Assignments for Machines Keeping their Configurations}} \\ &\quad + (1 - \sigma) \frac{\text{Number of OS Assignments Removed from Machines Keeping their Configurations}}{\text{Total Number of OS Assignments for Machines Keeping their Configurations}} \quad (6.11) \\ &= \sigma \frac{\sum_{OSj \in OS_{i,k}(2) - OS_{i,k}(1) \& Mi \in M_1 \cap M_2} OSj}{\sum_{OSj \in OS_{i,k}(1) \cup OS_{i,k}(2) \& Mi \in M_1 \cap M_2} OSj} \\ &\quad + (1 - \sigma) \frac{\sum_{OSj \in OS_{i,k}(1) - OS_{i,k}(2) \& Mi \in M_1 \cap M_2} OSj}{\sum_{OSj \in OS_{i,k}(1) \cup OS_{i,k}(2) \& Mi \in M_1 \cap M_2} OSj}, \end{aligned}$$

where  $OS_{i,k}(1)$  and  $OS_{i,k}(2)$  are the operation clusters setups that are assigned to machine/station  $i$  with machine configuration  $k$  in configurations  $C_1$  and  $C_2$  respectively and  $\sigma$  lies in  $[0 \ 1]$ .

It is recommended that  $\nu > 0.5$  because the MRS activities associated with machine reconfiguration (adding/removing of modules) already encompass the activities associated with changes in operation cluster assignments and more. It is recommended, as well, that  $\sigma > 0.5$  because, generally, the activities associated with adding either machine modules or operation cluster assignments are more cost, time and effort

consuming than those associated with removing of either machine modules or operation cluster assignments.

Generally, the weights to be assigned for the various metric components are best left for the user, e.g. the facilities planning engineer, to determine according to the situation. This is due to the fact that the relative influence, on reconfiguration smoothness, of the different types and levels of reconfiguration activities, expressed by these weights, is case-based and cannot be generalized to accommodate all practical situations. It is also function of the infrastructure setup in the facility and the degree of modularity of the controllers being used on both the system-level and the machine-level. For example, it is easier to relocate a machine in a facility where the electric supply infrastructure is modular. However, the suggested recommendations provide guidelines for determining values of these weights for the majority of situations.

## **6.2 Reconfiguration Planning**

### **6.2.1 Reconfiguration Planning Rules**

There are normally different alternative plans for reconfiguring the manufacturing system. There is a need for some rules to help plan the reconfiguration process and, accordingly, determine some parameters required to fully define the reconfiguration smoothness metric (RS). In addition, these rules will help the decision-makers with regards to the reconfiguration process and how it can be pursued. Minimizing the effort of reconfiguration must be taken into consideration in developing these rules. The following are the rules developed for reconfiguration planning in the order of application to break possible ties:

- Maximize the number of stage types that keep their locations.
- Maximize the number of machines that keep their locations.
- Minimize the number of empty stage locations between consecutive stages.
- Maximize the number of machines that keep their configurations.
- Maximize the number of machines that keep their operation clusters setup assignment.

The first two rules are concerned with minimizing the physical movement/relocation of stage types and machines respectively, which are considered system-level reconfiguration activities (the most expensive reconfiguration activities). The space limitations in terms of the available stage locations have to be considered when applying the first rule. The third rule, on the other hand, is concerned with minimizing the material handling effort by minimizing the distances between consecutive stages. Finally, the fourth and fifth rules are concerned with minimizing the machine-level reconfiguration activities whether it is hard (machine reconfiguration) or soft (change in operation clusters setup assignments).

## **6.2.2 Reconfiguration planning Procedure**

A procedure was developed, based on the reconfiguration planning rules just presented, in order to automatically determine the exact locations for the different production stages of the second configuration ( $C_2$ ) and accordingly develop detailed step-by-step execution plans for reconfiguring the system from an original configuration ( $C_1$ ) to the second configuration ( $C_2$ ). This prevents human interventions based on subjective decisions and helps in the automatic evaluation of the RS metric. The procedure has two stages, representing the above-mentioned two goals, that are described in the next two sections (6.2.2.1-6.2.2.2).

### **6.2.2.1 Stage I: Determination of Exact Stage Locations for $C_2$**

This stage of the reconfiguration planning procedure helps in determining the exact location of the different production stages in the second configuration ( $C_2$ ) based on the reconfiguration planning rules introduced. This stage is composed of four steps:

1. Generate all the possible sets of distributions of stage locations for the production stages of the second configuration over the available stage locations of the system within the allowable limit of configuration length (maximum number of stages in the configuration).
2. Compare each of the sets generated in Step 1 with the original configuration to determine and store the following information:
  - a. The number of stage types that keep their locations.
  - b. The number of machines that keep their locations.

- c. The number of empty stage locations between consecutive stages.
  - d. The number of machines that keep their configurations from those that keep their locations.
  - e. The number of machines that keep their operation clusters setup assignment from those that keep their configurations.
3. Evaluate each of the generated sets, as a function of the values obtained in Step 2, in a way that gives preference in comparison to the values in the order of priority of the reconfiguration planning rules, the same as the order in step 2.
  4. Compare the values obtained in Step 3 for each of the sets and choose the set of locations with the highest value.

#### 6.2.2.2 Stage II: Development of Reconfiguration Execution Plans

This stage of the reconfiguration planning procedure is used for the development of detailed step-by-step execution plans for system-level reconfiguration of the system from an original configuration ( $C_1$ ) to a second configuration ( $C_2$ ) based on the reconfiguration planning rules introduced and the exact stage locations determined. This prevents human interventions that are based on subjective decisions in executing the reconfiguration activities and helps in the automatic evaluation of the RS metric. This stage of the procedure is composed of five main steps that are function of the type of reconfiguration activities being performed. The steps are ordered in a way that preserves the same order of priority of the reconfiguration planning rules seeking the reduction in the effort of reconfiguration. In addition, the detailed step-by-step reconfiguration execution plans developed at the end of this procedure provides a practically natural sequence of reconfiguration steps from an implementation point of view. The main steps in this stage of the procedure are as follows:

1. *Stages that keep their locations in the system.* For each stage in the second configuration, if its stage type (type of machine in the stage) is the same as the stage type corresponding to the same location in the original configuration, then:
  - a. Mark this stage in the original configuration as keeping its location and mark the designated stage of the second configuration as already assigned.

- b. Determine the minimum of the numbers of machines allocated for this stage location in both the original and the second configuration and store it as the number of machines of this type that keep this specific location.
  - c. Use the number obtained in the previous step to reduce and accordingly keep record of the number of remaining machines in this stage location of the original configuration and the number of machines still to be allocated in this designated stage location of the second configuration.
  - d. If the number of remaining machines in this stage location of the original configuration is reduced to nil, then mark the stage as fully emptied.
  - e. If the number of machines still to be allocated in this designated stage location of the second configuration is reduced to nil, then mark the stage as fully equipped.
2. *Stages that are relocated from their original locations to other locations in the system.* For each stage in the second configuration, if it has not been assigned or is not already fully equipped, then:
- a. Search for any stages in the original configuration that have the same stage type and are not marked as fully emptied.
  - b. Evaluate each of the candidate stages obtained in the previous step, if any was found, and select the stage with the machine configuration that is closest to the one in the designated stage of the second configuration.
  - c. If the selected stage in the original configuration was not marked earlier, as keeping its location or already relocated to any other stage in the second configuration, then mark it as relocated from its stage location in the original configuration to this designated stage location in the second configuration and mark this designated stage of the second configuration as already assigned.
  - d. Determine the minimum of the number of machines remaining in the selected stage of the original configuration and the number of machines still to be allocated in the designated stage of the second configuration and store it as the number of machines of this type that are relocated from their

- stage location in the original configuration to this designated stage location in the second configuration.
- e. Use the number obtained in the previous step to reduce and accordingly keep record of the number of remaining machines in this stage location of the original configuration and the number of machines still to be allocated in this designated stage location of the second configuration.
  - f. If the number of remaining machines in this stage location of the original configuration is reduced to nil, then mark the stage as fully emptied.
  - g. If the number machine still to be allocated in this designated stage location of the second configuration is reduced to nil, then mark the stage as fully equipped.
3. *Stages in the second configuration that get additional supply of machines from other stage locations of the original configuration.* For each stage in the second configuration, if it is not already fully equipped, then:
- a. Search for any stages in the original configuration that have the same stage type and are not marked as fully emptied.
  - b. Evaluate each of the candidate stages obtained in the previous step, if any was found, and select the one with the machine configuration that is closest to the one in the designated stage of the second configuration.
  - c. Determine the minimum of the number of machines remaining in the selected stage of the original configuration and the number of machines still to be allocated in the designated stage of the second configuration and store it as the number of machines of this type that are relocated from their stage location in the original configuration to this designated stage location in the second configuration.
  - d. Use the number obtained in the previous step to reduce and accordingly keep record of the number of remaining machines in this stage location of the original configuration and the number of machines still to be allocated in this designated stage location of the second configuration.
  - e. If the number of remaining machines in this stage location of the original configuration is reduced to nil, then mark the stage as fully emptied.

- f. If the number machine still to be allocated in this designated stage location of the second configuration is reduced to nil, then mark the stage as fully equipped.
4. *Stages from the original configuration that have extra machines to be removed from the system (offered outside the system) as they are not needed by the system.* For each stage in the original configuration, if it is not marked as fully emptied, then:
- a. Mark the remaining machines in this stage as being not needed by the system and accordingly to be removed from the system (offered outside the system).
  - b. If this stage of the original configuration was not marked earlier, as keeping its location or already relocated to any other stage in the second configuration, then mark it as removed from the system.
5. *Stages in the second configuration that still need to get additional supply of new machines to be added to the system (supplied from outside the system).* For each stage in the second configuration, if it not marked as fully equipped:
- a. Mark the number of machines still to be allocated in this stage as new machines to be added to the system (supplied from outside the system).
  - b. If this stage of the second configuration was not marked earlier as already assigned, then mark it as a new stage added to the system (supplied from outside the system).

Accordingly, the following information is available to provide an ordered step-by-step execution plan of reconfiguring the system from its original configuration to the second configuration:

1. Stages information:
  - a. The stage types in specific locations of the original configuration that will keep their locations in the system to be used in the second configuration.
  - b. The stage types in specific locations of the original configuration that will be totally removed from the system as they are not needed by the second configuration.



- c. The stage types in specific locations of the original configuration that will be relocated to different locations in the system to be used in the second configuration.
  - d. The new stage types to be added to the system in specific locations to be used in the second configuration.
2. Machines information:
- a. The type and number of machines in specific locations of the original configuration that will keep their locations in the system to be used in the second configuration.
  - b. The type and number of machines in specific locations of the original configuration that will be totally removed from the system as they are not needed by the second configuration.
  - c. The type and number of machines in specific locations of the original configuration that will be relocated to different locations in the system to be used in the second configuration.
  - d. The type and number of new machines to be added to the system in specific locations to be used in the second configuration.

### 6.3 Example on Reconfiguration Planning and RS Evaluation

An example is presented to demonstrate the concept of reconfiguration planning, implementation of the developed rules and the use of the reconfiguration smoothness metric.

Consider the system reconfiguration example presented earlier in Figure 1.4. First, the reconfiguration planning rules are applied to decide the steps of reconfiguration from  $C_1$  to  $C_2$ . The first rule aims at maximizing the number of stage types that keep their locations. Stage type M6 may be kept in its location (SL3) and stage type M3 moved from SL4 to the next location (SL5) in order to allow stage type M2 to be placed in location SL4. Alternatively, stage type M3 may be kept in SL4 and stage type M6 moved from SL3 to the prior location (SL2) in order to allow stage type M2 to be placed in location SL3. Figure 6.1 demonstrates two alternative reconfiguration possibilities. The

application of the first rule is not sufficient for differentiating the two because for both, only one stage type will keep its location. Therefore, the second rule is used. This rule aims at maximizing the number of machines that keep their locations. Here, the first alternative is better because it means keeping two machines of type M6 in their location while the other alternative means keeping only one machine of type M3 in its location. Therefore the first reconfiguration alternative is chosen as shown in Figure 6.1.

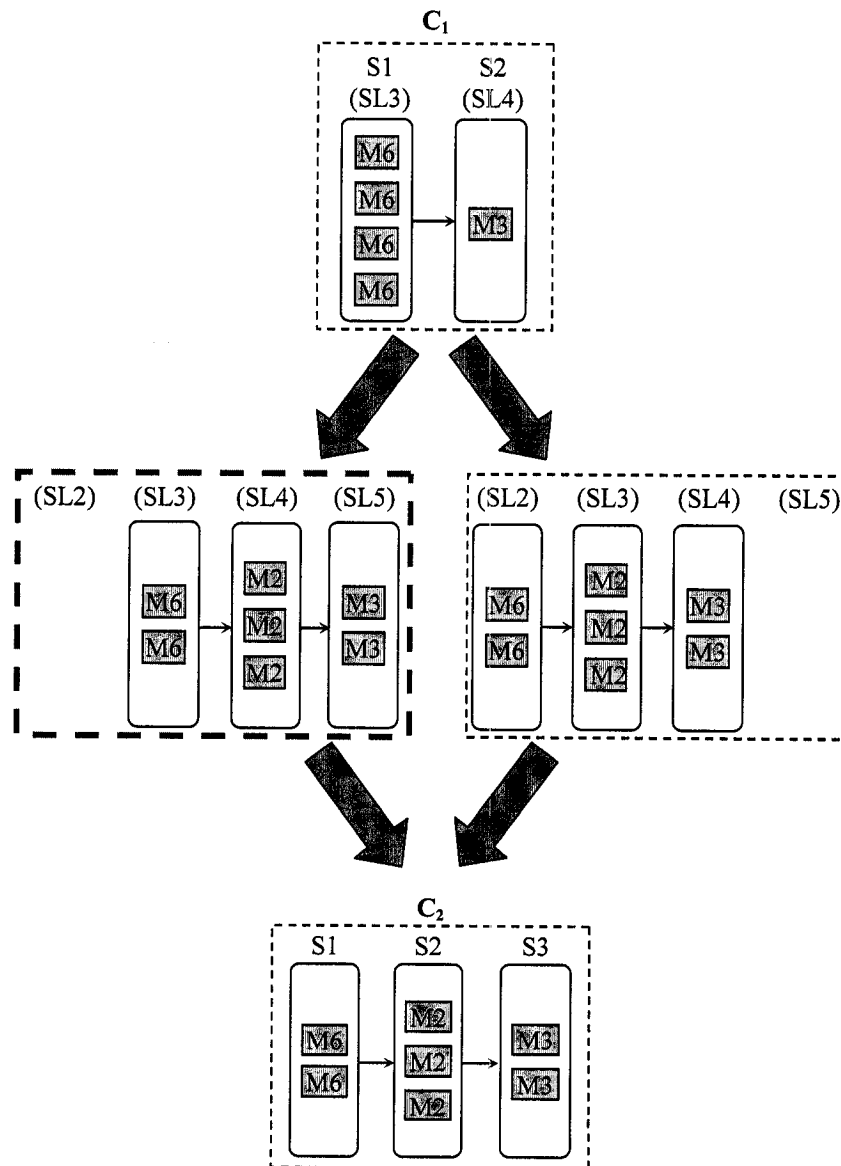

Figure (6.1) Alternative reconfiguration plans.

Therefore, the step-by-step action plan for reconfiguration from  $C_1$  to  $C_2$  is as follows:

I) Stages:

1. Stage of type M6 located in SL3 will keep its location in the system.
2. Stage of type M3 located in SL4 will be relocated to SL5 of the system.
3. A new stage of type M2 will be added to SL4 of the system.

II) Machines:

1. 2 M6 machines located in SL3 will keep their location in the system.
2. 2 M6 machines located in SL3 will be totally removed from the system.
3. 1 M3 machine located in SL4 will be relocated to SL5 of the system.
4. 3 new M2 machines will be added to SL4 of the system.
5. 1 new M3 machine will be added to SL5 of the system.

Now, the reconfiguration smoothness (RS) between  $C_1$  and  $C_2$  can be evaluated, according to the first reconfiguration alternative, using the metric. In doing that, values were chosen for the different metric weights according to the suggested recommendations.

#### RS Evaluation of ( $C_1$ - $C_2$ ) for the First Reconfiguration Alternative:

- Market-level reconfiguration smoothness (TRS) [Eqs. (6.2)-(6.4)]:

$$TRS_m = \frac{2}{3} \left( \frac{4}{9} \right) + \frac{1}{3} \left( \frac{2}{9} \right) = \frac{10}{27}, \quad TRS_d = \frac{2}{3} \left( \frac{1+2(1)}{(3+1)+2(1+1)} \right) + \frac{1}{3} \left( \frac{0}{(3+1)+2(1+1)} \right) = \frac{1}{4}$$

$$\therefore TRS = \frac{2}{3} \left( \frac{10}{27} \right) + \frac{1}{3} \left( \frac{1}{4} \right) = \frac{107}{324} = 0.3302$$

- System-level reconfiguration smoothness (SRS) [Eqs. (6.5)-(6.8)]:

$$SRS_s = \frac{2}{3} \left( \frac{1+1}{3} \right) + \frac{1}{3} \left( \frac{0+1}{3} \right) = \frac{5}{9}, \quad SRS_m = \frac{2}{3} \left( \frac{4+1}{9} \right) + \frac{1}{3} \left( \frac{2+1}{9} \right) = \frac{13}{27},$$

$$SRS_f = \frac{2}{3} \left( \frac{(6-4)+(6-0)}{6+6} \right) + \frac{1}{3} \left( \frac{0}{6+6} \right) = \frac{4}{9}$$

$$\therefore SRS = \frac{3}{6} \left( \frac{5}{9} \right) + \frac{2}{6} \left( \frac{13}{27} \right) + \frac{1}{6} \left( \frac{4}{9} \right) = \frac{83}{162} = 0.5123$$

- Machine-level reconfiguration smoothness (MRS) [Eqs. (6.9)-(6.11)]:

$$\text{MRS}_d = \frac{2}{3} \left( \frac{1+2(1)}{(3+1)+2(1+1)} \right) + \frac{1}{3} \left( \frac{0}{(3+1)+2(1+1)} \right) = \frac{1}{4}, \text{MRS}_o = 0$$

$$\therefore \text{MRS} = \frac{2}{3} \left( \frac{1}{4} \right) + \frac{1}{3} (0) = \frac{1}{6} = 0.1667$$

- Overall reconfiguration smoothness (RS) [Eq. (6.1)]:

$$\therefore \text{RS} = \frac{1}{6} \left( \frac{107}{324} \right) + \frac{3}{6} \left( \frac{83}{162} \right) + \frac{2}{6} \left( \frac{1}{6} \right) = 0.3668$$

The different components of the RS metric according to the second reconfiguration alternative can be evaluated and compared to the previous evaluations to validate the merits of using the reconfiguration planning rules.

#### RS Evaluation of (C<sub>1</sub>-C<sub>2</sub>) for the Second Reconfiguration Alternative:

- Market-level reconfiguration smoothness (TRS) [Eqs. (6.2)-(6.4)]:

$$\text{TRS}_m = \frac{2}{3} \left( \frac{4}{9} \right) + \frac{1}{3} \left( \frac{2}{9} \right) = \frac{10}{27}, \text{TRS}_d = \frac{2}{3} \left( \frac{1+2(1)}{(3+1)+2(1+1)} \right) + \frac{1}{3} \left( \frac{0}{(3+1)+2(1+1)} \right) = \frac{1}{4}$$

$$\therefore \text{TRS} = \frac{2}{3} \left( \frac{10}{27} \right) + \frac{1}{3} \left( \frac{1}{4} \right) = \frac{107}{324} = 0.3302$$

- System-level reconfiguration smoothness (SRS) [Eqs. (6.5)-(6.8)]:

$$\text{SRS}_s = \frac{2}{3} \left( \frac{1+1}{3} \right) + \frac{1}{3} \left( \frac{0+1}{3} \right) = \frac{5}{9}, \text{SRS}_m = \frac{2}{3} \left( \frac{4+2}{9} \right) + \frac{1}{3} \left( \frac{2+2}{9} \right) = \frac{16}{27},$$

$$\text{SRS}_f = \frac{2}{3} \left( \frac{(6-4)+(6-0)}{6+6} \right) + \frac{1}{3} \left( \frac{0}{6+6} \right) = \frac{4}{9}$$

$$\therefore \text{SRS} = \frac{3}{6} \left( \frac{5}{9} \right) + \frac{2}{6} \left( \frac{16}{27} \right) + \frac{1}{6} \left( \frac{4}{9} \right) = \frac{89}{162} = 0.5494$$

- Machine-level reconfiguration smoothness (MRS) [Eqs. (6.9)-(6.11)]:

$$\text{MRS}_d = \frac{2}{3} \left( \frac{1+2(1)}{(3+1)+2(1+1)} \right) + \frac{1}{3} \left( \frac{0}{(3+1)+2(1+1)} \right) = \frac{1}{4}, \text{MRS}_o = 0$$

$$\therefore \text{MRS} = \frac{2}{3} \left( \frac{1}{4} \right) + \frac{1}{3} (0) = \frac{1}{6} = 0.1667$$

- Overall reconfiguration smoothness (RS) [Eq. (3.1)]:

$$\therefore RS = \frac{1}{6} \left( \frac{107}{324} \right) + \frac{3}{6} \left( \frac{89}{162} \right) + \frac{2}{6} \left( \frac{1}{6} \right) = 0.3853$$

The results of evaluating the RS metric for both alternatives show the superiority of the first reconfiguration alternative. Although, both alternatives gave the same values for the TRS and MRS components, as expected, the values of the SRS component caused the distinction between both alternatives since the first alternative leads to fewer machine relocations. This illustrates the merits of the developed reconfiguration planning rules that arrived at the same decision of choosing the first alternative.

## 6.4 Case Study

In order to demonstrate the use of the developed RS metric and perform sensitivity analysis to show the effect of changing different metric parameters, a case study is presented based on the two example parts, ANC-90 and ANC-101, and the available/obtainable resources previously described in Section 4.5.1 of Chapter 4.

### 6.4.1 Case Description

Consider the case of having a first configuration period (CP1) where part ANC-90 (part A) is to be produced with a rate of 120 parts/hour followed by a second configuration period (CP2) where part ANC-101 (part B) is to be produced with a rate of 180 parts/hour. Figure 6.2 demonstrates two possible reconfiguration scenarios from a first configuration ( $C_1$ ) capable of satisfying the demand requirements of CP1 (part A at 120 parts/hour) to two possible candidates for a second configuration ( $C_{21}$  and  $C_{22}$ ) that are capable of satisfying the requirements of CP2 (part B at 180 parts/hour). The developed RS metric will be evaluated for the two reconfiguration scenarios in order to choose the best in terms of reconfiguration smoothness.

The reconfiguration planning rules were, first, implemented to decide the reconfiguration steps from  $C_1$  to each of the two configurations  $C_{21}$  and  $C_{22}$ . Starting with the original configuration ( $C_1$ ), the first rule aims at maximizing the number of stage types that keep their locations. In both reconfiguration scenarios, all four stage types of

configuration ( $C_1$ ) can keep their locations so there is no need to proceed to the following rules. Therefore, the locations of the stages forming both configurations  $C_{21}$  and  $C_{22}$  will be as indicated in Figure 6.2. That means that there will be no stage or machine relocation in the reconfiguration process for both scenarios.

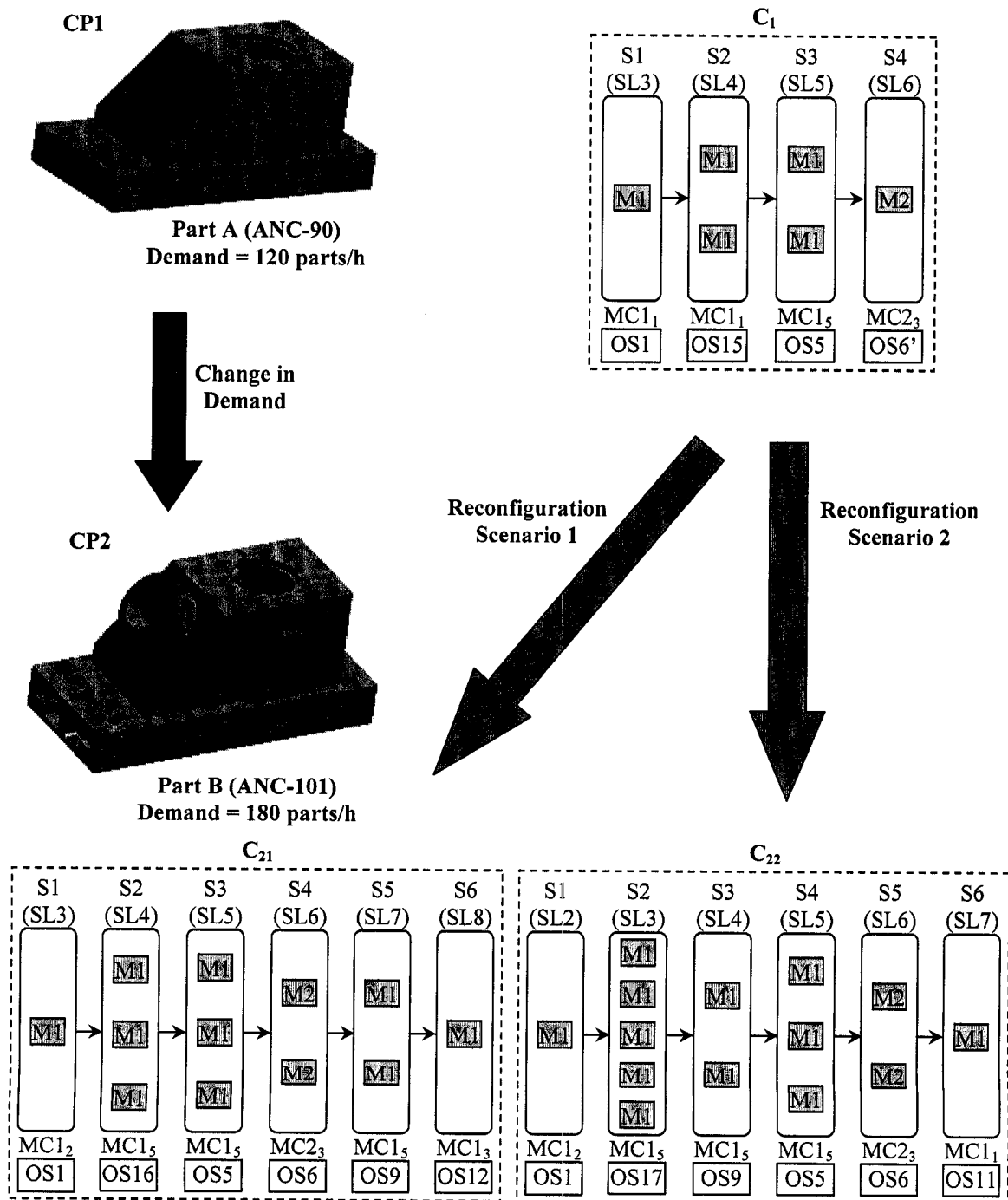

Figure (6.2) Two possible reconfiguration scenarios for the case study.

## 6.4.2 Reconfiguration Smoothness Evaluation Results

Now, the reconfiguration smoothness metric can be evaluated between configuration  $C_1$  and each of configurations  $C_{21}$  and  $C_{22}$ . Values for the different metric weights were chosen according to the suggested recommendations. Details of the RS evaluations and results are as follows:

### RS Evaluation for the First Reconfiguration Scenario ( $C_1$ - $C_{21}$ ):

- Market-level reconfiguration smoothness (TRS) [Eqs. (6.2)-(6.4)]:

$$\text{TRS}_m = \frac{2}{3} \left( \frac{6}{12} \right) + \frac{1}{3} \left( \frac{0}{12} \right) = \frac{1}{3},$$

$$\text{TRS}_d = \frac{2}{3} \left( \frac{1+2(1)+2(0)+0}{(3+1)+2(3+1)+2(4+0)+(3+0)} \right) + \frac{1}{3} \left( \frac{0}{(3+1)+2(3+1)+2(4+0)+(3+0)} \right) = \frac{2}{23}$$

$$\therefore \text{TRS} = \frac{2}{3} \left( \frac{1}{3} \right) + \frac{1}{3} \left( \frac{2}{23} \right) = \frac{52}{207} = 0.2512$$

- System-level reconfiguration smoothness (SRS) [Eqs. (6.5)-(6.8)]:

$$\text{SRS}_s = \frac{2}{3} \left( \frac{2+0}{6} \right) + \frac{1}{3} \left( \frac{0+0}{6} \right) = \frac{2}{9}, \quad \text{SRS}_m = \frac{2}{3} \left( \frac{6+0}{12} \right) + \frac{1}{3} \left( \frac{0+0}{12} \right) = \frac{1}{3},$$

$$\text{SRS}_f = \frac{2}{3} \left( \frac{(3-2)+(9-4)+(6-2)+(4-0)+(2-0)}{3+9+6+4+2} \right) + \frac{1}{3} \left( \frac{0+0+0}{3+9+6+4+2} \right) = \frac{4}{9}$$

$$\therefore \text{SRS} = \frac{3}{6} \left( \frac{2}{9} \right) + \frac{2}{6} \left( \frac{1}{3} \right) + \frac{1}{6} \left( \frac{4}{9} \right) = \frac{8}{27} = 0.2963$$

- Machine-level reconfiguration smoothness (MRS) [Eqs. (6.9)-(6.11)]:

$$\text{MRS}_d = \frac{2}{3} \left( \frac{1+2(1)+2(0)+0}{(3+1)+2(3+1)+2(4+0)+(3+0)} \right) + \frac{1}{3} \left( \frac{0}{(3+1)+2(3+1)+2(4+0)+(3+0)} \right) = \frac{2}{23},$$

$$\text{MRS}_o = \frac{2}{3} \left( \frac{1}{2(1)+2} \right) + \frac{1}{3} \left( \frac{1}{2(1)+2} \right) = \frac{1}{4}$$

$$\therefore \text{MRS} = \frac{2}{3} \left( \frac{2}{23} \right) + \frac{1}{3} \left( \frac{1}{4} \right) = \frac{13}{92} = 0.1413$$

- Overall reconfiguration smoothness (RS) [Eq. (6.1)]:

$$\therefore \text{RS}(C_1 - C_{21}) = \frac{1}{6} \left( \frac{52}{207} \right) + \frac{3}{6} \left( \frac{8}{27} \right) + \frac{2}{6} \left( \frac{13}{92} \right) = 0.2371$$



### RS Evaluation for the Second Reconfiguration Scenario (C<sub>1</sub>-C<sub>22</sub>):

- Market-level reconfiguration smoothness (TRS) [Eqs. (6.2)-(6.4)]:

$$\text{TRS}_m = \frac{2}{3} \left( \frac{8}{14} \right) + \frac{1}{3} \left( \frac{0}{14} \right) = \frac{8}{21},$$

$$\text{TRS}_d = \frac{2}{3} \left( \frac{1+2(1)+2(0)+0}{(3+1)+2(3+1)+2(4+0)+(3+0)} \right) + \frac{1}{3} \left( \frac{0}{(3+1)+2(3+1)+2(4+0)+(3+0)} \right) = \frac{2}{23}$$

$$\therefore \text{TRS} = \frac{2}{3} \left( \frac{8}{21} \right) + \frac{1}{3} \left( \frac{2}{23} \right) = \frac{410}{1449} = 0.2830$$

- System-level reconfiguration smoothness (SRS) [Eqs. (6.5)-(6.8)]:

$$\text{SRS}_s = \frac{2}{3} \left( \frac{2+0}{6} \right) + \frac{1}{3} \left( \frac{0+0}{6} \right) = \frac{2}{9}, \quad \text{SRS}_m = \frac{2}{3} \left( \frac{8+0}{14} \right) + \frac{1}{3} \left( \frac{0+0}{14} \right) = \frac{8}{21},$$

$$\text{SRS}_f = \frac{2}{3} \left( \frac{(5-2)+(10-4)+(6-2)+(6-0)+(2-0)}{5+10+6+6+2} \right) + \frac{1}{3} \left( \frac{0+0+0}{5+10+6+6+2} \right) = \frac{14}{29}$$

$$\therefore \text{SRS} = \frac{3}{6} \left( \frac{2}{9} \right) + \frac{2}{6} \left( \frac{8}{21} \right) + \frac{1}{6} \left( \frac{14}{29} \right) = \frac{194}{609} = 0.3186$$

- Machine-level reconfiguration smoothness (MRS) [Eqs. (6.9)-(6.11)]:

$$\text{MRS}_d = \frac{2}{3} \left( \frac{1+2(1)+2(0)+0}{(3+1)+2(3+1)+2(4+0)+(3+0)} \right) + \frac{1}{3} \left( \frac{0}{(3+1)+2(3+1)+2(4+0)+(3+0)} \right) = \frac{2}{23},$$

$$\text{MRS}_o = \frac{2}{3} \left( \frac{1}{2(1)+2} \right) + \frac{1}{3} \left( \frac{1}{2(1)+2} \right) = \frac{1}{4}$$

$$\therefore \text{MRS} = \frac{2}{3} \left( \frac{2}{23} \right) + \frac{1}{3} \left( \frac{1}{4} \right) = \frac{13}{92} = 0.1413$$

- Overall reconfiguration smoothness (RS) [Eq. (6.1)]:

$$\therefore \text{RS}(C_1 - C_{22}) = \frac{1}{6} \left( \frac{410}{1449} \right) + \frac{3}{6} \left( \frac{194}{609} \right) + \frac{2}{6} \left( \frac{13}{92} \right) = 0.2535$$

It is clear, from the RS results shown above, that the first reconfiguration scenario is smoother than the second one. For both scenarios, the machine-level reconfiguration was the smoothest (MRS has the least value) because the number of machine reconfiguration activities for machines remaining in the system was limited. In addition, the change in operation cluster assignments, for the machines that kept their configurations, was small.

The market-level reconfiguration was less smooth because there is a need for many new machines to be added to the system, which will lead to a large number of market-level activities (examples of these activities are mentioned in Section 6.1.1). However, the market-level activities involved with the machine modules are limited. The system-level reconfiguration smoothness was the worst in both scenarios because of the fact that there are changes with regards to addition of stages, addition of new machines and addition of more flow paths between different stages. Therefore, all the components involved in the SRS were influential on the final value of the SRS, which was the highest between the three levels.

Both scenarios were identical on the machine-level reconfiguration due to identical reconfiguration processes being involved for the machines remaining in the system. However, on both the market-level and the system-level, reconfiguration smoothness values for the first scenario were better than the second one due to the fact that the number of machines being added to the system was less in the first scenario.

In conclusion, the recommendations will be to proceed with the first reconfiguration scenario ( $C_1-C_{21}$ ) rather than the second one ( $C_1-C_{22}$ ), which will be more costly in time, effort and money. This means that, if the configuration selection decision at this stage is based only on reconfiguration smoothness, then configuration  $C_{21}$  will be selected for the second configuration period.

### 6.4.3 Sensitivity Analysis

The first reconfiguration scenario was used to perform sensitivity analysis in order to demonstrate the effect of changing the metric parameters on the different reconfiguration smoothness values; TRS, SRS, MRS and the total RS value. Figures 6.3-6.5 show the effect of changing the number of stages, the number of machines and the number of machine modules added to the system on these RS values respectively.

Figure 6.3 shows that the SRS is the only component that is sensitive to the change in the number of stages added to the system, which is expected since this type of change only affects the physical reconfiguration activities at the system level. Therefore, the

more weight assigned to the SRS in the RS metric (the higher the value of  $\alpha$ ), the more sensitive the overall RS value will be to the change in the number of stages.

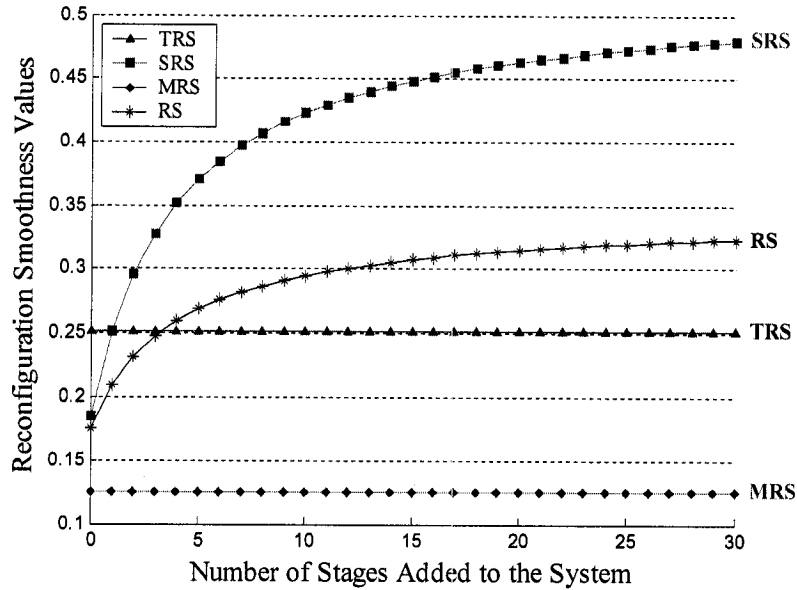

Figure (6.3) The effect of adding stages to the system on RS values.

Figure 6.4 shows that the TRS value is the most sensitive to the number of machines being added because this number is the major driver for most of the market-level activities associated with a reconfiguration process. The MRS, on the other hand, is insensitive to the number of added machines, as it has no effect on the reconfiguration activities performed at the machine-level.

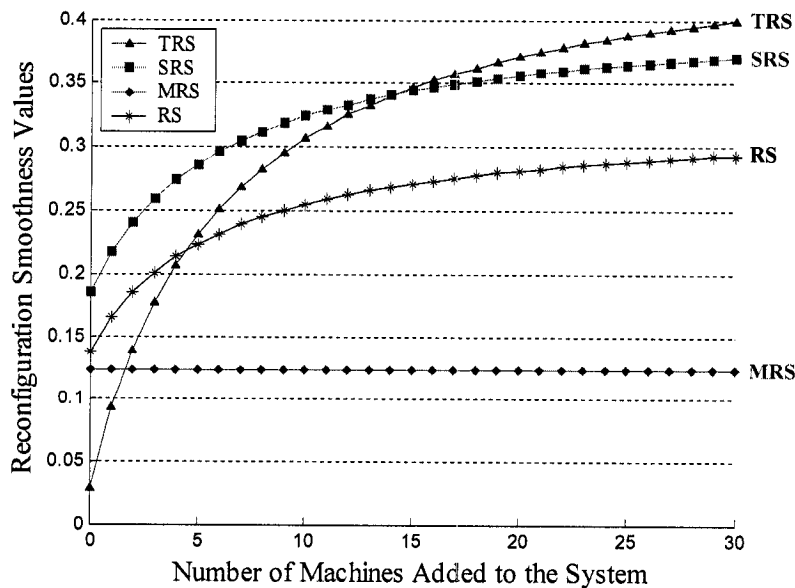

Figure (6.4) The effect of adding machines to the system on RS values.

Figure 6.5 shows that the MRS value is the most sensitive to the number of machine modules added to the system due to the fact that this number reflects the effort and time of machine-level reconfiguration. The SRS, on the other hand, is insensitive to this number as the system level is concerned with higher-level activities of reconfiguration.

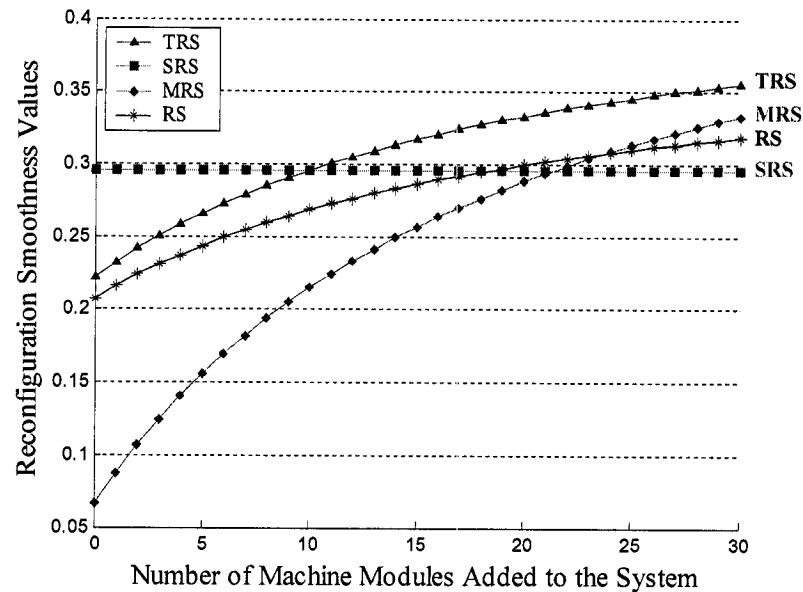

Figure (6.5) The effect of adding machine modules to the system on RS values.

The sensitivity of the various RS components (TRS, SRS, MRS or RS) to the addition of system modules (stages, machines or machine modules) decreases as the number of added modules increases as shown in Figures 6.3-6.5. This is due to the fact that the developed metric is based on evaluations that are relative to the total number of modules available in the system. This further illustrates the merits of the developed metric as it takes into consideration the scale of change involved in the reconfiguration process.

## 6.5 Summary and Conclusions

It is essential to consider the influence of manufacturing systems configuration selection on the smoothness of the subsequent reconfiguration process. This chapter introduced the term “*Reconfiguration Smoothness*” and presented a metric to evaluate it. This metric reflects the activities associated with different levels of reconfiguration; market-level, system-level and machine-level. The developed metric considers the

influence of individual reconfiguration activities at more than one reconfiguration level, each from its perspective. For example, the addition/removal of machines affects both the market-level (TRS) and the system-level (SRS) and the addition/removal of machine modules affects both the market-level (TRS) and the machine-level (MRS).

Rules were developed to guide the decisions concerning the execution of the reconfiguration process, which was called “*Reconfiguration Planning*”. A procedure, based on these rules, was introduced in order to automate the determination of exact stage locations for new configurations and accordingly automate the development of step-by-step actions plans that are practical and easy to implement in order to reconfigure the system from existing configurations to new ones. This prevents human interventions that are based on subjective decisions in executing the reconfiguration activities and helps in the automatic evaluation of the RS metric. A case study was presented to demonstrate the use of the reconfiguration planning rules and the developed RS metric. Sensitivity analysis was performed to show the effect of changing different metric parameters on its value and accordingly on the configuration selection decisions.

The proposed RS metric provides a quantitative assessment for characteristics of manufacturing systems that make certain feasible candidate configurations inherently better than others in terms of smoothness of reconfiguration from a current configuration as illustrated by the case study. These RS evaluations can be provided to the higher-level management to support their decision-making regarding the configuration selection

The presented method and metric consider only the next production planning period. The next chapter extends this reconfiguration smoothness (RS) analysis. It provides a model for optimizing the RS evaluation over all future configuration periods in the planning horizon of the system taking into consideration the stochastic nature of the anticipated configurations corresponding to future demand scenarios.

## 7. STOCHASTIC EVALUATION OF RECONFIGURATION SMOOTHNESS ACROSS THE PLANNING HORIZON

This chapter extends the reconfiguration smoothness (RS) analysis, presented in the previous chapter, to consider all future configuration periods within the planning horizon of the RMS. The chapter starts by demonstrating the concept of “*Reconfiguration Smoothness*” from a stochastic perspective that was introduced by Youssef and H. ElMaraghy (2006a). This is followed by describing a stochastic model that utilizes the RS evaluations to determine the degree of reconfiguration smoothness across (RSA) corresponding to any candidate set of configurations corresponding to all the demand scenarios (DSs) at different configuration periods (CPs). This model is based on the probability of occurrence of each DS within its CP in addition to predetermined relative importance of each CP in the RSA evaluation. The use of GAs and RTS to select near-optimal sets of configurations, corresponding to the different DSs at different CPs, that optimizes the RSA is presented and applied to a case study based on the outcome results of the first stage of the RMS Configuration Selection Approach. The second stage of the approach is, then, concluded and the results of the overall approach are reported followed by a discussion.

### 7.1 Stochastic Reconfiguration Smoothness

The evaluation of the reconfiguration smoothness has to be considered from a stochastic perspective to be able to handle the different future demand expectations. The probability theory is utilized, when there is more than one possibility (scenario) for the next configuration (see Section 3.1.2), in order to evaluate the expected value of reconfiguration smoothness (RS) between the two consecutive periods for the specific configurations selected for each demand scenario (DS). Figure 7.1 gives an example of evaluating the RS stochastically where  $C_{ij}$  represents the configuration selected for demand scenario  $DS_{ij}$ .  $C_{ij}$  will be in the form presented previously in Figure 3.1.

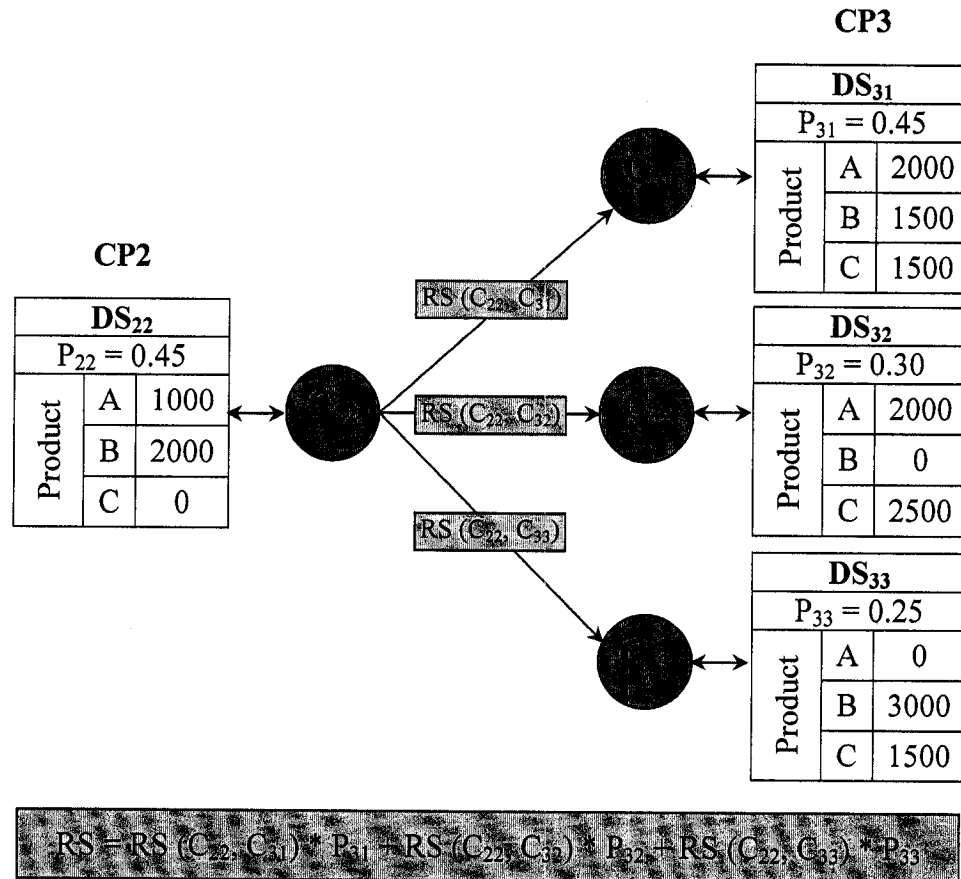

Figure (7.1) An example of stochastic evaluation of reconfiguration smoothness (RS) (Youssef and H. ElMaraghy 2006a).

## 7.2 Reconfiguration Smoothness Across (RSA)

The Reconfiguration Smoothness Across (RSA) extends the stochastic evaluation of the RS, described in the previous section, to incorporate the RS evaluations of all pairs of possible consecutive configurations within a set of configurations corresponding to all the anticipated demand scenarios (DSs) at different configuration periods (CPs). This is performed by taking into consideration the accumulated probability of occurrence of each possible pair of configurations and multiplying that by the RS evaluation of that pair.

In addition, the closeness of the configuration period (CP), for which a pairwise RS evaluation is performed, to the current period has to influence the effect of this RS evaluation on the overall RSA evaluation. This is attained by assigning a relative importance (RI) to each CP in the RSA evaluation. It is quite clear that the closer the



period is to the current period, the more important it should be to the overall RSA evaluation and the current CP (the CP of interest) should be given the highest RI value. The relative importance corresponding to a specific CP is multiplied by the RS evaluations of all possible pairs of configurations that belong to this CP. Accordingly, the RSA is obtained by summing up the pairwise RS evaluations of all possible consecutive pairs of configurations multiplied by their accumulated probabilities of occurrence multiplied by the RIs of the CPs to which these pairs belong.

The probabilities of occurrence for different DSs that belong to the same CP should sum up to 1 (see Section 3.1.2). Accordingly, the summation of the accumulated probabilities of occurrence of all possible consecutive pairs of configurations among a selected set of configurations will sum up to NCP (the number of configuration periods). In addition, any pairwise RS evaluation lies between 0 and 1 (see Section 6.1). Therefore, the RIs assigned to all CPs should sum up to 1 in order to have the RSA value lie between 0 and 1.

Figure 7.2 gives an example of evaluating the RSA for a given set of selected configurations where  $RI_i$  represents the relative importance assigned for  $CP_i$  in the RSA evaluation,  $C_0$  is the configuration that was utilized in period  $CP_0$  (the period prior to the period of interest,  $CP_1$ ),  $P_{ij}$  is the probability of occurrence of  $DS_{ij}$  within  $CP_i$ ,  $C_{ij}$  represents the configuration selected for demand scenario  $DS_{ij}$  and  $C_{ij}$  is in the form presented previously in Figure 3.1. This example can be extended to evaluate sets of configurations for systems with different numbers of anticipated CPs and DSs.

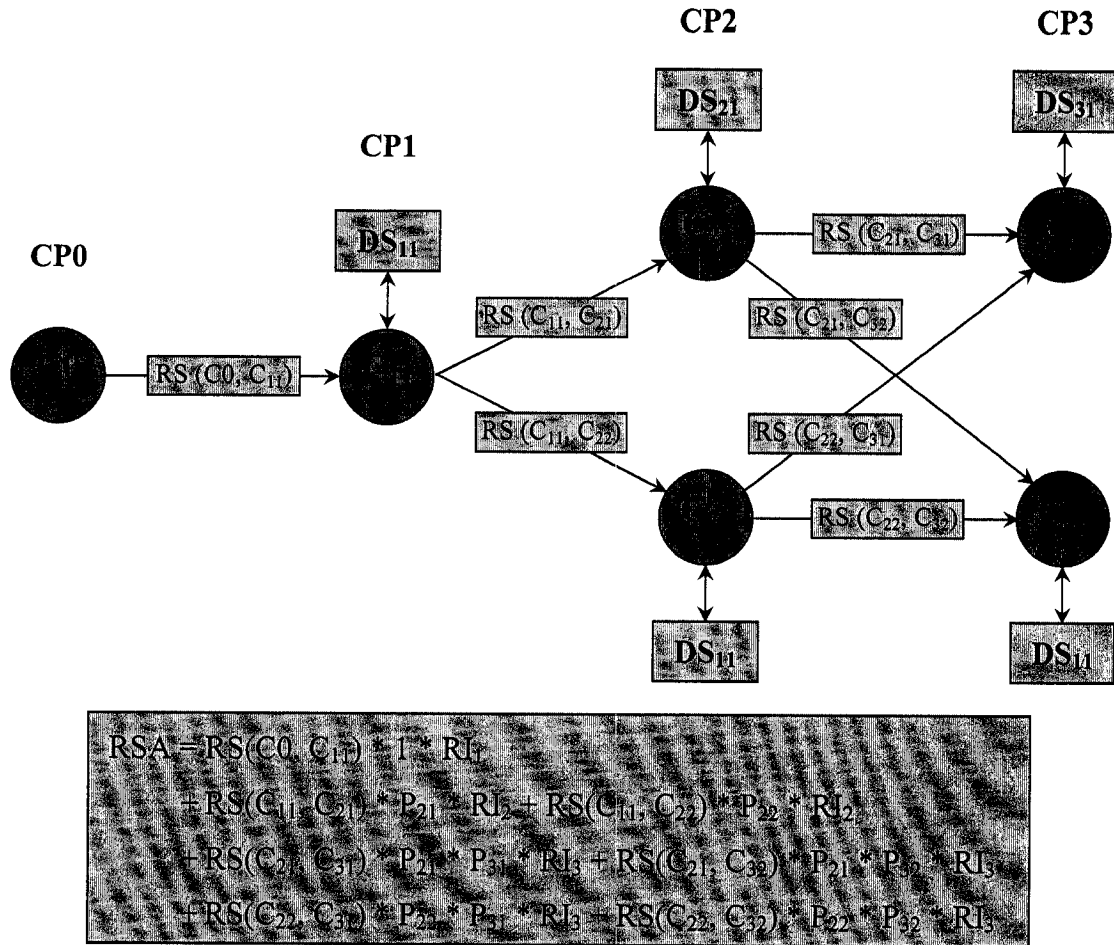

Figure (7.2) An example of RSA evaluation.

### 7.3 Optimization of Reconfiguration Smoothness Across (RSA)

The optimization procedure starts with determining an upper bound for the RSA which is called reconfiguration smoothness limit (RSL). The RSL is the RSA corresponding to the set of configurations composed of the best near-optimal configurations corresponding to the different DSs at different CPs (the best configuration for each DS among those generated from the first stage). This RSL is then used to constrain the optimization process, as it is not recommended to select a set of configurations with RSA inferior to that of the set of best configurations in addition to being inferior in terms of the criteria used in the first stage (cost and availability). A penalty function is used to ensure that the search tries to satisfy this constraint. If the

RSA value exceeds the maximum allowable value RSL, a penalty value of 100 multiplied by the exceeded value is added to the objective function value (the original RSA value).

In this optimization process, the different demand scenarios (DSs) are treated as variables for which the domains of values are the alternative configurations provided from the first step for each DS. This is a discrete optimization problem for which the search space has an order that is exponential in the total number of demand scenarios over all the considered configuration periods. Accordingly, the use of a powerful global (hill-climbing) optimization technique is a must. Integer-coded GAs (Appendix A) and a variant of TS, namely; Reactive Tabu Search (RTS) (Appendix C), were chosen, as meta-heuristics, to perform this optimization due to the same reasons that lead to the choice of GAs and TS with the continuous NP-hard problem of the first stage of the approach (see Chapter 4 for more details). The optimization is performed to generate and select a predefined number of near-optimal sets of configurations according to the RSA evaluation without violating the RSL.

## 7.4 Case Study

The stochastic model of optimizing the RSA was applied to a case study based on the two example parts, ANC-90 (part A) and ANC-101 (part B), and the available/obtainable resources previously described in Section 4.5.1 of Chapter 4. Both techniques, integer-coded GAs and RTS, were implemented for optimization after developing toolboxes for both of them and incorporating them into the main MATLAB toolbox, RMS-Configurator. Both optimization techniques are capable of generating a number of near-optimal sets of configurations in each run. This number is the minimum of two values; a predefined number (default is 10) or the number of sets of configurations within a specific predefined tolerance limit, regarding their evaluation, compared to the best of these sets (default is 5%).

Table 7.1 provides the population size, the number of generations and the number of times each operator is applied in the optimization of RSA using integer-coded GAs. On the other hand, the RTS stops when either the number of iterations reaches 100 or 50 iterations passes without improving in the best solution found so far.

Table (7.1) Parameters used in integer-coded GAs.

Parameter	Value
Population size	140
Number of generations	120
Number of times of cross-over application (arithmetic cross-over, simple cross-over and heuristic cross-over)	Four times for each operator
Number of times of mutation application (uniform mutation, boundary mutation, non-uniform mutation and whole non-uniform mutation)	Eight times for each operator

Now, consider the case of having an existing configuration C0 (Figure 7.3) that was utilized in the previous configuration period (CP0), the period prior to the period of interest (CP1), and having five CPs in the planning horizon of a RMS with different numbers of anticipated DSs. Table 7.2 provides all the information regarding the five CPs and their anticipated DSs including the duration of each CP, the relative importance (RI) of each CP regarding the RSA evaluation, the product mix and production volume requirements for each DS in each CP. The annual interest rate is assumed to be 12%. The system designer specified the maximum number of stages to be 10 and the maximum number of parallel machines per stage to be 8. The maximum allowable budget for initial investment is 60 million US Dollars.

S (SL)	1 (3)	2 (4)	3 (5)	4 (6)	5 (7)	6 (8)
M	1	1	1	2	2	1
MC	5	3	5	3	1	2
NMS	4	6	5	2	6	2
OS <sub>A</sub>	1	14	5	6	3	0
OS <sub>B</sub>	9	5	13	6	3	11

Figure (7.3) Configuration C0 of CP0.

Table (7.2) Case study information.

Configuration Periods Information			Demand Scenarios Information		
CP#	Duration (in years)	RI	DS#	Demand Requirements (in Parts/Hour)	
				Part A	Part B
CP1	1.5	0.45	DS <sub>11</sub>	120	180
CP2	1.0	0.25	DS <sub>21</sub>	220	0
			DS <sub>22</sub>	180	120
			DS <sub>31</sub>	120	180
CP3	1.2	0.15	DS <sub>32</sub>	180	180
			DS <sub>33</sub>	0	200
			DS <sub>41</sub>	0	220
CP4	1.5	0.10	DS <sub>42</sub>	120	120
			DS <sub>51</sub>	150	150
CP5	1.3	0.05	DS <sub>52</sub>	150	120
			DS <sub>53</sub>	120	150
			DS <sub>54</sub>	250	0

The first stage of the RMS Configuration Selection Approach had to run first in order to provide the second stage with the alternative configurations for each DS within each CP. The results of the first stage are presented in details in Appendix E.

#### 7.4.1 Optimization Results Using Integer-Coded GAs

The integer-coded GAs generated 10 near-optimal sets of configuration, each of which is composed of a number of selected configurations corresponding to the different possible demand scenarios (DSs) that were identified in Table 7.2 corresponding to all the configuration periods (CPs) within the planning horizon of the RMS. The first two sets have the same near-optimal value of 0.22335 for the RSA. All the remaining sets were within the specified tolerance of 5% from the near-optimal value and have the same value of 0.22336 for the RSA, which is very close to the best achieved value. Figure 7.4 demonstrates the GA convergence curve for this run. The computation time required by the developed MATLAB toolbox in this run to produce these solutions based on the presented optimization model was about 7.1 hours on a Pentium 4 3.4 GHz PC with 1.0 GB memory.

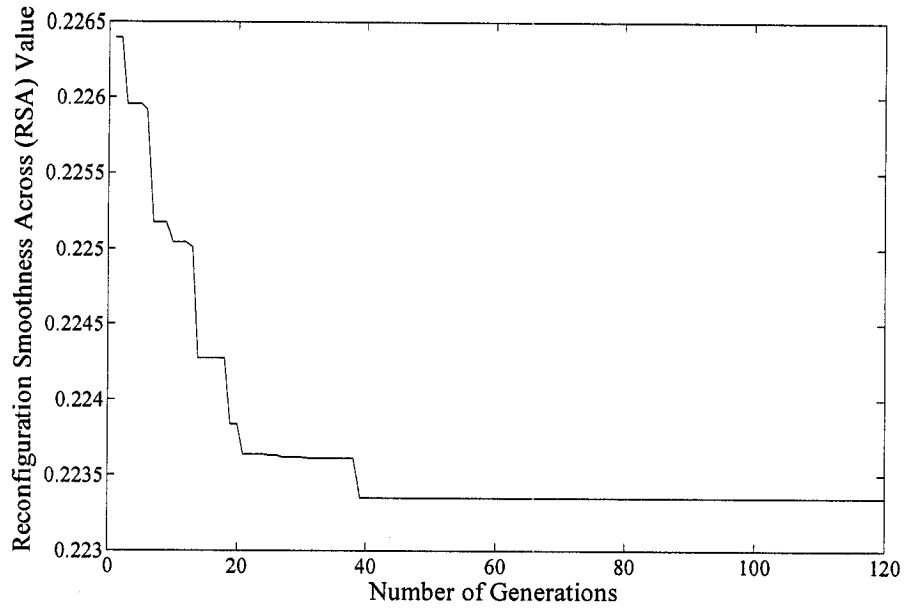

Figure (7.4) The GA convergence curve.

Figure 7.5 represents the first near-optimal set obtained in terms of the configurations selected from among those produced in the first stage (refer to Appendix E for the detailed description and characteristics of these configurations).

Configuration Period	Demand Scenario	Selected Configuration
CP1	DS <sub>11</sub>	Configuration #3
CP2	DS <sub>21</sub>	Configuration #8
	DS <sub>22</sub>	Configuration #6
CP3	DS <sub>31</sub>	Configuration #3
	DS <sub>32</sub>	Configuration #7
	DS <sub>33</sub>	Configuration #8
CP4	DS <sub>41</sub>	Configuration #4
	DS <sub>42</sub>	Configuration #2
CP5	DS <sub>51</sub>	Configuration #5
	DS <sub>52</sub>	Configuration #7
	DS <sub>53</sub>	Configuration #7
	DS <sub>54</sub>	Configuration #8

Figure (7.5) The first near-optimal set of selected configurations obtained by GAs.

Figure 7.6 represents the second near-optimal set of selected configurations obtained, which has the same value of 0.22335 for the RSA as the first set.

Configuration Period	Demand Scenario	Selected Configuration
CP1	DS <sub>11</sub>	Configuration #3
CP2	DS <sub>21</sub>	Configuration #8
	DS <sub>22</sub>	Configuration #6
CP3	DS <sub>31</sub>	Configuration #3
	DS <sub>32</sub>	Configuration #7
	DS <sub>33</sub>	Configuration #8
CP4	DS <sub>41</sub>	Configuration #4
	DS <sub>42</sub>	Configuration #2
CP5	DS <sub>51</sub>	Configuration #1
	DS <sub>52</sub>	Configuration #7
	DS <sub>53</sub>	Configuration #7
	DS <sub>54</sub>	Configuration #8

Figure (7.6) The second near-optimal set of selected configurations obtained by GAs.

It is noticed that both sets have the same selected configuration for the first configuration period (CP1) which is configuration #3 from those generated by the first stage for CP1. Therefore C1 (the configuration selected for CP1, the period of interest) is configuration #3 (Figure 7.7) from those generated by the first stage for CP1. The developed MATLAB toolbox, RMS-Configurator, provides, in addition to the near-optimal sets of configurations, the execution plans for reconfiguring the system from C0 to C1 of that set, which is configuration #3 for CP1 in this case, according to the reconfiguration planning rules.

S	1	2	3	4	5	6	7
(SL)	(1)	(2)	(3)	(4)	(5)	(6)	(7)
M	1	1	1	1	1	1	2
MC	2	3	2	5	2	5	2
NMS	3	3	3	7	2	4	6
OS <sub>A</sub>	1	0	14	5	0	3	6'
OS <sub>B</sub>	1	15	13	5	11	9	6

Figure (7.7) C1 (Configuration #3 from those generated for CP1).



C1 has the following characteristics:

- Capital cost of the configuration in present value = 7.7802 million US Dollars
- Initial investment in the configuration = 27.8200 million US Dollars
- Reconfiguration smoothness (RS) value of the configuration from C0 = 0.29392
- System availability of the configuration = 73.526%
- System expected production rate of the configuration for part A = 343 parts/hour
- System expected production rate of the configuration for part B = 284 parts/hour
- System utilization of the configuration = 98.3%
- Overall utility function evaluation of the configuration = 7,780.44292

The step-by-step action plan for reconfiguring the RMS from C0 to C1 is as follows:

I) Stages:

1. Stage of type M1 located in SL3 will keep its location in the system.
2. Stage of type M1 located in SL4 will keep its location in the system.
3. Stage of type M1 located in SL5 will keep its location in the system.
4. Stage of type M2 located in SL7 will keep its location in the system.
5. Stage of type M2 located in SL6 will be totally removed from the system.
6. Stage of type M1 located in SL8 will be relocated to SL1 of the system.
7. A new stage of type M1 will be added to SL2 of the system.
8. A new stage of type M1 will be added to SL6 of the system.

II) Machines:

1. 3 M1 machines located in SL3 will keep their location in the system.
2. 6 M1 machines located in SL4 will keep their location in the system.
3. 2 M1 machines located in SL5 will keep their location in the system.
4. 6 M2 machines located in SL7 will keep their location in the system.
5. 2 M2 machines located in SL6 will be totally removed from the system.
6. 1 M1 machine located in SL3 will be relocated to SL2 of the system.
7. 2 M1 machines located in SL5 will be relocated to SL2 of the system.
8. 1 M1 machine located in SL5 will be relocated to SL6 of the system.
9. 2 M1 machines located in SL8 will be relocated to SL1 of the system.
10. 1 new M1 machine will be added to SL1 of the system.

11. 1 new M1 machine will be added to SL4 of the system.
12. 3 new M1 machines will be added to SL6 of the system.

Details of the other near-optimal sets obtained by GAs and their corresponding selections of C1 and accordingly the reconfiguration actions plans from C0 to C1 can be found in Appendix E.

#### **7.4.2 Optimization Results Using RTS**

The Reactive Tabu Search (RTS) was applied to the same outcomes of the first stage that were used for the GAs optimization in order to be able to compare the results. RTS generated 10 near-optimal sets of configurations, each of which is composed of a number of selected configurations corresponding to the different possible demand scenarios (DSs) that were identified in Table 7.2 corresponding to all the configuration periods (CPs) within the planning horizon of the RMS. The first two sets have the same near-optimal value of 0.22335 for the RSA like GAs and are the same exact solutions (sets of configurations). All the remaining sets were within the specified tolerance of 5% from the near-optimal value and have the same value of 0.22336 for the RSA, which is very close to the best-achieved value. Figure 7.8 demonstrates the RTS convergence curve for this run. The computation time required by the developed MATLAB toolbox in this run to produce these solutions based on the presented optimization model was about 4.8 hours on a Pentium 4 3.4 GHz PC with 1.0 GB memory. The usual time/run for the RTS with these parameters would on average take more time but this run stopped before reaching 100 iterations because the other stopping criterion was satisfied (no improvement in the best solution found so far for 50 iterations) which lead to stopping after just 67 iterations .

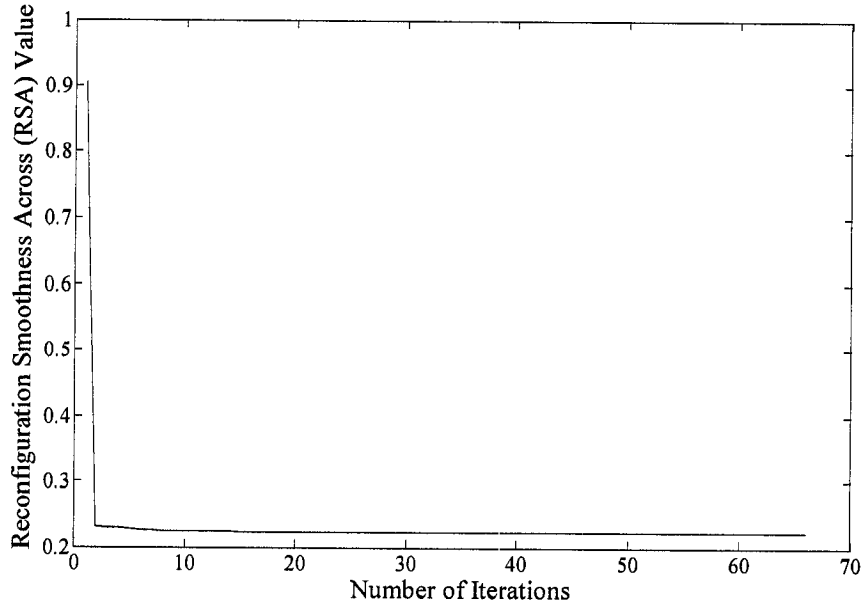

Figure (7.8) The RTS convergence curve.

Figure 7.9 represents the first near-optimal set obtained by RTS in terms of the configurations selected from among those produced in the first stage (refer to Appendix E for the detailed description and characteristics of these configurations). This set is identical to the first near-optimal set obtained by GAs (Figure 7.5) and obviously has the same RSA value of 0.22335.

Configuration Period	Demand Scenario	Selected Configuration
CP1	DS <sub>11</sub>	Configuration #3
CP2	DS <sub>21</sub>	Configuration #8
	DS <sub>22</sub>	Configuration #6
CP3	DS <sub>31</sub>	Configuration #3
	DS <sub>32</sub>	Configuration #7
	DS <sub>33</sub>	Configuration #8
CP4	DS <sub>41</sub>	Configuration #4
	DS <sub>42</sub>	Configuration #2
CP5	DS <sub>51</sub>	Configuration #5
	DS <sub>52</sub>	Configuration #7
	DS <sub>53</sub>	Configuration #7
	DS <sub>54</sub>	Configuration #8

Figure (7.9) The first near-optimal set of selected configurations obtained by RTS.

Figure 7.10 represents the second near-optimal set of selected configurations obtained by RTS, which was also identical to the second set obtained by GAs and has the same value of 0.22335 for the RSA.

Configuration Period	Demand Scenario	Selected Configuration
CP1	DS <sub>11</sub>	Configuration #3
CP2	DS <sub>21</sub>	Configuration #8
	DS <sub>22</sub>	Configuration #6
CP3	DS <sub>31</sub>	Configuration #3
	DS <sub>32</sub>	Configuration #7
	DS <sub>33</sub>	Configuration #8
CP4	DS <sub>41</sub>	Configuration #4
	DS <sub>42</sub>	Configuration #2
CP5	DS <sub>51</sub>	Configuration #1
	DS <sub>52</sub>	Configuration #7
	DS <sub>53</sub>	Configuration #7
	DS <sub>54</sub>	Configuration #8

Figure (7.10) The second near-optimal set of selected configurations obtained by RTS.

Both sets, which are identical to those obtained by GAs, have the same selected configuration for the first configuration period (CP1) which is configuration #3 from those generated by the first stage for CP1. Therefore C1 (the configuration selected for CP1, the period of interest) is configuration #3 (Figure 7.7) from those generated by the first stage for CP1. The developed MATLAB toolbox, RMS-Configurator, provides, in addition to the near-optimal sets of configurations, the execution plans for reconfiguring the system from C0 to C1 of that set, which is configuration #3 for CP1 in this case, according to the reconfiguration planning rules. The characteristics of C1 and the step-by-step action plan for reconfiguring the system from C0 to C1 have already been reported with the results of GAs in the previous section.

Details of the other near-optimal sets obtained by RTS and their corresponding selections of C1 and accordingly the reconfiguration actions plans from C0 to C1 can be found in Appendix E in which the original report using GAs for the second stage was appended by just the second stage portion of the report using RTS for the second stage with same first stage outcome results.

It is noticeable from comparing the outcomes of optimization and the performance of both optimization techniques, GAs and RTS, that the final results were consistent which validates the optimization model developed.

Generally, and from the outcomes of many other various runs, both techniques are usually consistent in reaching the same near-optimal values for RSA which indicates that they probably arrive at the global optimal value. Both techniques have, on average, the same time/run except if the second stopping criterion of RTS was triggered which gives better time/run for RTS. In most of the runs, RTS proved to be more powerful in terms of its capability to produce multiple near-optimal solutions with same objective function value, the best value arrived at, which is very useful for the decision maker to have different alternatives to choose from.

## 7.5 Summary and Conclusions

The stochastic nature of the future anticipations of demand requirements should be reflected in the analysis of reconfiguration smoothness along the planning horizon of a RMS. This chapter introduced the concept of stochastic evaluation of the reconfiguration smoothness by considering the different anticipations for future demand. A stochastic model that utilizes the RS evaluations, presented in Chapter 6, to determine the degree of reconfiguration smoothness across (RSA) corresponding to any candidate set of configurations corresponding to all the demand scenarios (DSs) at different configuration periods (CPs) was developed. This model is based on the estimated probability of occurrence of each DS within its CP in addition to predetermined relative importance of each CP in the RSA evaluation.

The use of GAs and RTS to select near-optimal sets of configurations that optimizes the RSA was presented. MATLAB toolboxes for both optimization techniques were developed and incorporated in the main toolbox, RMS-Configurator, which is the main tool for the overall RMS configuration Selection Approach. GAs and RTS were implemented using the toolbox, RMS-Configurator, to a case study based on the outcome results of the first stage of the RMS configuration Selection Approach. The results provide different alternative sets of configurations with the same RSA near-optimal

value. This gives flexibility for the system designer to choose among those alternative sets of configurations according to the performance of these configurations in the first stage (regarding cost and availability) or any other criteria that might be considered.

The results showed that the selected configuration for CP1 in the case study was the third ordered configuration from those produced in the first stage in terms of its cost and availability. Also the tentative selection of configurations for future periods confirms that same concept. This proves that the system configuration with best performance in a specific period may not be the best configuration for that period if the reconfiguration effort is considered over the planning horizon of the system.

This chapter concludes the second stage and accordingly the overall RMS Configuration Selection Approach. The output of this stage, and of the overall approach, is a number of candidate configurations for the current (first) CP (the period of interest). Each of these candidate configurations will be accompanied by a preliminary selection of a combination of configurations across all CPs that optimizes the RSA evaluation. The number of these selected sets of configurations (NSC) will be the minimum of two values; a predefined number (default is 10) or the number of configuration sets within a specific predefined tolerance limit, regarding their evaluation, compared to the best set (default is 5%). In addition, and for each of these sets, the execution plans for reconfiguring the system from C0 to C1 of that set is developed according to the reconfiguration planning rules.

The generated sets of configurations not only have near-optimal RSA evaluation but are guaranteed to be within a very small tolerance from the near-optimal configurations according to the predetermined system evaluation criteria used in the first stage (cost and availability).

## 8. CONCLUSIONS AND FUTURE WORK

Selection of system configuration is essential for RMSs in which the configuration life cycle is dynamic according to market changes and the capabilities of reconfiguration widen the possibilities of system level configurations. According to the literature review performed, there remain many challenges in the area of RMS configuration selection to be tackled.

The objective of the research presented was to develop an approach for selecting RMS configurations that provides optimal performance while maintaining the highest level of reconfiguration smoothness according to current and anticipated future demand requirements. To achieve this objective, several sub-problems had to be addressed, which include:

1. The formulation of a model for optimizing the capital cost and system availability of multiple-aspect RMS configurations.
2. The development of a constraint satisfaction procedure based on mapping from the discrete domain of decision variables to a continuous domain that guarantees the feasibility of the generated alternatives (multiple-aspect RMS configurations).
3. The development of a procedure, based on the Universal Generating Function (UGF) technique, for evaluating system availability of multi-state manufacturing systems (MSMS) capable of producing multiple part types simultaneously.
4. The development of a reconfiguration smoothness (RS) metric that provides relative assessment of the effort, time and cost of reconfiguration.
5. The development of a set of reconfiguration planning rules that helps determine the exact locations for the different production stages within the flow line configuration structure and guides the execution steps of the physical reconfiguration of the system whether these steps will lead to expansion or reduction in the system physical resources.
6. The development of a procedure for automatically determining the exact stage locations and generating the detailed step-by-step execution plans for reconfiguration.



7. The development of a stochastic model for evaluating the level of reconfiguration smoothness across all the configuration periods in the planning horizon.

## 8.1 Conclusions

The following concluding remarks can be pointed out of the presented research with regards to the problem under investigation (configuration selection for RMS):

1. The configuration structure of a flow line that allows paralleling of machines proved to be capable of achieving the desired configurations, for various demand scenarios at different configurations periods, that provide almost exactly the capacity needed when needed and thus achieving the capacity scalability requirements of RMS.
2. The use of meta-heuristic global optimization methods such as Genetic Algorithms (GAs) and Tabu Search (TS) is essential for the problem of optimizing multiple-aspect RMS configurations which proved to be NP-hard.
3. Different system configuration alternatives with same near-optimal capital cost can be attained. This provides an incentive for utilizing other system evaluation criteria in order to distinguish between these different alternatives.
4. The most economical configuration is not necessarily the most compressed one (i.e. the configuration where all stages are visited by all product types). It should be left to the outcomes of optimization to decide whether the stages would be used to serve single or multiple parts.
5. The Universal Generating Function (UGF) technique proved to be computationally efficient in terms of generating and continuously reducing the number of possible states of multi-state manufacturing systems (MSMS) based on similarity in the output performance. This helps in the assessment of expected production rate (throughput), system availability and utilization of large systems.
6. Considering availability with different scenarios (infinite buffer capacity or no buffer capacity) in the production rate (throughput) analysis of the manufacturing systems affects the decision of configuration selection, the number of equipments (machines and removable modules) being used and accordingly the cost of the near-optimal configurations. The difference between the near-optimal costs

arrived-at for both extremes (infinite and no buffer capacity cases) is large enough to motivate the investigation of the case in between (finite buffer capacity) to decide whether or not to incorporate buffer capacity between stages especially that this capacity will require additional expenses in terms of space and material handling equipment.

7. The number of production stages of the near-optimal configurations is mostly affected by the functionality requirements of the system while the number of machines in parallel for these configurations is mostly affected by the capacity requirements and availability considerations of the system. Thus, for a manufacturing system to be capable of providing the capacity and functionality needed when it is needed, it has to have flexibility in its length, expressed by the number of production stages, and its width, expressed by the number of machines in parallel.
8. The smoothness of subsequent reconfiguration processes is influenced by the initial manufacturing systems configuration selection as expected.
9. The selection decisions of the exact locations for different production stages within the flow line configuration structure and the reconfiguration execution plans from one configuration to the next have a tangible influence on the effort, time and cost of reconfiguration which is reflected in the reconfiguration smoothness values for different alternatives.
10. A reconfiguration execution plan has to include activities leading to both expansion and reduction in the system resources in order to achieve the capacity and functionality needed when needed.
11. The system configuration with best performance in a specific period may not be the best configuration for that period if the reconfiguration effort is considered over the planning horizon of the system.

The following additional concluding remarks can be highlighted with regards to the performance of the optimization techniques used to solve the problem of RMS configuration selection (GAs and TS):

12. The outcomes of optimization based on variants of TS were consistent compared to those based on GAs in most of the scenarios for both continuous and discrete optimization with regards to arriving at the same near-optimal configurations or sets of configurations and their corresponding objective function evaluations. This gives an indication that these solutions are probably the global optimal solutions. The only exception for that was in cases of constraint-congested solution spaces where feasibility is difficult to achieve. GAs showed superiority in arriving at better near-optimal configurations in these cases, namely, the problem of incorporating availability with no buffer capacity.
13. Variants of TS showed superiority to GAs in generating multiple near-optimal configurations with same objective function evaluation in the cases of relaxed solution spaces (less exhaustive problems). These include the optimization of RS across all configuration periods (discrete optimization) and the continuous domain problem of optimizing cost and availability in the scenarios of either not incorporating availability or considering availability with infinite buffer capacity.

The following general comments are worth noting and provide an insight for designers of manufacturing systems:

- It is essential to consider various aspects in the selection of system-level configurations for any manufacturing system including Reconfigurable Manufacturing Systems (RMS).
- System designers will always face tradeoff decisions between cost and availability, which provides a measure for the ability of a manufacturing system to meet targeted demand requirements.
- The stochastic nature of the future anticipations of demand requirements should be reflected in the analysis of reconfiguration smoothness along the planning horizon of a RMS.

The objective of RMS is to provide the capacity and functionality needed when needed with least amount of reconfiguration effort. It was shown that *“the use of stochastic analysis and rules-guided planning for the anticipated reconfiguration process*

*in the optimal selection of multiple-aspect RMS configurations, capable of producing multiple-part types simultaneously, achieves the RMS objective”.*

## **8.2 Research Contributions**

The reported research makes the following contributions to the fields of performance analysis, reconfiguration smoothness evaluation, reconfiguration planning and configurations selection for Reconfigurable Manufacturing Systems:

1. A new approach, RMS Configuration Selection Approach, for selecting RMS configurations is developed. It addresses most of the shortcomings of the previous work that dealt with the same problem as it considers more than one aspect of the system configuration (arrangement of machines, equipment selection and assignment of operations), utilizes important system-level evaluation criteria (capital cost and system availability) and involves stochastic analysis to take into consideration the smoothness of the anticipated reconfiguration process. In addition, it provides detailed reconfiguration planning steps that enable activities leading to both expansion and reduction in the system resources.
2. A novel procedure was developed and utilized to overcome the constraint satisfaction challenge of generating feasible alternative multiple-aspect RMS configurations. It is based on mapping of the decision variables from their original discrete domain into a continuous domain of variables. The new continuous domain of variables not only guarantees the satisfaction of the specified constraints but also provides variables that are not function of the number of stages of the candidate configurations. This produces solution strings that are easy to manipulate using different types of operators, such as crossovers or mutations, without violating the constraints or changing the size of the solution string. In addition, the developed procedure drastically reduces the number of control variables and the size of the search space. The developed procedure is general and can be applied to complex parts with large number of features and systems with large number of stages and large number of available resources in reasonable time. In addition, it is applicable to configuration selection of any manufacturing system with similar structure and not limited to RMS. Other manufacturing

systems that can have similar structure (flow line allowing paralleling of machines) include Dedicated FMS (Groover 2001), High Volume FMS “HV-FMS” (Fukaya 2004) and Homogeneous Paralleling Flow Lines “HPFL” (Son 2000a).

3. The use of the Universal Generating Function (UGF) technique in performance analysis of Multi-State Manufacturing Systems (MSMS) was introduced. It was utilized in the production rate (throughput) analysis and the assessment of system availability of MSMS considering machine availability. A modification was applied to the original technique to be capable of dealing with multiple types of output performance, which allows evaluating the availability of manufacturing systems that produce more than one part type simultaneously. The use of such a computationally powerful technique has an important significance in the field of manufacturing systems performance evaluation. It permits the evaluation of large systems in reasonable time which can be applied in the optimization of manufacturing systems configurations, the assessment of manufacturing systems complexity and evaluation of the expected productivity of large systems.
4. An analysis of the influence of incorporating machine availability in the optimization of RMS configurations was performed under different conditions (with infinite buffer capacity and with no buffer capacity) and the results were compared. This gives an insight about the effect of using buffers in the system structure and the influence of changing the functionality and capacity requirements of the system on both its configuration length and width.
5. A reconfiguration smoothness (RS) metric that gives a relative indication of the effort, cost and time of reconfiguring the system from one configuration to the next was developed. The RS metric considers the influence of individual reconfiguration activities at more than one reconfiguration level, each from its perspective. It provides a quantitative assessment for characteristics of manufacturing systems that make certain feasible candidate configurations inherently better than others in terms of smoothness of reconfiguration from a current configuration.

6. Rules, called “*Reconfiguration Planning Rules*”, were introduced to help determine the exact locations for the different production stages within the flow line configuration structure and guide the development of execution plans for system-level reconfiguration which include activities leading to both expansion and reduction in the system resources. A procedure was developed for automatically determining the exact stage locations and generating these reconfigurations plans. The developed plans provide step-by-step detailed procedures for reconfiguring the system and accordingly prevent any human interventions in the decision making at this stage that would be mostly subjective. The appropriate selection of the production stage locations as well as the reconfiguration execution plans help in reducing the physical reconfiguration effort. In addition, the detailed step-by-step reconfiguration execution plans developed by the procedure provide a practically natural sequence of reconfiguration steps from an implementation point of view.
7. A stochastic model for evaluating the reconfiguration smoothness across all configuration periods along the planning horizon of the system was introduced. It considers all possible demand scenarios that have probability of occurrence in the future. This model gives a clear indication of the effect of the selection of the system configuration for the current period on the anticipated reconfiguration effort along the planning horizon of the system. This is important to consider when dealing with RMSs that are expected to be dynamically reconfiguring along their lifetime to be able to provide the capacity and functionality needed when needed.
8. The use of different variants of powerful optimization techniques, GAs and TS, provides a reliable means of validation for the outcome results of optimization in both stages of the approach. These techniques are not only capable of reaching solutions of high quality in terms of the specified system evaluation criteria but are also capable of providing multiple different alternative solutions in order of their performance. This enables the system designer to have flexibility regarding the configuration selection decisions based on other criteria to be considered.



9. A tool, RMS-Configurator, implementing the developed approach was developed using MATLAB software. This tool provides a practical means of performance evaluation of manufacturing systems in addition to selection of RMS configurations.

### 8.3 Future Work

A number of future research topics can be drawn from the presented research. These include:

1. Considering additional aspects of the RMS configuration structure such as layout, material handling systems, etc. to be used with different types of equipment and investigating how this will affect the configuration selection decisions.
2. Expanding the cost model to incorporate cost elements other than the capital cost of equipment such as operating and setup costs, which might have an influence on the configuration selection decisions.
3. Incorporating system evaluation criteria, other than cost and availability, in the assessment of the candidate RMS configurations needs further investigation. Candidate additional criteria include quality, production rate (throughput), productivity, routing flexibility, system complexity, system responsiveness and others.
4. Using the modified UGF technique in performance analysis while incorporating the availability down to the machines components (modules) level, rather than just the individual machines level, based on the type of inter-dependency of the different machines modules and their effect on the performance of each individual machine as a whole.
5. Extending the use of the modified UGF technique in performance evaluation of manufacturing systems to be applied to system complexity (H. ElMaraghy *et al.*, 2005) and expected productivity (Koren *et al.*, 1998) of large systems.
6. Investigating the effect of using finite buffer capacity between different production stages and developing models for that based on the UGF technique or other models from the literature, if any exists. This can be compared to the results of the above-mentioned scenarios in quest for the justification of using or not



using buffer capacity for the proposed RMS configuration structure. This has to take in consideration the costs incurred by adding buffer capacity in terms of space and material handling equipment.

7. Developing accurate reconfiguration cost models pending the availability of sufficient information based on the state of the art of the technological enablers of RMS. This can be applied to case studies and the results to be compared to the outcomes of the developed RS metric.
8. Investigating the use of a hybrid optimization scheme in solving the continuous optimization problem especially in the case of no buffer capacity. This scheme can combine both GAs and M-C-RTS and have the merits of both techniques. One way to do that is to have M-C-RTS start with the end results of GAs.
9. Investigating the dynamic determination of the termination criteria of the optimization methods being used, GAs and TS, as a function of the problem size.

## 8.4 Summary

In summary, the presented research provides enhancements and contributions to the existing knowledge about manufacturing systems with regards to performance evaluation and configuration selection on both practical and theoretical levels. This will help in supporting the management decisions regarding system configurations for a RMS by providing the best alternatives at the beginning of each configuration period. This will lead to Reconfigurable Manufacturing Systems (RMSs) that provide the functionality and capacity needed, when it is needed and achieve the best possible performance levels for each individual configuration while maintaining the highest level of reconfiguration smoothness over the lifetime of the system.

## REFERENCES

- Abdi, M.R. and Labib, A.W., 2003a, "A Design Strategy for Reconfigurable Manufacturing Systems (RMSs) Using Analytical Hierarchical Process (AHP): A Case Study", *International Journal of Production Research*, Vol. 41, n10, pp. 2273-2299.
- Abdi, M.R. and Labib, A.W., 2003b, "A RMS Design Interface for Products Analysis", *Proceedings of the CIRP 2nd International Conference on Reconfigurable Manufacturing*, Ann Arbor, Michigan, August.
- Abdi, M.R. and Labib, A.W., 2004, "Grouping and Selecting Products: The design key of Reconfigurable Manufacturing Systems (RMSs)", *International Journal of Production Research*, Vol. 43, n3, pp. 521-546.
- Aven, T., 1985, "Reliability/Availability Evaluations of Coherent Systems Based on Minimal Cut Sets", *Reliability Engineering*, Vol. 13, n2, pp. 93-104.
- Battiti, R. and Tecchiolli, G., 1994, "The Reactive Tabu Search", *ORSA Journal on Computing*, Vol. 6, pp. 126-140.
- Battiti, R. and Tecchiolli, G., 1996, "The Continuous Reactive Tabu Search: Blending Combinatorial Optimization and Stochastic Search for Global Optimization", *Annals of Operations Research*, Vol. 63, pp. 153-188.
- Bollinger, J.G. *et al.*, 1998, "Visionary Manufacturing Challenges for 2020", National Research Council Report, National Academy Press, Washington D.C.
- Chelouah, R. and Siarry, P., 2000, "Tabu Search Applied to Global Optimization", *European Journal of Operational Research*, Vol. 123, n2, pp. 256-270.
- Cochran, D.S., Arinez, J.F., Duda, J.W. and Linck, J., 2001, "A Decomposition Approach for Manufacturing System Design", *Journal of Manufacturing Systems*, Vol. 20, n6, pp. 371-389.
- ElMaraghy, H.A., 2002, "Flexible Manufacturing Systems", Lecture Notes, Course 0691431, University of Windsor.
- ElMaraghy, H.A., Kuzgunkaya, O. and Urbanic, R.J., 2005, "Manufacturing Systems Configuration Complexity", *Annals of the CIRP*, Vol. 54, n1, pp. 445-450.
- ElMaraghy, H.A., 2006, "Flexible and Reconfigurable Manufacturing Systems Paradigms", *International Journal of Flexible Manufacturing Systems*, Special Issue on Reconfigurable Manufacturing Systems. (In press)

Franze, F. and Speciale, N., 2001, "A Tabu-Search-Based Algorithm for Continuous Multim minima Problems", International Journal for Numerical Methods in Engineering, Vol. 50, pp. 665-680.

Fraser, N.M., Bernhardt, I., Jewkes, E.M. and Tajima, M., 2006, Engineering Economics in Canada, Third Edition, Pearson Education Canada Inc., Toronto, ON.

Fukaya, T., 2004, HIPARMS (Highly Productive and Reconfigurable Manufacturing System) Final Report, <http://www.ims.org/images/projects/hiparms/finalreport.pdf>.

Gen, M. and Cheng, R., 2000, Genetic Algorithms and Engineering Optimization, John Wiley and Sons, New York.

Glover, F., 1986, "Future Paths for Integer Programming and Links to Artificial Intelligence", Computers and Operations Research, Vol. 13, pp.533-549.

Glover, F., 1999, Tabu Search, Kluwer Academic Publishers.

Groover, M.P., 2001, Automation, Production Systems, and Computer-Integrated Manufacturing, Second Edition, Prentice-Hall Inc., New Jersey.

Gupta, S.K., Nau, D.S., Regli, W.C. and Zhang, G., 1994, "A Methodology for Systematic Generation and Evaluation of Alternative Operation Plans", Advances in Feature Based Manufacturing / Edited by Shah, J.J., Mantyla, M. and Nau, D.S., Elsevier.

Henderson, M.R., Srinath, G., Stage, R., Walker, K. and Regli, W., 1994, "Boundary Representation-Based Feature Identification", Advances in Feature Based Manufacturing / Edited by Shah, J.J., Mantyla, M. and Nau, D.S., Elsevier.

Herrera, F., Lozano, M. and Verdegay, J.L., 1998, "Tackling Real-Coded Genetic Algorithms: Operators and Tools for Behavioral Analysis", Artificial Intelligence Review, Vol. 12, n4, pp. 265-319.

Holland, J., 1975, Adaptation in Natural and Artificial Systems, University of Michigan Press, Ann Arbor, MI.

Hon, K.K.B., 2005, "Performance and Evaluation of Manufacturing Systems", Annals of the CIRP, Vol. 54, n2, pp. 675-690.

Hu, N., 1992, "Tabu Search Method with Random Moves for Globally Optimal Design", International Journal for Numerical Methods in Engineering, Vol. 35, pp.1055-1070.

Hummel, K.E. and Brown, C.W., 1989, "The Role of Features in the Implementation of Concurrent Product and Process Design", Proceedings of ASME Winter Annual Meeting, DE-Vol. 21, PED-Vol. 36, ASME, New York, pp. 1-8.

- Kimms, A., 2000, "Minimal Investment Budgets for Flow Line Configuration", IIE Transactions, Vol. 32, pp. 287-298.
- Kiritsis, D. and Porchet, M., 1996, "A Generic Petri Net Model for Dynamic Process Planning and Sequence Optimization", Advances in Engineering Software, Vol. 25, pp. 61-71.
- Kirkpatrick, S., Gellat, C.D. and Vecchi, M.P., 1983, "Optimization by Simulated Annealing", Science, Vol. 220, pp. 671-680.
- Koren, Y., Hu, S. J. and Weber, T. W., 1998, "Impact of Manufacturing System Configuration on Performance", Annals of the CIRP, Vol. 47, n1, pp. 369-372.
- Koren, Y., Heisel, U., Jovane, F., Moriwaki, T., Pritschow, G., Ulsoy, G. and Van Brussel, H., 1999, "Reconfigurable Manufacturing Systems", Annals of the CIRP, Vol. 48, n2, pp. 527-540.
- Kuo, C. H., 2001, "Resource Allocation and Performance Evaluation of the Reconfigurable Manufacturing Systems", Proceedings of the IEEE International Conference on Systems, Man and Cybernetics, Vol. 4, pp. 2451-2456.
- Kusiak, A. and Lee, G.H., 1995, "Design of Components and Manufacturing Systems for Reconfigurability", Proceedings of the 1st World Conference on Integrated Design and Process Technology, Dec. 6-9, the University of Texas at Austin, TX, pp. 14-20.
- Landers, R.G., Min, B.-K. and Koren, Y., 2001, "Reconfigurable Machine Tools", Annals of the CIRP, Vol. 50, n1, pp. 269-274.
- Lee, G.H., 1997, "Reconfigurability Consideration Design of Components and Manufacturing Systems", The International Journal of Advanced Manufacturing Technology, Vol. 13, n5, pp. 376-386.
- Lee, G.H., 1998, "Designs of Components and Manufacturing Systems for Agile Manufacturing", International Journal of Production Research, Vol. 36, n4, April, pp. 1023-1044.
- Levitin, G. and Lisnianski, A., 1999a, "Joint redundancy and Maintenance Optimization for Multistate Series-Parallel Systems", Reliability Engineering & System Safety, Vol. 64, n1, April, pp. 33-42.
- Levitin, G. and Lisnianski, A., 1999b, "Importance and Sensitivity Analysis of Multi-State Systems Using the Universal Generating Function Method", Reliability Engineering and System Safety, Vol. 65, n3, pp. 271-282.

- Levitin, G. and Lisnianski, A., 2000, "Optimization of Imperfect Preventive Maintenance for Multi-State Systems", *Reliability Engineering and System Safety*, Vol. 67, n2, pp. 193-203.
- Lewis, E.E., 1987, *Introduction to Reliability Engineering*, John Wiley and Sons, New York.
- Li, W.D., Ong, S.K. and Nee, A.Y.C., 2002, "Hybrid Genetic Algorithm and Simulated Annealing Approach for the Optimization of Process plans for Prismatic Parts", *International Journal of Production Research*, Vol. 40, n8, pp. 1899-1922.
- Limnios, N. and Oprisan, G., 2001, *Semi-Markov Processes and Reliability*, Birkhauser, Boston.
- Lisnianski, A. and Levitin, G., 2003, *Multi-State System Reliability*, World Scientific, Singapore.
- Maier-Sperdelozzi, V. and Hu, S.J., 2002, "Selecting Manufacturing System Configurations Based on Performance Using AHP", *Technical Paper - Society of Manufacturing Engineers*. MS, n MS02-179, pp. 1-8.
- Maier-Sperdelozzi, V., Koren, Y. and Hu, S.J., 2003, "Convertibility Measures for Manufacturing Systems", *Annals of the CIRP*, Vol. 52, n1, pp. 367-370.
- Makino, H. and Trai, T., 1994, "New Developments in Assembly Systems", *Annals of the CIRP*, Vol. 43, n2, pp. 501-522.
- Matta, A., Tolio, T., Karaesmen, F. and Dallery, Y., 2001, "An Integrated Approach for the Configuration of Automated Manufacturing Systems", *Robotics and Computer Integrated Manufacturing*, Vol. 17, pp. 19-26.
- Mehrabi, M.G., Ulsoy, A.G. and Koren, Y., 2000, "Reconfigurable Manufacturing Systems: Key to Future Manufacturing", *Journal of Intelligent Manufacturing*, Vol. 11, pp. 403-419.
- Michalewicz, Z., Logan, T.D. and Swaminathan, S., 1994, "Evolutionary Operators for Continuous Convex Parameter Spaces", *Proceedings of the 4th International Conference on Evolutionary Computation*, pp. 84-107.
- Nahmias, S., 2001, *Production and Operations Analysis*, Fourth Edition, McGraw-Hill, New York.
- Ohiro, T., Myreshka, Morikawa, K. and Takahashi, K., 2003, "A Stochastic Model for Deciding an Optimal Production Order and its Corresponding Configuration in a Reconfigurable Manufacturing System with Multiple Product Groups", *Proceedings of*

the CIRP 2nd International Conference on Reconfigurable Manufacturing, Michigan, August.

Ong, S.K., Ding, J. and Nee, A.Y.C., 2002, "Hybrid GA and SA Dynamic Set-Up Planning Optimization", International Journal of Production Research, Vol. 40, n18, pp. 4697-4719.

Parzen, E., 1960, Modern Probability Theory and its Applications, John Wiley and Sons, New York.

Patel, J.K., Kapadia, C.H. and Owen, D.B., 1976, Handbook of Statistical Distribution, Marcel Dekker, New York.

Pham, D.T., and Karaboga, D., 2000, Intelligent Optimization Techniques, Genetic Algorithms, Tabu Search, Simulated Annealing and Neural Networks, Springer-Verlag, Berlin.

Rao, S.S., 1999, Engineering Optimization, Theory and Practice, John-Wiley and Sons, New York.

Siarry, P. and Berthiau, G., 1997, "Fitting of Tabu Search to Optimize Functions of Continuous Variables", International Journal for Numerical Methods in Engineering, Vol. 40, pp. 2449-2457.

Son, S. Y., 2000a, "Design Principles and Methodologies for Reconfigurable Machining Systems", Ph.D. Dissertation, University of Michigan.

Son, S.Y., Olsen, T.L. and Yip-Hoi, D., 2000b, "A Genetic Algorithm Approach for the Design of Machining System Families", Proceedings of the International CIRP Design Seminar, Design with Manufacturing: Intelligent Design Concepts, Methods and Algorithms, Haifa, Israel.

Spicer, P., Koren, Y., Shpitalni, M. and Yip-Hoi, D., 2002a, "Design Principles for Machining System Configurations", Annals of the CIRP, Vol. 51, n1, pp. 275-280.

Spicer, J.P., 2002b, "A Design Methodology for Scalable Machining Systems", Ph.D. Dissertation, University of Michigan.

Tang, L., Yip-Hoi, D. M., Wang, W. and Koren, Y., 2004, "Concurrent Line-Balancing, Equipment Selection and Throughput Analysis for Multi-Part Optimal Line Design", International Journal for Manufacturing Science and Production, Vol. 6, Nos. 1-2, pp. 71-81.

Tang, L., Yip-Hoi, D.M., Wang, W. and Koren, Y., 2005, "Selection Principles on Manufacturing System for Part Family", Proceedings of the CIRP 3rd International Conference on Reconfigurable Manufacturing, Ann Arbor, Michigan, May 10-12.



Tesfamariam Semere, D., 2005, "Configuration Design of a High Performance and Responsive Manufacturing System", Ph.D. Dissertation, KTH Royal Institute of Technology, Stockholm, Sweden.

Toenshoff, H.K., Schnuelle, A., Rietz, W., 2001, "Planning of Manufacturing Systems with Methods Analogous to Nature", International CIRP Design Seminar, Stockholm, pp. 255-260.

Ushakov, I.A., 1986, "A Universal Generating Function", Soviet Journal of Computing System Science, Vol. 24, n5, pp. 118-129.

Ushakov, I.A. and Harrison, R.A., 1993, Handbook of Reliability Engineering, John Wiley and Sons, New York.

Vesely, W.E., Goldberg, F.F., Roberts, N.H. and Haasl, D.F., 1981, "Fault Tree Handbook", NUREG-0492, U.S. Nuclear Regulatory Commission, Washington D.C..

Wiendahl, H.-P. and Heger, C. L., 2003, "Justifying Changeability: A Methodical Approach to Achieving Cost Effectiveness", Proceedings of the CIRP 2nd International Conference on Reconfigurable Manufacturing, Michigan, August.

Xiaobo, Z., Jiancai, W. and Zhenbi, L., 2000a, "A Stochastic Model of a Reconfigurable Manufacturing System. Part 1: A Framework", International Journal of Production Research, Vol. 38, n10, pp. 2273-2285.

Xiaobo, Z., Wang, J. and Luo, Z., 2000b, "A Stochastic Model of a Reconfigurable Manufacturing System. Part 2: Optimal Configurations", International Journal of Production Research, Vol. 38, n12, pp. 2829-2842.

Xiaobo, Z., Wang, J. and Luo, Z., 2001a, "A Stochastic Model of a Reconfigurable Manufacturing System. Part 3: Optimal Selection Policy", International Journal of Production Research, Vol. 39, n4, pp. 747-758.

Xiaobo, Z., Wang, J. and Luo, Z., 2001b, "A Stochastic Model of a Reconfigurable Manufacturing System. Part 4: Performance Measure", International Journal of Production Research, Vol. 39, n6, pp. 1113-1126.

Yamada, Y., Ookoudo, K. and Komura, Y., 2003, "Layout Optimization of Manufacturing Cells and Allocation Optimization of Transport Robots in Reconfigurable Manufacturing Systems Using Particle Swarm Optimization", IEEE International Conference on Intelligent Robots and Systems, Vol. 2, pp. 2049-2054.

Yang, S. and Hu, S.J., 2000a, "Productivity Analysis of a Six CNC Machine Manufacturing System with Different Configurations", Proceedings of the 2000 Japan-USA Flexible Automation Conference, Michigan, July, pp. 499-505.



Yang, S., Wu, C. and Hu, S. J., 2000b, "Modeling and Analysis of Multi-Stage Transfer Lines with Unreliable Machines and Finite Buffers", *Annals of Operations Research*, Vol. 93, pp. 405-421.

Youssef, A.M.A., 2001, "Reverse Engineering of Geometric Surfaces Using Tabu Search Optimization Technique", M.Sc. Thesis, Cairo University, Cairo, Egypt.

Youssef, A.M.A. and ElMaraghy, H.A., 2004, "System Configuration Selection for RMS", *Proceedings of the International Workshop on Advanced Manufacturing Technologies and Integrated Systems AMT 2004*, NRC-IMTI, London, Ontario, June 1-2.

Youssef, A.M.A. and ElMaraghy, H.A., 2005, "A New Approach for RMS Configuration Selection", *Proceedings of the CIRP 3rd International Conference on Reconfigurable Manufacturing*, Ann Arbor, Michigan, May 10-12.

Youssef, A.M.A. and ElMaraghy, H.A., 2006a, "Assessment of Manufacturing Systems Reconfiguration Smoothness", *International Journal of Advanced Manufacturing Technology*, paper DOI 10.1007/s00170-005-0034-9. (Online)

Youssef, A.M.A., Mohib, A. and ElMaraghy, H.A., 2006b, "Availability Assessment of Multi-State Manufacturing Systems Using Universal Generating Function", *Annals of the CIRP*, Vol. 55, n1, pp.445-448.

Youssef, A.M.A. and ElMaraghy, H.A., 2006c, "Modelling and Optimization of Multiple-Aspect RMS Configurations", *International Journal of Production Research*, Special Issue on Advances in Evolutionary Computation for Design and Manufacturing Problems, paper reference # IJPR-EC-33. (In press)

Youssef, A.M.A. and ElMaraghy, H.A., 2006d, "Availability Consideration in the Optimal Selection of Multiple-Aspect RMS Configurations", *International Journal of Production Research*. (Submitted)

Youssef, H., Sait, S.M. and Adiche, H., 2001, "Evolutionary Algorithms, Simulated Annealing and Tabu Search, a Comparative Study", *Engineering Applications of Artificial Intelligence*, Vol. 14, pp. 167-181.

Zhong, W., Maier-Sperdelozzi, V., Bratzel, A., Yang, S., Chick, S. E. and Hu, S.J., 2000, "Performance Analysis of Machining Systems with Different Configurations", *Proceedings of the 2000 Japan-USA Flexible Automation Conference*, Michigan, July, pp. 783-790.

## APPENDIX A: GENETIC ALGORITHMS

This appendix is provided to give a brief idea about Genetic Algorithms (GAs) and the operators used for real-coded GAs.

### A.1 General Overview of Genetic Algorithms

The following pseudo-code gives the general overview of a Genetic Algorithm:

1. Let  $F(x_1, \dots, x_m)$  be an objective function to be optimized, where  $(x_1, \dots, x_m)$  are the independent variables, where each variable  $x_i$  ranges between a lower and an upper limit  $[v_{min}, v_{max}]_i$ .
2. Convert the function  $F$  from a minimization to a maximization problem, where a new function  $f(F)$  is to be maximized. The new function is known as the fitness function.
3. Generate a random population  $P$  of  $N$  instances of the independent variables (known as **chromosomes**).
4. For a pre-specified number of generations (iterations)
  - a. Let the total number of offspring chromosomes due to the application of the mutation and cross over operators be denoted by  $M$ .
  - b. Use the **selection** operator to fill a new population with  $N-M$  high fitness chromosomes.
  - c. Use the **selection** operator along with the **mutation** and **cross over** operators to fill the remaining  $M$  locations in the population.
  - d. For the new population, evaluate the objective function (and fitness) value for the chromosomes changed by cross over and mutation, and retain the fitness values of the unchanged chromosomes.
5. End

## A.2 Operators Used for Real-Coded Genetic Algorithms

This section provides a brief description of the operators used in the real-coded Genetic Algorithms. The same types of operators apply for integer-coded GAs with the small difference of dealing with discrete domains of decision variables rather than continuous domains. This can be achieved by splitting the  $[0,1]$  ranges of the continuous domains into a number of equal divisions representing the different values in the discrete domains for each variable. Same kinds of operators can be applied accordingly.

### A.2.1 Selection Operators

The selection scheme adopted is an elitist tournament selection, where the best chromosome is retained between successive generations, to ensure that there is no loss of the best-obtained chromosome. The tournament selection is modified to accommodate the selection of low fitness chromosomes as well as high fitness chromosomes. This modification is necessary as some mutation operators operate on low fitness chromosomes.

### A.2.2 Cross-Over Operators

Cross-over operators change chromosomes in a semi-local fashion to produce new chromosomes in the vicinity of the old ones, and hence should be used on chromosomes with high fitness values. Three cross-over operators were used in his work:

#### A.2.2.1 Arithmetic Cross-Over

Given a pair of chromosomes:

$$\underline{X}_1 = \{x_1^1, x_2^1, x_3^1, \dots, x_n^1\}$$

$$\underline{X}_2 = \{x_1^2, x_2^2, x_3^2, \dots, x_n^2\}$$

Generate a random number  $\alpha$  between  $[0,1]$  and produce the new chromosomes  $\underline{Y}_1$  and  $\underline{Y}_2$ , where:

$$\underline{Y}_1 = \alpha \bar{x}_1 + (1 - \alpha)\bar{x}_2$$

$$\underline{Y}_2 = (1 - \alpha)\bar{x}_1 + \alpha \bar{x}_2$$

This operator produces new chromosomes on a straight line joining the parent chromosomes. It has some kind of an averaging effect between the values of the parent chromosomes. Such operator is useful when a minima is located between the parent chromosomes.

#### A.2.2.2 Simple Cross-Over

Simple cross-over simulates the bit swapping found in the cross-over operator of binary coded Genetic Algorithms. Given a pair of parent chromosomes:

$$\underline{X}_1 = \{x_1^1, x_2^1, x_3^1, \dots, x_k^1, \dots, x_n^1\}$$

$$\underline{X}_2 = \{x_1^2, x_2^2, x_3^2, \dots, x_k^2, \dots, x_n^2\}$$

Choose a random location  $k$ , and produce the new chromosomes  $\underline{Y}_1$  and  $\underline{Y}_2$ , by swapping the values in both chromosomes to the right of the location  $k$ .

$$\underline{Y}_1 = \{x_1^1, \dots, x_k^1, x_{k+1}^2, \dots, x_n^2\}$$

$$\underline{Y}_2 = \{x_1^2, \dots, x_k^2, x_{k+1}^1, \dots, x_n^1\}$$

This operator acts as an averaging search mechanism along the dimensions of the parent chromosomes.

#### A.2.2.3 Heuristic Cross-Over

Heuristic cross-over was introduced by Michalewicz *et al.* (1994) to add a steepest-descent search element to the genetic search, to fine-tune the solutions. Given a pair of chromosomes  $\underline{X}_1$  and  $\underline{X}_2$ , find  $f(\underline{X}_1)$  and  $f(\underline{X}_2)$ , where  $f$  is the objective function value in case of minimization. Generate  $\bar{x}_3$  along the direction of the lower objective function value, where:

$$\underline{X}_3 = r \cdot (\underline{X}_2 - \underline{X}_1) + \underline{X}_2$$

$r$  = random number between [0,1]

If the boundaries are exceeded then repair the value of  $\bar{x}_3$  to stop at the boundary.

#### A.2.3 Mutation Operators

Mutation operators are random search elements within the genetic search that diversify the search within the domain of the independent variables. Since there is no

guarantee that the generated chromosomes will have a better objective function values, therefore the parent chromosome on which the operator is applied should be chosen from among the low fitness chromosomes. Four mutation operators were used in his work:

#### A.2.3.1 Uniform Mutation

Given a chromosome  $\underline{X} = \{x_1, \dots, x_n\}$ , replace  $x_k$  with a random number between  $[L_k, U_k]$ , where  $[L_k, U_k]$  are the bounds on the variable  $x_k$ , where the location  $k$  is chosen randomly between 1 and  $n$ . Uniform mutation diversifies the search along a randomly chosen variable within the set of independent variables.

#### A.2.3.2 Boundary Mutation

In many optimization problems, the global optimum value of the objective function lies near the boundary of the search space. The genetic search might miss those boundary optima if the search points become concentrated in the middle of the search space. In order to remedy this problem, Michalewicz *et al.* (1994) introduced the boundary mutation operator. Given a chromosome  $\underline{X} = \{x_1, \dots, x_k, \dots, x_n\}$ , a random location  $k \in \{1, \dots, n\}$  is chosen, then the variable  $x_k$  is replaced with either the minimum or the maximum value of the range of the  $x_k$ . Either boundary is chosen randomly.

#### A.2.3.3 Non-Uniform Mutation

Non-uniform mutation is an operator that starts as a diversifying search element over large spaces around the mutated chromosome in the early stages of the search, and ends up with small variations around the mutated chromosome in the final generations. Boundary mutation is applied as follows: Given a chromosome  $\underline{X} = \{x_1, \dots, x_k, \dots, x_n\}$ , replace  $x_k$  by  $x'_k$  ( $k$  randomly chosen), where:

$$x'_k = \begin{cases} x_k + \Delta(t, U_k - x_k) \\ x_k - \Delta(t, x_k - L_k) \end{cases}$$

Either of the above equations is chosen randomly.

$$\Delta(t, y) = y \cdot r \left( 1 - \frac{t}{T} \right)^6$$

$t$  = The number of the current generation

$T$  = Maximum number of generations

$R$  = Random value between  $[0, 1]$

In the early stages of the search, the value  $[1-t/T]$  is large, and hence large variations from the mutated chromosome can be obtained. This value decays with generations, thus producing small variations.

#### **A.2.3.4 Whole Non-Uniform Mutation**

Given a chromosome  $\underline{X} = \{x_1, \dots, x_n\}$ , apply non-uniform mutation on all variables. This operator diversifies the search along the space of all variables. It is particularly useful in the early stages of the search.

## APPENDIX B: EXAMPLE PARTS MACHINE PROCESSING INFORMATION

Table (B.1) Operations data for part ANC-101.

Feature	Description	Operation	Op. ID	TAD Candidates	Tool Candidates
F1	Planar surface	Milling	OP1	+Z	C6, C7, C8
F2	Planar surface	Milling	OP2	-Z	C6, C7, C8
F3	Four holes arranged as a replicated feature	Drilling	OP3	+Z, -Z	C2
F4	A step	Milling	OP4	+X, -Z	C6, C7
F5	A protrusion (rib)	Milling	OP5	+Y, -Z	C7, C8
F6	A protrusion	Milling	OP6	-Y, -Z	C7, C8
F7	A compound hole	Drilling	OP7	-Z	C2, C3, C4
		Reaming	OP8		C9
		Boring	OP9		C10
F8	Nine holes arranged in a replicated feature	Drilling	OP10	-Z	C1
		Tapping	OP11		C5
F9	A step	Milling	OP12	-X, -Z	C6, C7
F10	Two pockets arranged as a replicated feature	Milling	OP13	+X	C6, C7, C8
F11	A boss	Milling	OP14	-a	C7, C8
F12	A compound hole	Drilling	OP15	-a	C2, C3, C4
		Reaming	OP16		C9
		Boring	OP17		C10
F13	A pocket	Milling	OP18	-X	C7, C8
F14	A compound hole	Reaming	OP19	+Z	C9
		Boring	OP20		C10

Table (B.2) Operations data for part ANC-90.

Feature	Description	Operation	Op. ID	TAD Candidates	Tool Candidates
F1	Planar surface	Milling	OP1	+Z	C6, C7, C8
F2	Planar surface	Milling	OP2	-Z	C6, C7, C8
F3	Four holes arranged as a replicated feature	Drilling	OP3	+Z, -Z	C2
F4	A step	Milling	OP4	+X, -Z	C6, C7
F5	A protrusion (rib)	Milling	OP5	+Y, -Z	C7, C8
F6	A protrusion	Milling	OP6	-Y, -Z	C7, C8
F7	A compound hole	Drilling	OP7	-Z	C2, C3, C4
		Reaming	OP8		C9
		Boring	OP9		C10
F8'	Six holes arranged in a replicated feature	Drilling	OP10'	-Z	C1
		Tapping	OP11'		C5
F9	A step	Milling	OP12	-X, -Z	C6, C7



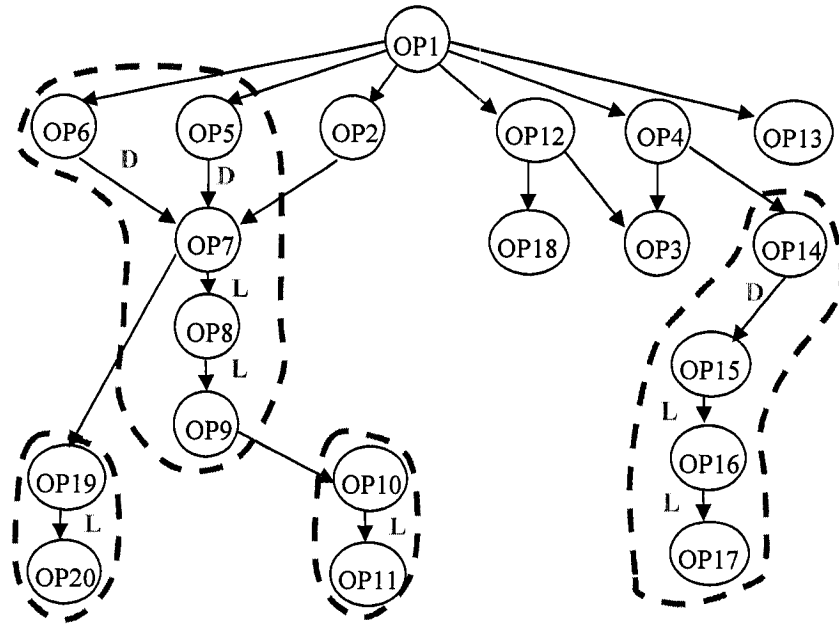

Figure (B.1) Operations precedence graph for part ANC-101.

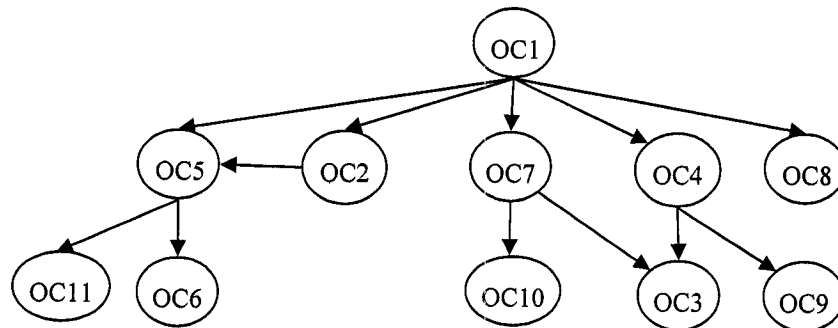

Figure (B.2) Operation clusters precedence graph for part ANC-101.

Table (B.3) Operation clusters definitions for part ANC-101.

Operation Cluster	Operations
OC1	[OP1]
OC2	[OP2]
OC3	[OP3]
OC4	[OP4]
OC5	[OP5, OP6, OP7, OP8, OP9]
OC6	[OP10, OP11]
OC7	[OP12]
OC8	[OP13]
OC9	[OP14, OP15, OP16, OP17]
OC10	[OP18]
OC11	[OP19, OP20]

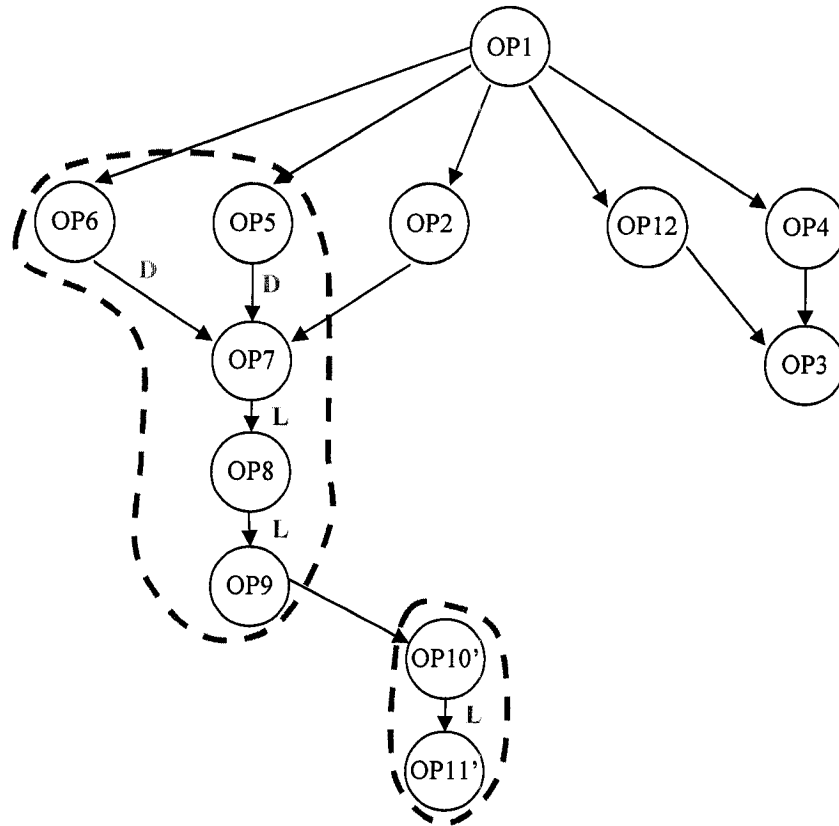

Figure (B.3) Operations precedence graph for part ANC-90.

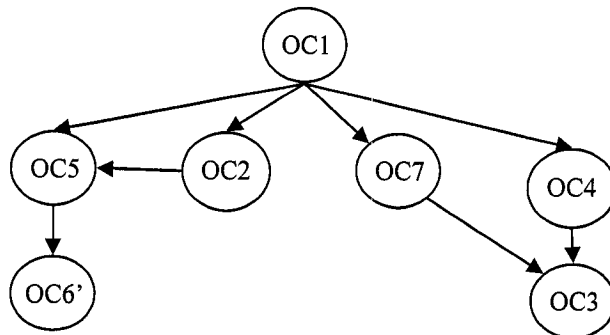

Figure (B.4) Operation clusters precedence graph for part ANC-90.

Table (B.4) Operation clusters definitions for part ANC-90.

Operation Cluster	Operations
OC1	[OP1]
OC2	[OP2]
OC3	[OP3]
OC4	[OP4]
OC5	[OP5, OP6, OP7, OP8, OP9]
OC6'	[OP10', OP11']
OC7	[OP12]

Table (B.5) Available/obtainable resources description and cost.

Machine (M)		Machine Configuration (MC)		Initial Cost (in 1000 of USD)	Steady-State Availability	Number of Removable Modules
Code	Description	Code	Description			
M1	Reconfigurable Horizontal Milling Machine	MC1 <sub>1</sub>	3-axis with 1 spindle	860	0.92	3
		MC1 <sub>2</sub>	3-axis with 2 spindles	1140	0.90	4
		MC1 <sub>3</sub>	3-axis with 3 spindles	1420	0.88	5
		MC1 <sub>4</sub>	3-axis with 4 spindles	1700	0.86	6
		MC1 <sub>5</sub>	4-axis with 1 spindle	1010	0.90	4
M2	Reconfigurable Drilling Press	MC2 <sub>1</sub>	1 spindle	385	0.94	1
		MC2 <sub>2</sub>	2 spindles	555	0.92	2
		MC2 <sub>3</sub>	3 spindles	725	0.90	3
		MC2 <sub>4</sub>	4 spindles	895	0.88	4
M3	Reconfigurable Boring Machine	MC3 <sub>1</sub>	1 spindle	285	0.92	1

Table (B.6) Time and production rate information for different M-MC-OS combinations.

Operation Clusters Setup (OS)		Standard Time in Seconds (Production Rate in Parts/Hour)								
Code	Operation Clusters (OCs)	M1					M2			
		MC1 <sub>1</sub>	MC1 <sub>2</sub>	MC1 <sub>3</sub>	MC1 <sub>4</sub>	MC1 <sub>5</sub>	MC2 <sub>1</sub>	MC2 <sub>2</sub>	MC2 <sub>3</sub>	MC2 <sub>4</sub>
OS1	[OC1]	30 (120)	30 (240)	30 (360)	30 (480)	30 (120)	X	X	X	X
OS2	[OC2]	20 (180)	20 (360)	20 (540)	20 (720)	20 (180)	X	X	X	X
OS3	[OC3]	30 (120)	30 (240)	30 (360)	30 (480)	30 (120)	30 (120)	30 (240)	30 (360)	30 (480)
OS4	[OC4]	20 (180)	20 (360)	20 (540)	20 (720)	20 (180)	X	X	X	X
OS5	[OC5]	X	X	X	X	60 (60)	X	X	X	X
OS6	[OC6]	120 (30)	120 (60)	120 (90)	120 (120)	120 (30)	120 (30)	120 (60)	120 (90)	120 (120)
OS6'	[OC6']	90 (40)	90 (80)	90 (120)	90 (160)	90 (40)	90 (40)	90 (80)	90 (120)	90 (160)
OS7	[OC7]	18 (200)	18 (400)	18 (600)	18 (800)	18 (200)	X	X	X	X
OS8	[OC8]	X	X	X	X	20 (180)	X	X	X	X
OS9	[OC9]	X	X	X	X	40 (90)	X	X	X	X
OS10	[OC10]	X	X	X	X	18 (200)	X	X	X	X
OS11	[OC11]	24 (150)	24 (300)	24 (450)	24 (600)	24 (150)	X	X	X	X
OS12	[OC3, OC11]	60 (60)	60 (120)	60 (180)	60 (240)	60 (60)	X	X	X	X
OS13	[OC8, OC10]	30 (120)	30 (240)	30 (360)	30 (480)	30 (120)	X	X	X	X
OS14	[OC2, OC4, OC7]	40 (90)	40 (180)	40 (270)	40 (360)	40 (90)	X	X	X	X
OS15	[OC2, OC3, OC4, OC7]	60 (60)	60 (120)	60 (180)	60 (240)	60 (60)	X	X	X	X
OS16	[OC2, OC4, OC7, OC8, OC10]	X	X	X	X	60 (60)	X	X	X	X
OS17	[OC2, OC3, OC4, OC7, OC8, OC10]	X	X	X	X	90 (40)	X	X	X	X

## APPENDIX C: TABU SEARCH

This appendix is provided to give a brief idea about the use of basic Tabu Search (TS) and its variants, Reactive Tabu Search (RTS) (Battiti and Tecchiolli 1994), Continuous Reactive Tabu Search (C-RTS) (Battiti and Tecchiolli 1996) and Modified Continuous Reactive Tabu Search (M-C-RTS) (Youssef 2001), in optimization. The description of the basic TS in this appendix (Section C.1) was extracted and summarized from (Glover 1999, Pham and Karaboga 2000).

### C.1 Basic Tabu Search (TS)

TS is a kind of iterative search characterized by the use of a flexible memory. It is able to eliminate local minima and to search areas beyond a local minimum. Therefore, it has the ability to find the global minimum of a multi-modal search space. The process with which TS overcomes the local optimality problem is based on an evaluation function that chooses the highest evaluation solution at each iteration. This means moving to the best admissible solution in the neighborhood of the current solution in terms of the objective value and tabu restrictions. The evaluation function selects the move that produces the most improvement or the least deterioration in the objective function. A tabu list is employed to store the characteristics of accepted moves so that these characteristics can be used to classify certain moves as tabu (i.e. to be avoided) in later iterations. In other words, the tabu list determines which solutions may be reached by a move from the current solution. Since moves not leading to improvements are accepted in TS, it is possible to return to already visited solutions. This might cause a cycling problem to arise. The tabu list is used to overcome this problem. A strategy called the forbidding strategy is employed to control and update the tabu list. By using the forbidding strategy, a path previously visited is avoided and new regions of search space are explored. A description of the basic TS scheme is provided in the following sections.

#### C.1.1 Strategies

A simple TS algorithm consists of three main strategies: forbidding strategy, freeing strategy and short-term strategy. The forbidding strategy controls what enters the tabu

list. The freeing strategy controls what exits the tabu list and when. The short-term strategy manages the interplay between the forbidding and freeing strategies to select trial solutions. Apart from these strategies, there can be also a learning strategy, which consists in the use of intermediate and long-term memory functions. These strategies collect information during a TS run and this information is used to direct the search in subsequent runs.

### **C.1.2 Forbidding Strategy**

This strategy is employed to avoid cycling problems by forbidding certain moves or in other words classifying them as tabu. In order to prevent the cycling problem, it is sufficient to check if a previously visited solution is revisited. Ideally, the tabu list must store all previously visited solutions and before any new move is carried out the list must be checked. However this requires too much memory and computational effort. A simple rule to avoid the cycling problem could be not visiting the solution visited at the last iteration. However, it is clear that this precaution does not guarantee that cycling will not occur. An alternative way might be not visiting the solutions already visited during the last  $T$  iterations (these solutions are stored in the tabu list). Thus by preventing the choice of moves that represent the reversal of any decision taken during a sequence of the last  $T$  iterations, the search moves progressively away from all solutions of the previous  $T$  iteration. Here  $T$  is normally called the tabu list length, tabu list size or prohibition period. With the help of the appropriate value of  $T$ , the likelihood of cycling effectively vanishes. If this value is too small, the probability of cycling is high. If it is too large the search might be driven away from good solutions region before these regions are completely explored.

The tabu list embodies one of the primary short-terms memory functions of TS. As explained above, it is implemented by registering only the  $T$  most recent moves. Once the list is full each new move is written over the oldest move in the list. Effectively the tabu list is processed as a circular array in a first-in-first-out (FIFO) procedure.

### C.1.3 Aspiration Criteria and Tabu Restrictions

An aspiration criterion is used to make a tabu solution free if this solution is of sufficient quality and can prevent cycling. While an aspiration criterion has a role in guiding the search process, tabu restrictions have a role in constraining the search space. A solution is acceptable if the tabu restrictions are satisfied. However, a tabu solution is also assumed acceptable if an aspiration criterion applies regardless of the tabu status. The move attributes are recorded and used in TS to impose constraints that prevent move from being chosen that would reverse the changes represented by these attributes. Tabu restrictions are also used to avoid repetitions rather than reversals. These have the role of preventing the repetition of a search path that leads away from a given solution. By contrast, restrictions that prevent reversals have the rule of preventing a return to a previous solution. A tabu restriction is typically activated only in the case where its attributes occurred within a limited number of iterations prior to the present iteration (a recency-based restriction), or occurred with a certain frequency over a larger number of iterations (a frequency-based restriction). More precisely, a tabu restriction is enforced only when the attributes underlying its definition satisfy certain thresholds of recency or frequency.

In recency-based restriction, a tabu duration is determined and the tabu solution is retained as tabu throughout the tabu duration. Rules for determining the tabu durations are classified as static or dynamic. Static rules choose a value for the duration that remains fixed throughout the search. Dynamic rules allow the value of the tenure to vary.

In frequency-based restriction, a frequency measure is used. The measure is a ratio whose numerator represents the count of the number of occurrences of a particular event and whose denominator generally represents one of the following quantities:

- (a) Sum of numerators
- (b) Maximum numerator value
- (c) Average numerator value

The appropriate use of aspiration criteria can be very significant for enabling TS to achieve its best performance. An aspiration criterion can be either time-independent or time-dependent. Early applications of TS employed only a simple type of aspiration criterion, which is a time-independent criterion. It consists of removing a tabu classification from a trial solution when the solution shows better performance than the best obtained so far. This remains widely used. Another widely used aspiration criterion is aspiration by default. With this criterion, if all available moves are classified as tabu, and are not rendered admissible by another aspiration criteria, then the "least tabu" solution is selected. This could be a solution that loses its tabu classification by the least increase in the value of the present iteration number. Apart from this criterion, there are several other criteria used for aspiration such as aspiration by objective, aspiration by search direction and aspiration by influence.

#### **C.1.4 Freeing Strategy**

The freeing strategy is used to decide what exits the tabu list. The strategy deletes the tabu restrictions of the solution so that they can be reconsidered in further steps of the search. The attributes of a tabu solution remain on the tabu list for a duration of  $T$  iterations. A solution is considered admissible if its attributes are not tabu or if it has passed the aspiration criterion test.

#### **C.1.5 Use of Memory**

The memory used in TS is both explicit and attributive. Explicit memory records complete solutions, typically consisting of elite solutions visited during the search. An extension of this memory records highly attractive but unexplored neighbors of elite solutions. The memorized elite solutions (or their attractive neighbors) are used to expand the local search. Alternatively, TS uses attributive memory for guiding purposes. This type of memory records information about solution attributes that change in moving from one solution to another. This information helps in building the tabu list. Explicit and attributive memories are complementary. While explicit memory expands the neighborhood during local search (by including elite solutions), attributive memory typically reduces it (by selectively screening or forbidding certain moves).



### **C.1.6 Intensification and Diversification**

Two highly important components of Tabu Search are intensification and diversification strategies. Intensification strategies are based on modifying choice rules to encourage move combinations and solution features historically found good. They may also initiate a return to attractive regions to search them more thoroughly. Since elite solutions must be recorded in order to examine their immediate neighborhood, explicit memory is closely related to the implementation of intensification strategies. The main difference between intensification and diversification is that during intensification stage the search focuses on examining neighbors of elite solutions.

Here the term “neighbors” has a broader meaning than in the usual context of “neighborhood search.” That is, in addition to considering solutions that are adjacent or close to elite solutions by means of standard move mechanisms, intensification strategies generate “neighbors” by either grafting together components of good solutions or by using modified evaluations that favor the introduction of such components into a current (evolving) solution.

Intensification strategies require a means for identifying a set of elite solutions as basis for incorporating good attributes into newly created solutions. Membership in the elite set is often determined by setting a threshold that is connected to the objective function value of the best solution found during the search.

The diversification on the other hand encourages the search process to examine unvisited regions and to generate solutions that differ in various significant ways from those seen before.

### **C.1.7 Intermediate and Long-Term Learning Strategies**

These strategies are implemented using intermediate and long-term memory functions. The intermediate function provides an element of intensification. It operates by recording good features of a selected number of moves generated during the execution of the algorithm. This can be considered a learning strategy, which seeks new solutions that

exhibit similar features to those previously recorded. This is achieved by restricting moves that do not possess favorable features.

### C.1.8 Short-Term Strategy (Overall Strategy)

This strategy manages the interplay between the above different strategies. The overall strategy is shown in Figure (C.1). A candidate list is a sub list of the possible moves. Candidate list strategies are generally problem dependent and can be derived by various methods such as random sampling.

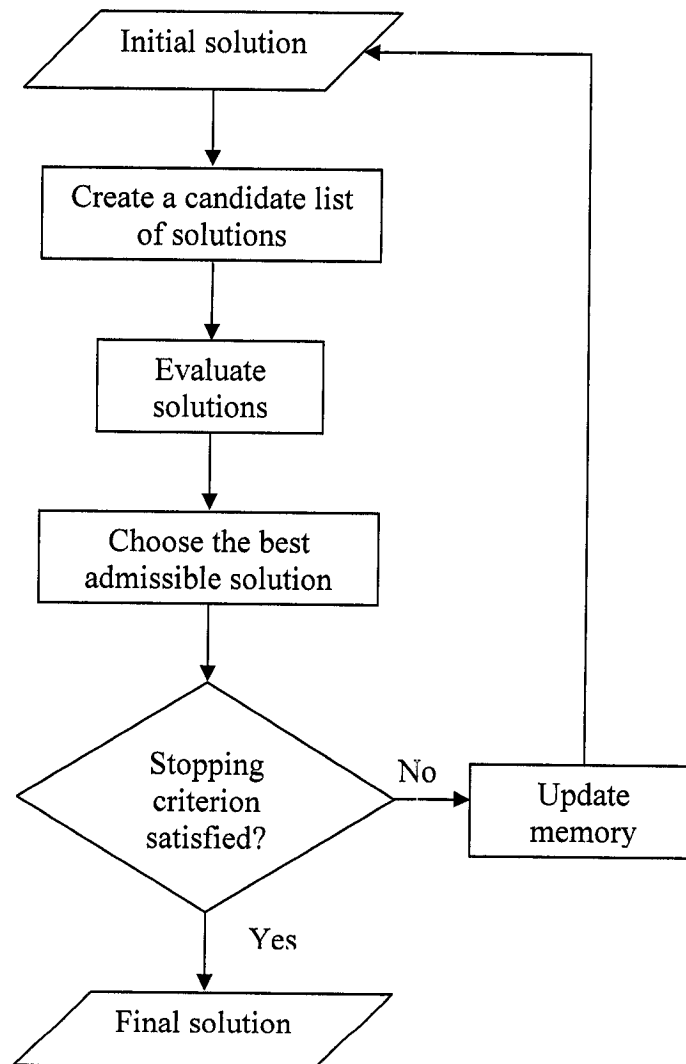

Figure (C.1) Flowchart of a standard TS algorithm.

The best-solution selection strategy selects an admissible solution from the current solution if it yields the greatest improvement or the list deterioration in the objective

function subject to the tabu restrictions and aspiration criterion being satisfied. This is an aggressive criterion and is based on the assumption that solutions with higher evaluations have a higher probability of either leading to a near-optimal solution, or leading to a good solution in a newer number of steps. If a solution satisfies the aspiration criterion it is admissible whether or not it is tabu. If a solution does not satisfy these criteria then it is admissible if it is not tabu.

A stopping criterion terminates the TS procedure after a specified number of iterations have been performed either in total, or since the current best solution was found

## **C.2 Reactive Tabu Search (RTS)**

The Reactive Tabu Search (RTS) (Battiti and Tecchiolli 1994) is based on the idea of dynamic implementation of the intensification and diversification strategies throughout the search process using mechanisms that are function of the search outcomes rather than fixed mechanisms. One of the major challenges in applying the basic TS, described earlier in Section C.1, is the determination of the appropriate size of the prohibition period (tabu list size) that can best suite a specific problem. The RTS solves this problem by devising a mechanism for dynamically resizing the tabu list size according to the search dynamics which is being followed by making use of one of the most distinctive characteristics of TS, which is the use of memory. The tabu list size in RTS increases to achieve diversification in areas of the search where solutions are re-visited more frequently. On the other hand, intensification is performed by decreasing the tabu list size in areas of promising objective function evaluations and where the solutions are re-visited less frequently. In addition, an escape mechanism that performs a number of totally random moves is devised in order to escape from being trapped in large basins of the solution space where the number of frequently visited solutions exceeds a specific limit. RTS was introduced to solve combinatorial (discrete) optimization problems and proved to be very efficient.

### **C.3 Continuous Reactive Tabu Search (C-RTS)**

The Continuous Reactive Tabu Search (C-RTS) (Battiti and Tecchiolli 1996) is a hybrid TS coding scheme that was developed for the global optimization of multi-modal continuous functions where a combinatorial optimization method cooperates with a stochastic local minimizer. The combinatorial component, based on the Reactive Tabu Search (RTS), locates the most promising hyper boxes that represent the combinatorial components in the search space, where starting points for the local minimizer (Affine Shaker) are started. The method is designed with adaptive mechanisms in order to cover a wide spectrum of possible applications with no user intervention. These mechanisms adapt to suit the local properties of the function to be optimized concerning size of the basins of attraction and smoothness of the function in each search region. The hyper box size and level of abstraction depends on the level of intensification or diversification of the search process in the region represented by that box.

### **C.4 Modified Continuous Reactive Tabu Search (M-C-RTS)**

The Modified Continuous Reactive Tabu Search (M-C-RTS) was introduced by Youssef (2001) to improve the original C-RTS for application in continuous domain optimization. The main differences (areas of improvement) are as follows:

- The utilization of the Aspiration Criteria concept presented in (Glover 1999) which is missing in the original C-RTS.
- The use of a pure random local optimizer, Affine Shaker (Battiti and Tecchiolli 1996), is replaced by another more powerful local optimizer, Sequential Quadratic Programming (SQP), which was identified by Rao (1999) as perhaps one of the best methods of optimization.
- The use of the local optimizer, which is costly concerning the number of objective function evaluations, is handled in a more optimized way in order to give way to the combinatorial component to increase its share from the total number of objective function evaluations. This is done by dividing the search process into three stages as follows:

- An initial stage in which the hybrid algorithm is utilized but the SQP runs with low precision just to point out the basins of attraction of the local minima that are stored in a special data structure.
- An intermediate stage in which the SQP runs from promising points that were previously found during the initial stage but have not satisfied the necessary conditions for triggering the local minimizer (SQP). In this stage the SQP runs with same low precision as in the initial stage and the new local minima found are added to those previously found in the initial stage.
- A final stage, which is the most exhaustive stage of the whole search, in which the SQP runs with a very high precision (the precision required for the search) only from some of the stored local minima previously found in the first two stages of the search. The chosen minima are those promising that one of them will lead to the global optimum.

In this way, the handling of the local minimizer (SQP) is optimized and it does not run exhaustively except in promising (deep) basins of attractions.

## APPENDIX D: UNIVERSAL GENERATING FUNCTION

This appendix is provided to give a description of the Universal Generating Function (UGF).

The moment generating functions are often thought of as “transforms” of the density function (or probability function) defining the distribution. They reflect certain properties of distribution functions and could be used to generate moments and cumulants. They also have a particular usefulness in connection with sums of independent random variables. It is possible to evaluate the moments of a probability law, which when available requires the performance of only one summation or integration, after which all the moments of the probability law can be obtained by routine differentiation (Parzen 1967, Patel *et al.* 1976).

For many practical problems, the use of generating function proves to be inappropriate because it is necessary to carry out operations of various kinds other than summation over the corresponding random variables. The Universal Generating Function (U-Function) is a modification of a generating function that was introduced by Ushakov (1986). This function enables the solution of various combinatorial problems. In particular, the Universal Generating Function introduced enables one to solve reliability theoretic problems (calculation of indices of reliability of system consisting of multilevel component). It is convenient for solving a number of problems on a computer.

The Universal Generating Function of the distribution of a discrete random variable  $X$  which can have  $K$  values  $(a_1, a_2, \dots, a_k, \dots, a_K)$ , is the function  $U(Z)$ , defined for all real numbers  $Z$  by

$$U(Z) = \sum_{k=1}^K p_k Z^{a_k} \quad (D.1)$$

Where  $p_k$  is the probability that the random variable  $X$  under consideration takes on the value  $a_k$ , and  $Z$  is the argument of the generating function.

Consider systems described by the so-called reducible structure, i.e., structures that can be represented as a composition of series and parallel connections. A characteristic property of such structures is the fact that, by means of a finite number of equivalent transformations (reductions) of simple series and parallel connections to an equivalent element, these structures can, as a whole, be reduced to a single equivalent element.

To obtain the U-function of a subsystem (component) containing a number of elements, composition operators are introduced. The operators determine the polynomial  $U(Z)$  for a group of elements connected in parallel and in series, respectively, using simple algebraic operations on the individual U-functions. The vital property of the U-Transform enables the total U-function for a multi state system of components connected in parallel or series to be obtained (Ushakov 1986, Ushakov and Harrison 1993).

To obtain steady state probability distributions of the different states of a multi-state system based on the probability distributions of states of its elements (components or units), the operator  $\Omega$  is defined by

$$\Omega_f \left[ \sum_{all\_k} p_k Z^{a_k}, \sum_{all\_i} p_i Z^{a_i} \right] = \sum_{all\_k} \sum_{all\_i} p_k p_i Z^{f(a_k, a_i)} \quad (D.2)$$

The  $f(a_k, a_i)$  is defined according to the physical nature of the multi-state system performance and the interactions between multi-state system elements. It expresses the entire performance rate of a subsystem consisting of two elements connected in parallel or in series in terms of the individual performance rates of its elements.

The composition operators should satisfy the following conditions for arbitrary  $k$ ,

1)

$$\begin{aligned} & \Omega[U_1(Z), \dots, U_k(Z), U_{k+1}(Z), \dots, U_n(Z)] \\ & = \Omega[U_1(Z), \dots, U_{k+1}(Z), U_k(Z), \dots, U_n(Z)] \end{aligned} \quad (D.3)$$

2)

$$\begin{aligned} & \Omega[\Omega[U_1(Z), \dots, U_k(Z)], \Omega[U_{k+1}(Z), \dots, U_n(Z)]] \\ & = \Omega[U_1(Z), \dots, U_k(Z), U_{k+1}(Z), \dots, U_n(Z)] \end{aligned} \quad (D.4)$$



where  $n$  is the number of elements in the system under construction.

Let  $\sigma$  be the structure function for series connection of elements and  $\pi$  the corresponding structure function for parallel connection (Ushakov 1986). To calculate the U-function for a multi state system containing:

- 1)  $n$  elements in series, the  $\sigma$  operator is used

$$U(Z) = \sigma[U_1(Z), U_2(Z), \dots, U_n(Z)], \quad (D.5)$$

- 2)  $n$  elements in parallel, the  $\pi$  operator is used

$$U(Z) = \pi[U_1(Z), U_2(Z), \dots, U_n(Z)], \quad (D.6)$$

where  $U_i(Z)$  = individual U-function of element  $i$ .

Composition operators  $\sigma$  and  $\pi$  are special cases of  $\Omega$ , which can be defined according to the type of multi state system. Two important multi state system types are considered. Type-1 uses capacity of elements as the performance measure while type-2 uses operation time as the performance measure (Levitin and Lisnianski 1999b).

Examples of **type-1** multi state system are power systems, energy or materials continuous flow systems, and manufacturing systems. The performance level for each element can be characterized by its capacity.

For elements in series, the element with the minimal capacity becomes the system bottleneck. Therefore this element defines the system capacity. If there are two elements #1 and #2 in series, then:

$$\sigma_1 \left[ \sum_{all\_k} p_k Z^{a_k}, \sum_{all\_i} p_i Z^{a_i} \right] = \sum_{all\_k} \sum_{all\_i} p_k p_i Z^{\min(a_k, a_i)}. \quad (D.7)$$

Parameters  $a_k, a_i$  are physically interpreted as the capacities of elements 1 and 2, respectively,  $k, i$  are indices of possible capacity levels for elements 1 and 2,  $p_k, p_i$  are steady state probabilities of possible capacity levels for elements 1 and 2, respectively as described before.

For elements in parallel, the system total capacity is the sum of the capacities of all its elements. For example, in power system elements the total capacity of 2 generators connected in parallel in the power system is the sum of their individual capacities. Therefore, if there are 2 elements connected in parallel, then:

$$\pi_1 \left[ \sum_{all\_k} p_k Z^{a_k}, \sum_{all\_i} p_i Z^{a_i} \right] = \sum_{all\_k} \sum_{all\_i} p_k p_i Z^{(a_k + a_i)}, \quad (D.8)$$

where the  $\pi_1$  is simply a product of the individual U-functions of system elements.

The **type-2 systems** are represented by multi-state system for which the performance measure is characterized by the operation time. This category includes control systems, information or data processing systems, manufacturing systems with constrained operation time, etc. It is useful to express the operation time  $\tau_s$  by using its processing speed  $a = 1/\tau_s$ .

For two elements 1 and 2 in series, the  $\tau_s$  is the sum of element operation times ( $1/a + 1/b$ ), where  $a, b$  are the processing speeds of elements 1 and 2 respectively.

The  $\tau_s^{-1} = (1/a + 1/b)^{-1}$ . Therefore,

$$\sigma_2 \left[ \sum_{all\_k} p_k Z^{a_k}, \sum_{all\_i} p_i Z^{a_i} \right] = \sum_{all\_k} \sum_{all\_i} p_k p_i Z^{(1/a_k + 1/a_i)^{-1}}, \quad (D.9)$$

where parameters  $a_k, a_i$  are physically interpreted as the processing speeds of elements 1 and 2, respectively.  $k, i$  are indices of possible processing speed levels for elements 1 and 2,  $p_k, p_i$  are steady state probabilities of possible processing speed levels for elements 1 and 2, respectively.

The total system performance for two elements 1 and 2 in parallel is the sum ( $a+b$ ) of the processing speeds of the elements. For example, if two parallel processors are solving the problem simultaneously, sharing the work in proportion to there processing speed, the total system operation time is:

$$\tau_s = 1/(a + b). \quad (D.10)$$

Hence, for elements 1 and 2 in parallel:

$$\pi_2 \left[ \sum_{all\_k} p_k Z^{a_k}, \sum_{all\_i} p_i Z^{a_i} \right] = \sum_{all\_k} \sum_{all\_i} p_k p_i Z^{(a_k + a_i)} \quad (D.11)$$

Evidently, a successive application of procedures  $\sigma$  and  $\pi$  reduces any reducible structure to some equivalent element. Consequently applying composition operators one can obtain the U-function of the entire multi state system in the form

$$U(Z) = \sum_{all\_k} p_k Z^{a_k} \quad (D.12)$$

# APPENDIX E: A SAMPLE RESULTS REPORT

## RMS-Configurator Results Report

### Symbols:

S: Stage Number  
SL: Stage Location  
M: Machine Type  
MC: Machine Configuration  
NMS: Number of Machines per Stage  
OSi: Operation Cluster Setup assigned for part number i

### System Space Limitations:

The number of available stage locations (maximum number of stages) = 10  
The maximum number of parallel machines per stage = 8

### System Investment Limitation:

The maximum allowable initial investment in the configuration (machines, axes, spindles and fixtures) = 60 million US Dollars

The depreciation rate for the equipment used in the configuration = 10%  
The yearly interest rate = 12%

The original configuration (C0) was as follows:

S(SL)	1(3)	2(4)	3(5)	4(6)	5(7)	6(8)
M	1	1	1	2	2	1
MC	5	3	5	3	1	2
NMS	4	6	5	2	6	2
OS1	1	14	5	61	3	0
OS2	9	5	13	6	3	11

### 1. The First Stage:

This stage of the approach targeted optimizing the capital cost and the system availability of configurations that are capable of meeting the requirements of each anticipated demand scenario (DS) in each configuration period (CP) within the planning horizon of the system regardless of the level of smoothness of the reconfiguration process from one configuration to the next.

Steady-state availability of different M-MC combinations is considered and it is assumed that there is no buffer capacity between production stages.

The optimization method used in the first stage is "Real-Coded Genetic Algorithms" with the following parameters:

Population size = 200

Number of generations = 700

Number of times to apply uniform mutation = 12

Number of times to apply boundary mutation = 12

Number of times to apply non-uniform mutation = 12

Number of times to apply whole arithmetic cross-over = 6

Number of times to apply simple arithmetic cross-over = 6

Number of times to apply whole non-uniform mutation = 12

Number of times to apply heuristic cross-over = 6

Parameter for non uniform mutation = 6  
 Parameter for simple cross-over = 10  
 Q = 0.1

The maximum number of candidate near-optimal configurations generated for each DS is 10.

The maximum tolerance limit for the candidate configurations compared to their best configuration is 5%.

The demand scenarios of each CP and the corresponding outcomes of the first stage of the approach (near-optimal candidate configurations and their corresponding objective function evaluations) are as follows:

The number of configuration periods (NCP) = 5

1.1 Configuration Period 1 (CP1):

The duration of CP1 = 1.5 years

CP1 has the following deterministic demand scenario:

The number of part types = 2

1- Part type 1 is to be produced with a rate of 120 parts/hour.

2- Part type 2 is to be produced with a rate of 180 parts/hour.

The first stage of the approach produced 10 near-optimal candidate configurations for CP1 in a duration of 1.9 hours. The configurations are as follows:

1- Configuration #1 for CP1:

S(SL)	1(1)	2(2)	3(3)	4(4)	5(5)	6(6)	7(7)
M	1	1	1	1	1	1	2
MC	2	3	4	5	2	5	2
NMS	3	3	2	7	2	4	6
OS1	1	0	14	5	0	3	61
OS2	1	15	13	5	11	9	6

Capital cost of the configuration in present value = 7.7746 million US Dollars

Initial investment in the configuration = 27.8000 million US Dollars

Reconfiguration smoothness (RS) value of the configuration from C0 = 0.29731

System availability of the configuration = 74.161%

System expected production rate of the configuration for part type 1 = 341 parts/hour

System expected production rate of the configuration for part type 2 = 280 parts/hour

System utilization of the configuration = 99.3%

Overall utility function evaluation of the configuration = 7774.84334

2- Configuration #2 for CP1:

S(SL)	1(1)	2(2)	3(3)	4(4)	5(5)	6(6)	7(7)
M	1	1	1	1	1	1	2
MC	1	3	4	5	2	5	2
NMS	4	3	2	7	2	4	6
OS1	1	0	14	5	0	3	61
OS2	1	15	13	5	11	9	6

Capital cost of the configuration in present value = 7.7802 million US Dollars  
 Initial investment in the configuration = 27.8200 million US Dollars  
 Reconfiguration smoothness (RS) value of the configuration from C0 = 0.29645  
 System availability of the configuration = 73.671%  
 System expected production rate of the configuration for part type 1 = 338 parts/hour  
 System expected production rate of the configuration for part type 2 = 280 parts/hour  
 System utilization of the configuration = 99.8%  
 Overall utility function evaluation of the configuration = 7780.44147

3- Configuration #3 for CP1:

S(SL)	1(1)	2(2)	3(3)	4(4)	5(5)	6(6)	7(7)
M	1	1	1	1	1	1	2
MC	2	3	2	5	2	5	2
NMS	3	3	3	7	2	4	6
OS1	1	0	14	5	0	3	61
OS2	1	15	13	5	11	9	6

Capital cost of the configuration in present value = 7.7802 million US Dollars  
 Initial investment in the configuration = 27.8200 million US Dollars  
 Reconfiguration smoothness (RS) value of the configuration from C0 = 0.29392  
 System availability of the configuration = 73.526%  
 System expected production rate of the configuration for part type 1 = 343 parts/hour  
 System expected production rate of the configuration for part type 2 = 284 parts/hour  
 System utilization of the configuration = 98.3%  
 Overall utility function evaluation of the configuration = 7780.44292

4- Configuration #4 for CP1:

S(SL)	1(1)	2(2)	3(3)	4(4)	5(5)	6(6)	7(7)
M	1	1	1	1	1	1	2
MC	2	3	4	5	2	5	4
NMS	3	3	2	7	2	4	4
OS1	1	0	14	5	0	3	61
OS2	1	15	13	5	11	9	6

Capital cost of the configuration in present value = 7.8445 million US Dollars  
 Initial investment in the configuration = 28.0500 million US Dollars  
 Reconfiguration smoothness (RS) value of the configuration from C0 = 0.30927  
 System availability of the configuration = 74.490%  
 System expected production rate of the configuration for part type 1 = 343 parts/hour  
 System expected production rate of the configuration for part type 2 = 288 parts/hour  
 System utilization of the configuration = 97.5%  
 Overall utility function evaluation of the configuration = 7844.75539

5- Configuration #5 for CP1:

S(SL)	1(1)	2(2)	3(3)	4(4)	5(5)	6(6)	7(7)
-------	------	------	------	------	------	------	------

M	1	1	1	1	1	1	2
MC	2	3	4	5	2	5	3
NMS	3	3	2	7	2	4	5
OS1	1	0	14	5	0	3	61
OS2	1	15	13	5	11	9	6

Capital cost of the configuration in present value = 7.8571 million US Dollars

Initial investment in the configuration = 28.0950 million US Dollars  
Reconfiguration smoothness (RS) value of the configuration from C0 = 0.30450

System availability of the configuration = 79.148%

System expected production rate of the configuration for part type 1 = 345 parts/hour

System expected production rate of the configuration for part type 2 = 290 parts/hour

System utilization of the configuration = 96.9%

Overall utility function evaluation of the configuration = 7857.29357

6- Configuration #6 for CP1:

S(SL)	1(1)	2(2)	3(3)	4(4)	5(5)	6(6)	7(7)
M	1	1	1	1	1	1	2
MC	2	3	4	5	2	5	3
NMS	3	3	2	6	2	5	5
OS1	1	0	14	5	0	3	61
OS2	1	15	13	5	11	9	6

Capital cost of the configuration in present value = 7.8571 million US Dollars

Initial investment in the configuration = 28.0950 million US Dollars  
Reconfiguration smoothness (RS) value of the configuration from C0 = 0.30430

System availability of the configuration = 74.404%

System expected production rate of the configuration for part type 1 = 314 parts/hour

System expected production rate of the configuration for part type 2 = 292 parts/hour

System utilization of the configuration = 99.9%

Overall utility function evaluation of the configuration = 7857.34100

7- Configuration #7 for CP1:

S(SL)	1(1)	2(2)	3(3)	4(4)	5(5)	6(6)	7(7)
M	1	1	1	1	1	1	2
MC	2	3	4	5	2	5	3
NMS	3	3	2	6	2	5	5
OS1	1	14	0	5	0	3	61
OS2	1	15	13	5	11	9	6

Capital cost of the configuration in present value = 7.8571 million US Dollars

Initial investment in the configuration = 28.0950 million US Dollars  
Reconfiguration smoothness (RS) value of the configuration from C0 = 0.30430

System availability of the configuration = 74.404%

System expected production rate of the configuration for part type 1 = 317 parts/hour



System expected production rate of the configuration for part type 2 = 292 parts/hour  
 System utilization of the configuration = 99.5%  
 Overall utility function evaluation of the configuration = 7857.34100

8- Configuration #8 for CP1:

S(SL)	1(1)	2(2)	3(3)	4(4)	5(5)	6(6)	7(7)
M	1	1	1	1	1	1	2
MC	2	3	4	5	1	5	2
NMS	3	3	2	7	3	4	6
OS1	1	0	14	5	0	3	61
OS2	1	15	13	5	11	9	6

Capital cost of the configuration in present value = 7.8585 million US Dollars

Initial investment in the configuration = 28.1000 million US Dollars

Reconfiguration smoothness (RS) value of the configuration from C0 = 0.29491

System availability of the configuration = 73.549%

System expected production rate of the configuration for part type 1 = 341 parts/hour

System expected production rate of the configuration for part type 2 = 280 parts/hour

System utilization of the configuration = 99.4%

Overall utility function evaluation of the configuration = 7858.74786

9- Configuration #9 for CP1:

S(SL)	1(1)	2(2)	3(3)	4(4)	5(5)	6(6)	7(7)
M	1	1	1	1	1	1	2
MC	2	2	4	5	2	5	2
NMS	3	4	2	7	2	4	6
OS1	1	0	14	5	0	3	61
OS2	1	15	13	5	11	9	6

Capital cost of the configuration in present value = 7.8585 million US Dollars

Initial investment in the configuration = 28.1000 million US Dollars

Reconfiguration smoothness (RS) value of the configuration from C0 = 0.29843

System availability of the configuration = 73.192%

System expected production rate of the configuration for part type 1 = 341 parts/hour

System expected production rate of the configuration for part type 2 = 282 parts/hour

System utilization of the configuration = 99.0%

Overall utility function evaluation of the configuration = 7858.75144

10- Configuration #10 for CP1:

S(SL)	1(1)	2(2)	3(3)	4(4)	5(5)	6(6)	7(7)
M	1	1	1	1	1	1	2
MC	2	3	2	5	2	5	3
NMS	3	3	3	6	2	5	5
OS1	1	0	14	5	0	3	61
OS2	1	15	13	5	11	9	6

Capital cost of the configuration in present value = 7.8627 million US Dollars

Initial investment in the configuration = 28.1150 million US Dollars  
 Reconfiguration smoothness (RS) value of the configuration from C0 = 0.30086  
 System availability of the configuration = 73.767%  
 System expected production rate of the configuration for part type 1 = 316 parts/hour  
 System expected production rate of the configuration for part type 2 = 296 parts/hour  
 System utilization of the configuration = 98.9%  
 Overall utility function evaluation of the configuration = 7862.94061

1.2 Configuration period 2 (CP2):

The duration of CP2 = 1.0 years  
 The number of demand scenarios in CP2 = 2

1.2.1 Demand scenario #1 in CP2 (DS21):

The probability of occurrence of DS21 in CP2 = 60%  
 The number of part types = 1

1- Part type 1 is to be produced with a rate of 220 parts/hour.

The first stage of the approach produced 10 near-optimal candidate configurations for DS21 in a duration of 21.8 minutes. The configurations are as follows:

1- Configuration #1 for DS21:

S	1	2	3	4
M	1	1	1	2
MC	3	3	5	4
NMS	2	2	5	2
OS1	1	15	5	61

Capital cost of the configuration in present value = 2.4593 million US Dollars

Initial investment in the configuration = 12.5200 million US Dollars  
 System availability of the configuration = 54.291%  
 System expected production rate of the configuration for part type 1 = 221 parts/hour  
 System utilization of the configuration = 99.4%  
 Overall utility function evaluation of the configuration = 2459.74280

2- Configuration #2 for DS21:

S	1	2	3	4
M	1	1	1	2
MC	1	4	5	4
NMS	3	2	5	2
OS1	1	15	5	61

Capital cost of the configuration in present value = 2.5182 million US Dollars

Initial investment in the configuration = 12.8200 million US Dollars  
 System availability of the configuration = 68.470%  
 System expected production rate of the configuration for part type 1 = 225 parts/hour  
 System utilization of the configuration = 97.7%  
 Overall utility function evaluation of the configuration = 2518.52959

3- Configuration #3 for DS21:

S	1	2	3	4
M	1	1	1	2
MC	2	3	5	4
NMS	2	2	5	3
OS1	1	15	5	61

Capital cost of the configuration in present value = 2.5251 million US Dollars

Initial investment in the configuration = 12.8550 million US Dollars

System availability of the configuration = 67.622%

System expected production rate of the configuration for part type 1 = 236 parts/hour

System utilization of the configuration = 93.2%

Overall utility function evaluation of the configuration = 2525.41307

4- Configuration #4 for DS21:

S	1	2	3	4
M	1	1	1	2
MC	3	3	5	3
NMS	2	2	5	3
OS1	1	15	5	61

Capital cost of the configuration in present value = 2.5349 million US Dollars

Initial investment in the configuration = 12.9050 million US Dollars

System availability of the configuration = 68.144%

System expected production rate of the configuration for part type 1 = 233 parts/hour

System utilization of the configuration = 94.3%

Overall utility function evaluation of the configuration = 2535.22927

5- Configuration #5 for DS21:

S	1	2	3	4
M	1	1	1	2
MC	3	3	5	2
NMS	2	2	5	4
OS1	1	15	5	61

Capital cost of the configuration in present value = 2.5438 million US Dollars

Initial investment in the configuration = 12.9500 million US Dollars

System availability of the configuration = 67.694%

System expected production rate of the configuration for part type 1 = 234 parts/hour

System utilization of the configuration = 94.2%

Overall utility function evaluation of the configuration = 2544.07306

6- Configuration #6 for DS21:

S	1	2	3	4
M	1	1	1	2
MC	3	4	5	4
NMS	2	2	5	2
OS1	1	15	5	61

Capital cost of the configuration in present value = 2.5693 million US Dollars

Initial investment in the configuration = 13.0800 million US Dollars



System availability of the configuration = 68.733%  
 System expected production rate of the configuration for part type 1 = 228 parts/hour  
 System utilization of the configuration = 96.4%  
 Overall utility function evaluation of the configuration = 2569.59838

7- Configuration #7 for DS21:

S	1	2	3	4
M	1	1	1	2
MC	4	3	5	4
NMS	2	2	5	2
OS1	1	15	5	61

Capital cost of the configuration in present value = 2.5693 million US Dollars

Initial investment in the configuration = 13.0800 million US Dollars

System availability of the configuration = 54.005%

System expected production rate of the configuration for part type 1 = 220 parts/hour

System utilization of the configuration = 100.0%

Overall utility function evaluation of the configuration = 2569.74567

8- Configuration #8 for DS21:

S	1	2	3	4
M	1	1	1	2
MC	3	3	5	2
NMS	1	2	6	5
OS1	1	15	5	61

Capital cost of the configuration in present value = 2.5722 million US Dollars

Initial investment in the configuration = 13.0950 million US Dollars

System availability of the configuration = 66.764%

System expected production rate of the configuration for part type 1 = 247 parts/hour

System utilization of the configuration = 89.2%

Overall utility function evaluation of the configuration = 2572.56451

9- Configuration #9 for DS21:

S	1	2	3	4
M	1	1	1	2
MC	3	2	5	4
NMS	2	3	5	2
OS1	1	15	5	61

Capital cost of the configuration in present value = 2.5732 million US Dollars

Initial investment in the configuration = 13.1000 million US Dollars

System availability of the configuration = 68.144%

System expected production rate of the configuration for part type 1 = 229 parts/hour

System utilization of the configuration = 96.0%

Overall utility function evaluation of the configuration = 2573.53284

10- Configuration #10 for DS21:

S	1	2	3	4
M	1	1	1	2

MC	2	3	5	4
NMS	3	2	5	2
OS1	1	15	5	61

Capital cost of the configuration in present value = 2.5732 million US Dollars

Initial investment in the configuration = 13.1000 million US Dollars

System availability of the configuration = 55.029%

System expected production rate of the configuration for part type 1 = 224 parts/hour

System utilization of the configuration = 98.3%

Overall utility function evaluation of the configuration = 2573.66399

1.2.2 Demand scenario #2 in CP2 (DS22):

The probability of occurrence of DS22 in CP2 = 40%

The number of part types = 2

1- Part type 1 is to be produced with a rate of 180 parts/hour.

2- Part type 2 is to be produced with a rate of 120 parts/hour.

The first stage of the approach produced 9 near-optimal candidate configurations for DS22 in a duration of 1.1 hours. The configurations are as follows:

1- Configuration #1 for DS22:

S	1	2	3	4	5	6	7
M	1	1	1	1	2	1	1
MC	3	3	5	5	3	3	3
NMS	2	3	4	7	4	2	2
OS1	1	15	0	5	61	0	0
OS2	1	14	9	5	6	13	12

Capital cost of the configuration in present value = 5.2623 million US Dollars

Initial investment in the configuration = 26.7900 million US Dollars

System availability of the configuration = 59.022%

System expected production rate of the configuration for part type 1 = 341 parts/hour

System expected production rate of the configuration for part type 2 = 256 parts/hour

System utilization of the configuration = 99.5%

Overall utility function evaluation of the configuration = 5262.73121

2- Configuration #2 for DS22:

S	1	2	3	4	5	6	7
M	1	1	1	1	2	1	1
MC	3	3	5	5	3	3	3
NMS	2	3	4	7	4	2	2
OS1	1	15	0	5	61	0	0
OS2	1	14	9	5	6	12	13

Capital cost of the configuration in present value = 5.2623 million US Dollars

Initial investment in the configuration = 26.7900 million US Dollars

System availability of the configuration = 59.022%

System expected production rate of the configuration for part type 1 = 341 parts/hour

System expected production rate of the configuration for part type 2 = 256 parts/hour  
 System utilization of the configuration = 99.5%  
 Overall utility function evaluation of the configuration = 5262.73121

3- Configuration #3 for DS22:

S	1	2	3	4	5	6	7
M	1	1	1	1	2	1	1
MC	3	3	5	5	3	3	2
NMS	2	3	4	7	4	2	3
OS1	1	15	0	5	61	0	0
OS2	1	14	9	5	6	13	12

Capital cost of the configuration in present value = 5.3763 million US Dollars

Initial investment in the configuration = 27.3700 million US Dollars

System availability of the configuration = 72.872%

System expected production rate of the configuration for part type 1 = 341 parts/hour

System expected production rate of the configuration for part type 2 = 265 parts/hour

System utilization of the configuration = 98.0%

Overall utility function evaluation of the configuration = 5376.52128

4- Configuration #4 for DS22:

S	1	2	3	4	5	6	7
M	1	1	1	1	2	1	1
MC	3	3	5	5	3	1	3
NMS	2	3	4	7	4	4	2
OS1	1	15	0	5	61	0	0
OS2	1	14	9	5	6	13	12

Capital cost of the configuration in present value = 5.3802 million US Dollars

Initial investment in the configuration = 27.3900 million US Dollars

System availability of the configuration = 59.642%

System expected production rate of the configuration for part type 1 = 341 parts/hour

System expected production rate of the configuration for part type 2 = 258 parts/hour

System utilization of the configuration = 99.2%

Overall utility function evaluation of the configuration = 5380.58215

5- Configuration #5 for DS22:

S	1	2	3	4	5	6	7
M	1	1	1	1	2	1	1
MC	3	3	5	5	3	3	3
NMS	2	3	4	7	5	2	2
OS1	1	15	0	5	61	0	0
OS2	1	14	9	5	6	13	12

Capital cost of the configuration in present value = 5.4047 million US Dollars

Initial investment in the configuration = 27.5150 million US Dollars

System availability of the configuration = 63.110%

System expected production rate of the configuration for part type 1 = 350 parts/hour

System expected production rate of the configuration for part type 2 = 269 parts/hour  
 System utilization of the configuration = 95.9%  
 Overall utility function evaluation of the configuration = 5405.10104

6- Configuration #6 for DS22:

S	1	2	3	4	5	6	7
M	1	1	1	1	2	1	1
MC	3	3	5	5	3	3	3
NMS	2	3	4	7	5	2	2
OS1	1	15	0	5	61	0	0
OS2	1	14	9	5	6	12	13

Capital cost of the configuration in present value = 5.4047 million US Dollars  
 Initial investment in the configuration = 27.5150 million US Dollars  
 System availability of the configuration = 63.110%  
 System expected production rate of the configuration for part type 1 = 350 parts/hour  
 System expected production rate of the configuration for part type 2 = 269 parts/hour  
 System utilization of the configuration = 95.9%  
 Overall utility function evaluation of the configuration = 5405.10104

7- Configuration #7 for DS22:

S	1	2	3	4	5	6	7
M	1	1	1	1	2	1	1
MC	3	3	5	5	3	3	4
NMS	2	3	4	7	5	2	2
OS1	1	15	0	5	61	0	0
OS2	1	14	9	5	6	13	12

Capital cost of the configuration in present value = 5.5147 million US Dollars  
 Initial investment in the configuration = 28.0750 million US Dollars  
 System availability of the configuration = 78.220%  
 System expected production rate of the configuration for part type 1 = 350 parts/hour  
 System expected production rate of the configuration for part type 2 = 277 parts/hour  
 System utilization of the configuration = 94.7%  
 Overall utility function evaluation of the configuration = 5514.94995

8- Configuration #8 for DS22:

S	1	2	3	4	5	6	7
M	1	1	1	1	2	1	1
MC	3	3	5	5	3	1	3
NMS	2	3	4	7	5	4	2
OS1	1	15	0	5	61	0	0
OS2	1	14	9	5	6	13	12

Capital cost of the configuration in present value = 5.5226 million US Dollars  
 Initial investment in the configuration = 28.1150 million US Dollars  
 System availability of the configuration = 63.731%  
 System expected production rate of the configuration for part type 1 = 350 parts/hour



System expected production rate of the configuration for part type 2 = 271 parts/hour  
 System utilization of the configuration = 95.6%  
 Overall utility function evaluation of the configuration = 5522.95198

9- Configuration #9 for DS22:

S	1	2	3	4	5	6	7
M	1	1	1	1	2	1	1
MC	1	3	5	5	3	3	3
NMS	4	3	4	7	5	2	2
OS1	1	15	0	5	61	0	0
OS2	1	14	9	5	6	13	12

Capital cost of the configuration in present value = 5.5226 million US Dollars

Initial investment in the configuration = 28.1150 million US Dollars

System availability of the configuration = 61.828%

System expected production rate of the configuration for part type 1 = 350 parts/hour

System expected production rate of the configuration for part type 2 = 271 parts/hour

System utilization of the configuration = 95.6%

Overall utility function evaluation of the configuration = 5522.97101

1.3 Configuration period 3 (CP3):

The duration of CP3 = 1.2 years

The number of demand scenarios in CP3 = 3

1.3.1 Demand scenario #1 in CP3 (DS31):

The probability of occurrence of DS31 in CP3 = 50%

The number of part types = 2

1- Part type 1 is to be produced with a rate of 120 parts/hour.

2- Part type 2 is to be produced with a rate of 180 parts/hour.

The first stage of the approach produced 10 near-optimal candidate configurations for DS31 in a duration of 1.2 hours. The configurations are as follows:

1- Configuration #1 for DS31:

S	1	2	3	4	5	6	7	8
M	1	1	1	2	1	2	1	1
MC	3	3	5	1	5	4	2	3
NMS	2	2	7	4	4	4	2	2
OS1	1	2	5	0	7	61	4	3
OS2	1	14	5	3	9	6	11	13

Capital cost of the configuration in present value = 6.2390 million US Dollars

Initial investment in the configuration = 27.0300 million US Dollars

System availability of the configuration = 74.884%

System expected production rate of the configuration for part type 1 = 340 parts/hour

System expected production rate of the configuration for part type 2 = 279 parts/hour

System utilization of the configuration = 99.9%

Overall utility function evaluation of the configuration = 6239.24870

2- Configuration #2 for DS31:

S	1	2	3	4	5	6	7	8
M	1	1	1	2	1	2	1	1
MC	3	3	5	2	5	4	2	3
NMS	2	2	7	3	4	4	2	2
OS1	1	2	5	0	7	61	4	3
OS2	1	14	5	3	9	6	11	13

Capital cost of the configuration in present value = 6.2678 million US Dollars

Initial investment in the configuration = 27.1550 million US Dollars

System availability of the configuration = 75.016%

System expected production rate of the configuration for part type 1 = 340 parts/hour

System expected production rate of the configuration for part type 2 = 279 parts/hour

System utilization of the configuration = 99.9%

Overall utility function evaluation of the configuration = 6268.09956

3- Configuration #3 for DS31:

S	1	2	3	4	5	6	7	8
M	1	1	1	2	1	2	1	1
MC	3	3	5	2	5	3	2	3
NMS	2	2	7	3	4	5	2	2
OS1	1	2	5	0	7	61	4	3
OS2	1	14	5	3	9	6	11	13

Capital cost of the configuration in present value = 6.2782 million US Dollars

Initial investment in the configuration = 27.2000 million US Dollars

System availability of the configuration = 79.815%

System expected production rate of the configuration for part type 1 = 342 parts/hour

System expected production rate of the configuration for part type 2 = 280 parts/hour

System utilization of the configuration = 99.3%

Overall utility function evaluation of the configuration = 6278.43837

4- Configuration #4 for DS31:

S	1	2	3	4	5	6	7	8
M	1	1	1	2	1	2	1	1
MC	3	3	5	1	5	4	2	3
NMS	2	2	7	5	4	4	2	2
OS1	1	2	5	0	7	61	4	3
OS2	1	14	5	3	9	6	11	13

Capital cost of the configuration in present value = 6.3279 million US Dollars

Initial investment in the configuration = 27.4150 million US Dollars

System availability of the configuration = 76.255%

System expected production rate of the configuration for part type 1 = 340 parts/hour

System expected production rate of the configuration for part type 2 = 280 parts/hour

System utilization of the configuration = 99.7%

Overall utility function evaluation of the configuration = 6328.09974

5- Configuration #5 for DS31:

S	1	2	3	4	5	6	7	8
M	1	1	1	2	1	2	1	1
MC	3	3	5	2	5	2	2	3
NMS	2	2	7	3	4	7	2	2
OS1	1	2	5	0	7	61	4	3
OS2	1	14	5	3	9	6	11	13

Capital cost of the configuration in present value = 6.3382 million US Dollars

Initial investment in the configuration = 27.4600 million US Dollars

System availability of the configuration = 79.807%

System expected production rate of the configuration for part type 1 = 343 parts/hour

System expected production rate of the configuration for part type 2 = 281 parts/hour

System utilization of the configuration = 99.0%

Overall utility function evaluation of the configuration = 6338.45100

6- Configuration #6 for DS31:

S	1	2	3	4	5	6	7	8
M	1	1	1	2	1	2	1	1
MC	3	3	5	2	5	4	2	3
NMS	2	2	7	4	4	4	2	2
OS1	1	2	5	0	7	61	4	3
OS2	1	14	5	3	9	6	11	13

Capital cost of the configuration in present value = 6.3960 million US Dollars

Initial investment in the configuration = 27.7100 million US Dollars

System availability of the configuration = 76.258%

System expected production rate of the configuration for part type 1 = 340 parts/hour

System expected production rate of the configuration for part type 2 = 280 parts/hour

System utilization of the configuration = 99.7%

Overall utility function evaluation of the configuration = 6396.19087

7- Configuration #7 for DS31:

S	1	2	3	4	5	6	7	8
M	1	1	1	2	1	2	1	1
MC	3	4	5	2	5	4	2	3
NMS	2	2	7	3	4	4	2	2
OS1	1	2	5	0	7	61	4	3
OS2	1	14	5	3	9	6	11	13

Capital cost of the configuration in present value = 6.3971 million US Dollars

Initial investment in the configuration = 27.7150 million US Dollars

System availability of the configuration = 76.116%

System expected production rate of the configuration for part type 1 = 338 parts/hour

System expected production rate of the configuration for part type 2 = 286 parts/hour

System utilization of the configuration = 98.5%

Overall utility function evaluation of the configuration = 6397.34638

8- Configuration #8 for DS31:

S	1	2	3	4	5	6	7	8
M	1	1	1	2	1	2	1	1
MC	3	3	5	2	5	4	3	3
NMS	2	2	7	3	4	4	2	2
OS1	1	2	5	0	7	61	4	3
OS2	1	14	5	3	9	6	11	13

Capital cost of the configuration in present value = 6.3971 million US Dollars

Initial investment in the configuration = 27.7150 million US Dollars

System availability of the configuration = 74.683%

System expected production rate of the configuration for part type 1 = 341 parts/hour

System expected production rate of the configuration for part type 2 = 282 parts/hour

System utilization of the configuration = 99.1%

Overall utility function evaluation of the configuration = 6397.36071

9- Configuration #9 for DS31:

S	1	2	3	4	5	6	7	8
M	1	1	1	2	1	2	1	1
MC	3	2	5	2	5	4	2	3
NMS	2	3	7	3	4	4	2	2
OS1	1	2	5	0	7	61	4	3
OS2	1	14	5	3	9	6	11	13

Capital cost of the configuration in present value = 6.4017 million US Dollars

Initial investment in the configuration = 27.7350 million US Dollars

System availability of the configuration = 75.464%

System expected production rate of the configuration for part type 1 = 344 parts/hour

System expected production rate of the configuration for part type 2 = 288 parts/hour

System utilization of the configuration = 97.4%

Overall utility function evaluation of the configuration = 6401.96925

10- Configuration #10 for DS31:

S	1	2	3	4	5	6	7	8
M	1	1	1	2	1	2	1	1
MC	2	3	5	2	5	4	2	3
NMS	3	2	7	3	4	4	2	2
OS1	1	2	5	0	7	61	4	3
OS2	1	14	5	3	9	6	11	13

Capital cost of the configuration in present value = 6.4017 million US Dollars

Initial investment in the configuration = 27.7350 million US Dollars

System availability of the configuration = 73.981%

System expected production rate of the configuration for part type 1 = 345 parts/hour

System expected production rate of the configuration for part type 2 = 281 parts/hour

System utilization of the configuration = 98.9%

Overall utility function evaluation of the configuration = 6401.98408

### 1.3.2 Demand scenario #2 in CP3 (DS32):

The probability of occurrence of DS32 in CP3 = 30%

The number of part types = 2

1- Part type 1 is to be produced with a rate of 180 parts/hour.

2- Part type 2 is to be produced with a rate of 180 parts/hour.

The first stage of the approach produced 10 near-optimal candidate configurations for DS32 in a duration of 1.3 hours. The configurations are as follows:

#### 1- Configuration #1 for DS32:

S	1	2	3	4	5	6	7
M	1	1	1	1	1	1	2
MC	3	4	5	3	5	3	3
NMS	2	2	7	3	8	2	6
OS1	0	0	1	15	5	0	61
OS2	1	14	5	12	9	13	6

Capital cost of the configuration in present value = 7.5800 million US Dollars

Initial investment in the configuration = 32.8400 million US Dollars

System availability of the configuration = 77.024%

System expected production rate of the configuration for part type 1 = 400 parts/hour

System expected production rate of the configuration for part type 2 = 332 parts/hour

System utilization of the configuration = 99.2%

Overall utility function evaluation of the configuration = 7580.27709

#### 2- Configuration #2 for DS32:

S	1	2	3	4	5	6	7
M	1	1	1	1	1	1	2
MC	3	2	5	3	5	3	3
NMS	2	3	7	3	8	2	6
OS1	0	0	1	15	5	0	61
OS2	1	14	5	12	9	13	6

Capital cost of the configuration in present value = 7.5847 million US Dollars

Initial investment in the configuration = 32.8600 million US Dollars

System availability of the configuration = 76.364%

System expected production rate of the configuration for part type 1 = 400 parts/hour

System expected production rate of the configuration for part type 2 = 334 parts/hour

System utilization of the configuration = 98.9%

Overall utility function evaluation of the configuration = 7584.90004

#### 3- Configuration #3 for DS32:

S	1	2	3	4	5	6	7
M	1	1	1	1	1	1	2
MC	3	4	5	3	5	3	2
NMS	2	2	7	3	8	2	8
OS1	0	0	1	15	5	0	61
OS2	1	14	5	12	9	13	6

Capital cost of the configuration in present value = 7.6008 million US Dollars  
 Initial investment in the configuration = 32.9300 million US Dollars  
 System availability of the configuration = 76.613%  
 System expected production rate of the configuration for part type 1 = 400 parts/hour  
 System expected production rate of the configuration for part type 2 = 332 parts/hour  
 System utilization of the configuration = 99.2%  
 Overall utility function evaluation of the configuration = 7601.05477

4- Configuration #4 for DS32:

S	1	2	3	4	5	6	7
M	1	1	1	1	1	1	2
MC	3	4	5	3	5	3	4
NMS	2	2	7	3	8	2	5
OS1	0	0	1	15	5	0	61
OS2	1	14	5	12	9	13	6

Capital cost of the configuration in present value = 7.6089 million US Dollars  
 Initial investment in the configuration = 32.9650 million US Dollars  
 System availability of the configuration = 77.144%  
 System expected production rate of the configuration for part type 1 = 399 parts/hour  
 System expected production rate of the configuration for part type 2 = 332 parts/hour  
 System utilization of the configuration = 99.3%  
 Overall utility function evaluation of the configuration = 7609.12808

5- Configuration #5 for DS32:

S	1	2	3	4	5	6	7
M	1	1	1	1	1	1	2
MC	3	4	5	3	5	3	4
NMS	2	2	8	3	8	2	4
OS1	0	0	1	15	5	0	61
OS2	1	14	5	12	9	13	6

Capital cost of the configuration in present value = 7.6354 million US Dollars  
 Initial investment in the configuration = 33.0800 million US Dollars  
 System availability of the configuration = 79.538%  
 System expected production rate of the configuration for part type 1 = 393 parts/hour  
 System expected production rate of the configuration for part type 2 = 338 parts/hour  
 System utilization of the configuration = 99.0%  
 Overall utility function evaluation of the configuration = 7635.64815

6- Configuration #6 for DS32:

S	1	2	3	4	5	6	7
M	1	1	1	1	1	1	2
MC	3	4	5	3	5	3	3
NMS	2	2	8	3	8	2	5
OS1	0	0	1	15	5	0	61
OS2	1	14	5	12	9	13	6



Capital cost of the configuration in present value = 7.6458 million US Dollars  
 Initial investment in the configuration = 33.1250 million US Dollars  
 System availability of the configuration = 78.827%  
 System expected production rate of the configuration for part type 1 = 396 parts/hour  
 System expected production rate of the configuration for part type 2 = 337 parts/hour  
 System utilization of the configuration = 98.9%  
 Overall utility function evaluation of the configuration = 7646.04205

7- Configuration #7 for DS32:

S	1	2	3	4	5	6	7
M	1	1	1	1	1	1	2
MC	3	4	5	2	5	3	3
NMS	2	2	7	4	8	2	6
OS1	0	0	1	15	5	0	61
OS2	1	14	5	12	9	13	6

Capital cost of the configuration in present value = 7.6493 million US Dollars  
 Initial investment in the configuration = 33.1400 million US Dollars  
 System availability of the configuration = 75.934%  
 System expected production rate of the configuration for part type 1 = 399 parts/hour  
 System expected production rate of the configuration for part type 2 = 333 parts/hour  
 System utilization of the configuration = 99.2%  
 Overall utility function evaluation of the configuration = 7649.53324

8- Configuration #8 for DS32:

S	1	2	3	4	5	6	7
M	1	1	1	1	1	1	2
MC	3	2	5	3	5	3	3
NMS	2	3	8	3	8	2	5
OS1	0	0	1	15	5	0	61
OS2	1	14	5	12	9	13	6

Capital cost of the configuration in present value = 7.6504 million US Dollars  
 Initial investment in the configuration = 33.1450 million US Dollars  
 System availability of the configuration = 78.150%  
 System expected production rate of the configuration for part type 1 = 396 parts/hour  
 System expected production rate of the configuration for part type 2 = 339 parts/hour  
 System utilization of the configuration = 98.6%  
 Overall utility function evaluation of the configuration = 7650.66517

9- Configuration #9 for DS32:

S	1	2	3	4	5	6	7
M	1	1	1	1	1	1	2
MC	3	4	5	2	5	3	4
NMS	2	2	7	4	8	2	5
OS1	0	0	1	15	5	0	61
OS2	1	14	5	12	9	13	6





Capital cost of the configuration in present value = 7.6781 million US Dollars  
 Initial investment in the configuration = 33.2650 million US Dollars  
 System availability of the configuration = 76.052%  
 System expected production rate of the configuration for part type 1 = 398 parts/hour  
 System expected production rate of the configuration for part type 2 = 333 parts/hour  
 System utilization of the configuration = 99.3%  
 Overall utility function evaluation of the configuration = 7678.38425

10- Configuration #10 for DS32:

S	1	2	3	4	5	6	7
M	1	1	1	1	1	1	2
MC	3	4	5	3	5	3	2
NMS	2	2	8	3	8	2	7
OS1	0	0	1	15	5	0	61
OS2	1	14	5	12	9	13	6

Capital cost of the configuration in present value = 7.7058 million US Dollars  
 Initial investment in the configuration = 33.3850 million US Dollars  
 System availability of the configuration = 76.765%  
 System expected production rate of the configuration for part type 1 = 397 parts/hour  
 System expected production rate of the configuration for part type 2 = 335 parts/hour  
 System utilization of the configuration = 99.0%  
 Overall utility function evaluation of the configuration = 7706.07522

1.3.3 Demand scenario #3 in CP3 (DS33):

The probability of occurrence of DS33 in CP3 = 20%

The number of part types = 1

1- Part type 2 is to be produced with a rate of 200 parts/hour.

The first stage of the approach produced 10 near-optimal candidate configurations for DS33 in a duration of 30.5 minutes. The configurations are as follows:

1- Configuration #1 for DS33:

S	1	2	3	4	5	6
M	1	1	1	1	2	1
MC	2	5	5	5	2	1
NMS	2	7	3	5	5	2
OS1	1	17	9	5	6	11

Capital cost of the configuration in present value = 5.0607 million US Dollars  
 Initial investment in the configuration = 21.9250 million US Dollars  
 System availability of the configuration = 51.696%  
 System expected production rate of the configuration for part type 2 = 200 parts/hour  
 System utilization of the configuration = 99.9%  
 Overall utility function evaluation of the configuration = 5061.15714

2- Configuration #2 for DS33:

S	1	2	3	4	5	6
---	---	---	---	---	---	---

M	1	1	1	1	2	1
MC	2	5	5	5	3	1
NMS	2	7	3	5	4	2
OS1	1	17	9	5	6	11

Capital cost of the configuration in present value = 5.0895 million US Dollars

Initial investment in the configuration = 22.0500 million US Dollars

System availability of the configuration = 51.809%

System expected production rate of the configuration for part type 2 = 201 parts/hour

System utilization of the configuration = 99.3%

Overall utility function evaluation of the configuration = 5090.00821

3- Configuration #3 for DS33:

S	1	2	3	4	5	6
M	1	1	1	1	2	1
MC	2	5	5	5	3	1
NMS	2	7	3	5	3	3
OS1	1	17	9	5	6	11

Capital cost of the configuration in present value = 5.1207 million US Dollars

Initial investment in the configuration = 22.1850 million US Dollars

System availability of the configuration = 46.229%

System expected production rate of the configuration for part type 2 = 200 parts/hour

System utilization of the configuration = 99.8%

Overall utility function evaluation of the configuration = 5121.22437

4- Configuration #4 for DS33:

S	1	2	3	4	5	6
M	1	1	1	1	2	1
MC	1	5	5	5	2	1
NMS	3	7	3	5	5	2
OS1	1	17	9	5	6	11

Capital cost of the configuration in present value = 5.1299 million US Dollars

Initial investment in the configuration = 22.2250 million US Dollars

System availability of the configuration = 51.269%

System expected production rate of the configuration for part type 2 = 201 parts/hour

System utilization of the configuration = 99.7%

Overall utility function evaluation of the configuration = 5130.40667

5- Configuration #5 for DS33:

S	1	2	3	4	5	6
M	1	1	1	1	2	1
MC	2	5	5	5	2	1
NMS	2	7	3	5	6	2
OS1	1	17	9	5	6	11

Capital cost of the configuration in present value = 5.1888 million US Dollars

Initial investment in the configuration = 22.4800 million US Dollars

System availability of the configuration = 54.203%

System expected production rate of the configuration for part type 2 = 203 parts/hour  
 System utilization of the configuration = 98.6%  
 Overall utility function evaluation of the configuration = 5189.23580

6- Configuration #6 for DS33:

S	1	2	3	4	5	6
M	1	1	1	1	2	1
MC	2	5	5	5	2	2
NMS	2	7	3	5	5	2
OS1	1	17	9	5	6	11

Capital cost of the configuration in present value = 5.1899 million US Dollars

Initial investment in the configuration = 22.4850 million US Dollars

System availability of the configuration = 60.467%

System expected production rate of the configuration for part type 2 = 209 parts/hour

System utilization of the configuration = 95.7%

Overall utility function evaluation of the configuration = 5190.32725

7- Configuration #7 for DS33:

S	1	2	3	4	5	6
M	1	1	1	1	2	1
MC	2	5	5	5	4	1
NMS	2	7	3	5	4	2
OS1	1	17	9	5	6	11

Capital cost of the configuration in present value = 5.2465 million US Dollars

Initial investment in the configuration = 22.7300 million US Dollars

System availability of the configuration = 54.324%

System expected production rate of the configuration for part type 2 = 203 parts/hour

System utilization of the configuration = 98.7%

Overall utility function evaluation of the configuration = 5246.93897

8- Configuration #8 for DS33:

S	1	2	3	4	5	6
M	1	1	1	1	2	1
MC	2	5	5	5	3	1
NMS	2	7	3	5	5	2
OS1	1	17	9	5	6	11

Capital cost of the configuration in present value = 5.2569 million US Dollars

Initial investment in the configuration = 22.7750 million US Dollars

System availability of the configuration = 54.200%

System expected production rate of the configuration for part type 2 = 203 parts/hour

System utilization of the configuration = 98.4%

Overall utility function evaluation of the configuration = 5257.32700

9- Configuration #9 for DS33:

S	1	2	3	4	5	6
M	1	1	1	1	2	1
MC	2	5	5	5	2	1

NMS	2	7	3	5	5	3
OS1	1	17	9	5	6	11

Capital cost of the configuration in present value = 5.2592 million US Dollars

Initial investment in the configuration = 22.7850 million US Dollars

System availability of the configuration = 59.968%

System expected production rate of the configuration for part type 2 = 210 parts/hour

System utilization of the configuration = 95.3%

Overall utility function evaluation of the configuration = 5259.57750

10- Configuration #10 for DS33:

S	1	2	3	4	5	6
M	1	1	1	1	1	2
MC	2	5	5	2	5	1
NMS	2	6	5	3	3	8
OS1	1	16	5	12	9	6

Capital cost of the configuration in present value = 5.2903 million US Dollars

Initial investment in the configuration = 22.9200 million US Dollars

System availability of the configuration = 58.394%

System expected production rate of the configuration for part type 2 = 202 parts/hour

System utilization of the configuration = 98.9%

Overall utility function evaluation of the configuration = 5290.75359

1.4 Configuration period 4 (CP4):

The duration of CP4 = 1.5 years

The number of demand scenarios in CP4 = 2

1.4.1 Demand scenario #1 in CP4 (DS41):

The probability of occurrence of DS41 in CP4 = 50%

The number of part types = 1

1- Part type 2 is to be produced with a rate of 220 parts/hour.

The first stage of the approach produced 10 near-optimal candidate configurations for DS41 in a duration of 30.3 minutes. The configurations are as follows:

1- Configuration #1 for DS41:

S	1	2	3	4	5	6
M	1	1	1	1	2	1
MC	2	5	5	5	2	3
NMS	2	5	4	5	6	2
OS1	1	16	9	5	6	12

Capital cost of the configuration in present value = 6.3175 million US Dollars

Initial investment in the configuration = 22.5900 million US Dollars

System availability of the configuration = 60.779%

System expected production rate of the configuration for part type 2 = 220 parts/hour

System utilization of the configuration = 99.8%

Overall utility function evaluation of the configuration = 6317.94163

2- Configuration #2 for DS41:

S	1	2	3	4	5	6
M	1	1	1	1	2	1
MC	2	5	5	5	2	2
NMS	2	5	4	5	5	3
OS1	1	16	9	5	6	12

Capital cost of the configuration in present value = 6.3245 million US Dollars

Initial investment in the configuration = 22.6150 million US Dollars

System availability of the configuration = 72.760%

System expected production rate of the configuration for part type 2 = 225 parts/hour

System utilization of the configuration = 97.8%

Overall utility function evaluation of the configuration = 6324.81336

3- Configuration #3 for DS41:

S	1	2	3	4	5	6
M	1	1	1	1	2	1
MC	2	5	5	5	4	3
NMS	2	5	4	5	4	2
OS1	1	16	9	5	6	12

Capital cost of the configuration in present value = 6.3875 million US Dollars

Initial investment in the configuration = 22.8400 million US Dollars

System availability of the configuration = 60.915%

System expected production rate of the configuration for part type 2 = 220 parts/hour

System utilization of the configuration = 99.9%

Overall utility function evaluation of the configuration = 6387.85560

4- Configuration #4 for DS41:

S	1	2	3	4	5	6
M	1	1	1	1	2	1
MC	2	5	5	5	3	3
NMS	2	5	4	5	5	2
OS1	1	16	9	5	6	12

Capital cost of the configuration in present value = 6.4000 million US Dollars

Initial investment in the configuration = 22.8850 million US Dollars

System availability of the configuration = 60.776%

System expected production rate of the configuration for part type 2 = 221 parts/hour

System utilization of the configuration = 99.6%

Overall utility function evaluation of the configuration = 6400.44176

5- Configuration #5 for DS41:

S	1	2	3	4	5	6
M	1	1	1	1	2	1
MC	1	5	5	5	2	3
NMS	3	5	4	5	6	2
OS1	1	16	9	5	6	12

Capital cost of the configuration in present value = 6.4014 million US Dollars



Initial investment in the configuration = 22.8900 million US Dollars  
 System availability of the configuration = 60.277%  
 System expected production rate of the configuration for part type 2 = 220 parts/hour  
 System utilization of the configuration = 99.8%  
 Overall utility function evaluation of the configuration = 6401.84505

6- Configuration #6 for DS41:

S	1	2	3	4	5	6
M	1	1	1	1	2	1
MC	2	5	5	5	4	3
NMS	2	6	4	5	3	2
OS1	1	16	9	5	6	12

Capital cost of the configuration in present value = 6.4196 million US Dollars

Initial investment in the configuration = 22.9550 million US Dollars  
 System availability of the configuration = 63.069%  
 System expected production rate of the configuration for part type 2 = 221 parts/hour  
 System utilization of the configuration = 99.6%  
 Overall utility function evaluation of the configuration = 6419.99512

7- Configuration #7 for DS41:

S	1	2	3	4	5	6
M	1	1	1	1	2	1
MC	2	5	5	5	4	3
NMS	2	5	4	6	3	2
OS1	1	16	9	5	6	12

Capital cost of the configuration in present value = 6.4196 million US Dollars

Initial investment in the configuration = 22.9550 million US Dollars  
 System availability of the configuration = 63.069%  
 System expected production rate of the configuration for part type 2 = 221 parts/hour  
 System utilization of the configuration = 99.6%  
 Overall utility function evaluation of the configuration = 6419.99512

8- Configuration #8 for DS41:

S	1	2	3	4	5	6
M	1	1	1	1	2	1
MC	2	5	5	5	2	3
NMS	2	6	4	5	5	2
OS1	1	16	9	5	6	12

Capital cost of the configuration in present value = 6.4448 million US Dollars

Initial investment in the configuration = 23.0450 million US Dollars  
 System availability of the configuration = 62.109%  
 System expected production rate of the configuration for part type 2 = 222 parts/hour  
 System utilization of the configuration = 99.1%  
 Overall utility function evaluation of the configuration = 6445.17424

9- Configuration #9 for DS41:

S	1	2	3	4	5	6
---	---	---	---	---	---	---



M	1	1	1	1	2	1
MC	2	5	5	5	2	3
NMS	2	5	4	6	5	2
OS1	1	16	9	5	6	12

Capital cost of the configuration in present value = 6.4448 million US Dollars

Initial investment in the configuration = 23.0450 million US Dollars

System availability of the configuration = 62.109%

System expected production rate of the configuration for part type 2 = 222 parts/hour

System utilization of the configuration = 99.1%

Overall utility function evaluation of the configuration = 6445.17424

10- Configuration #10 for DS41:

S	1	2	3	4	5	6
M	1	1	1	1	2	1
MC	1	5	5	5	4	3
NMS	3	5	4	5	4	2
OS1	1	16	9	5	6	12

Capital cost of the configuration in present value = 6.4714 million US Dollars

Initial investment in the configuration = 23.1400 million US Dollars

System availability of the configuration = 60.412%

System expected production rate of the configuration for part type 2 = 220 parts/hour

System utilization of the configuration = 99.9%

Overall utility function evaluation of the configuration = 6471.75903

1.4.2 Demand scenario #2 in CP4 (DS42):

The probability of occurrence of DS42 in CP4 = 50%

The number of part types = 2

1- Part type 1 is to be produced with a rate of 120 parts/hour.

2- Part type 2 is to be produced with a rate of 120 parts/hour.

The first stage of the approach produced 10 near-optimal candidate configurations for DS42 in a duration of 1.1 hours. The configurations are as follows:

1- Configuration #1 for DS42:

S	1	2	3	4	5	6
M	1	1	1	2	1	1
MC	2	5	5	2	5	3
NMS	2	6	6	5	3	2
OS1	1	15	5	61	0	0
OS2	1	16	5	6	9	12

Capital cost of the configuration in present value = 6.4448 million US Dollars

Initial investment in the configuration = 23.0450 million US Dollars

System availability of the configuration = 57.121%

System expected production rate of the configuration for part type 1 = 282 parts/hour

System expected production rate of the configuration for part type 2 = 210 parts/hour

System utilization of the configuration = 99.6%



Overall utility function evaluation of the configuration = 6445.22412

2- Configuration #2 for DS42:

S	1	2	3	4	5	6
M	1	1	1	2	1	1
MC	2	5	5	3	5	3
NMS	2	6	6	4	3	2
OS1	1	15	5	61	0	0
OS2	1	16	5	6	9	12

Capital cost of the configuration in present value = 6.4798 million US Dollars

Initial investment in the configuration = 23.1700 million US Dollars

System availability of the configuration = 59.831%

System expected production rate of the configuration for part type 1 = 284 parts/hour

System expected production rate of the configuration for part type 2 = 214 parts/hour

System utilization of the configuration = 98.4%

Overall utility function evaluation of the configuration = 6480.15469

3- Configuration #3 for DS42:

S	1	2	3	4	5	6
M	1	1	1	2	1	1
MC	1	5	5	2	5	3
NMS	3	6	6	5	3	2
OS1	1	15	5	61	0	0
OS2	1	16	5	6	9	12

Capital cost of the configuration in present value = 6.5287 million US Dollars

Initial investment in the configuration = 23.3450 million US Dollars

System availability of the configuration = 56.469%

System expected production rate of the configuration for part type 1 = 280 parts/hour

System expected production rate of the configuration for part type 2 = 211 parts/hour

System utilization of the configuration = 99.8%

Overall utility function evaluation of the configuration = 6529.12904

4- Configuration #4 for DS42:

S	1	2	3	4	5	6
M	1	1	1	2	1	1
MC	1	5	5	3	5	3
NMS	3	6	6	4	3	2
OS1	1	15	5	61	0	0
OS2	1	16	5	6	9	12

Capital cost of the configuration in present value = 6.5637 million US Dollars

Initial investment in the configuration = 23.4700 million US Dollars

System availability of the configuration = 59.078%

System expected production rate of the configuration for part type 1 = 283 parts/hour

System expected production rate of the configuration for part type 2 = 214 parts/hour

System utilization of the configuration = 98.7%

Overall utility function evaluation of the configuration = 6564.06062

5- Configuration #5 for DS42:

S	1	2	3	4	5	6
M	1	1	1	2	1	1
MC	2	5	5	2	5	3
NMS	2	6	6	6	3	2
OS1	1	15	5	61	0	0
OS2	1	16	5	6	9	12

Capital cost of the configuration in present value = 6.6000 million US Dollars

Initial investment in the configuration = 23.6000 million US Dollars

System availability of the configuration = 61.976%

System expected production rate of the configuration for part type 1 = 286 parts/hour

System expected production rate of the configuration for part type 2 = 215 parts/hour

System utilization of the configuration = 97.7%

Overall utility function evaluation of the configuration = 6600.38761

6- Configuration #6 for DS42:

S	1	2	3	4	5	6
M	1	1	1	2	1	1
MC	2	5	5	2	5	4
NMS	2	6	6	5	3	2
OS1	1	15	5	61	0	0
OS2	1	16	5	6	9	12

Capital cost of the configuration in present value = 6.6014 million US Dollars

Initial investment in the configuration = 23.6050 million US Dollars

System availability of the configuration = 68.398%

System expected production rate of the configuration for part type 1 = 282 parts/hour

System expected production rate of the configuration for part type 2 = 217 parts/hour

System utilization of the configuration = 97.8%

Overall utility function evaluation of the configuration = 6601.72170

7- Configuration #7 for DS42:

S	1	2	3	4	5	6
M	1	1	1	2	1	1
MC	3	5	5	2	5	3
NMS	2	6	6	5	3	2
OS1	1	15	5	61	0	0
OS2	1	16	5	6	9	12

Capital cost of the configuration in present value = 6.6014 million US Dollars

Initial investment in the configuration = 23.6050 million US Dollars

System availability of the configuration = 58.180%

System expected production rate of the configuration for part type 1 = 291 parts/hour

System expected production rate of the configuration for part type 2 = 211 parts/hour

System utilization of the configuration = 98.1%

Overall utility function evaluation of the configuration = 6601.82387

8- Configuration #8 for DS42:

S	1	2	3	4	5	6
M	1	1	1	2	1	1
MC	2	5	5	2	5	2
NMS	2	6	6	5	3	3
OS1	1	15	5	61	0	0
OS2	1	16	5	6	9	12

Capital cost of the configuration in present value = 6.6070 million US Dollars

Initial investment in the configuration = 23.6250 million US Dollars

System availability of the configuration = 67.812%

System expected production rate of the configuration for part type 1 = 282 parts/hour

System expected production rate of the configuration for part type 2 = 219 parts/hour

System utilization of the configuration = 97.5%

Overall utility function evaluation of the configuration = 6607.32078

9- Configuration #9 for DS42:

S	1	2	3	4	5	6
M	1	1	1	2	1	1
MC	2	5	5	3	5	4
NMS	2	6	6	4	3	2
OS1	1	15	5	61	0	0
OS2	1	16	5	6	9	12

Capital cost of the configuration in present value = 6.6364 million US Dollars

Initial investment in the configuration = 23.7300 million US Dollars

System availability of the configuration = 70.112%

System expected production rate of the configuration for part type 1 = 284 parts/hour

System expected production rate of the configuration for part type 2 = 220 parts/hour

System utilization of the configuration = 96.7%

Overall utility function evaluation of the configuration = 6636.66222

10- Configuration #10 for DS42:

S	1	2	3	4	5	6
M	1	1	1	2	1	1
MC	3	5	5	3	5	3
NMS	2	6	6	4	3	2
OS1	1	15	5	61	0	0
OS2	1	16	5	6	9	12

Capital cost of the configuration in present value = 6.6364 million US Dollars

Initial investment in the configuration = 23.7300 million US Dollars

System availability of the configuration = 61.452%

System expected production rate of the configuration for part type 1 = 294 parts/hour

System expected production rate of the configuration for part type 2 = 215 parts/hour

System utilization of the configuration = 96.7%

Overall utility function evaluation of the configuration = 6636.74882

1.5 Configuration period 5 (CP5):

The duration of CP5 = 1.3 years

The number of demand scenarios in CP5 = 4

1.5.1 Demand scenario #1 in CP5 (DS51):

The probability of occurrence of DS51 in CP5 = 40%

The number of part types = 2

1- Part type 1 is to be produced with a rate of 150 parts/hour.

2- Part type 2 is to be produced with a rate of 150 parts/hour.

The first stage of the approach produced 10 near-optimal candidate configurations for DS51 in a duration of 1.2 hours. The configurations are as follows:

1- Configuration #1 for DS51:

S	1	2	3	4	5	6	7
M	1	1	1	2	1	2	1
MC	3	5	5	3	5	3	2
NMS	2	7	4	2	7	4	2
OS1	1	15	0	0	5	61	0
OS2	1	16	9	3	5	6	11

Capital cost of the configuration in present value = 6.8422 million US Dollars

Initial investment in the configuration = 27.6500 million US Dollars

System availability of the configuration = 72.137%

System expected production rate of the configuration for part type 1 = 336 parts/hour

System expected production rate of the configuration for part type 2 = 276 parts/hour

System utilization of the configuration = 98.9%

Overall utility function evaluation of the configuration = 6842.44013

2- Configuration #2 for DS51:

S	1	2	3	4	5	6	7
M	1	1	1	2	1	2	1
MC	3	5	5	1	5	3	2
NMS	2	7	4	4	7	4	2
OS1	1	15	0	0	5	61	0
OS2	1	16	9	3	5	6	11

Capital cost of the configuration in present value = 6.8644 million US Dollars

Initial investment in the configuration = 27.7400 million US Dollars

System availability of the configuration = 71.623%

System expected production rate of the configuration for part type 1 = 336 parts/hour

System expected production rate of the configuration for part type 2 = 278 parts/hour

System utilization of the configuration = 98.6%

Overall utility function evaluation of the configuration = 6864.71632

3- Configuration #3 for DS51:

S	1	2	3	4	5	6	7
M	1	1	1	2	1	2	1

MC	3	5	5	2	5	3	2
NMS	2	7	4	3	7	4	2
OS1	1	15	0	0	5	61	0
OS2	1	16	9	3	5	6	11

Capital cost of the configuration in present value = 6.8954 million US Dollars

Initial investment in the configuration = 27.8650 million US Dollars

System availability of the configuration = 71.733%

System expected production rate of the configuration for part type 1 = 336 parts/hour

System expected production rate of the configuration for part type 2 = 278 parts/hour

System utilization of the configuration = 98.5%

Overall utility function evaluation of the configuration = 6895.64723

4- Configuration #4 for DS51:

S	1	2	3	4	5	6	7
M	1	1	1	2	1	2	1
MC	3	5	5	3	5	3	1
NMS	2	7	4	2	7	4	3
OS1	1	15	0	0	5	61	0
OS2	1	16	9	3	5	6	11

Capital cost of the configuration in present value = 6.9164 million US Dollars

Initial investment in the configuration = 27.9500 million US Dollars

System availability of the configuration = 71.541%

System expected production rate of the configuration for part type 1 = 336 parts/hour

System expected production rate of the configuration for part type 2 = 276 parts/hour

System utilization of the configuration = 98.9%

Overall utility function evaluation of the configuration = 6916.68292

5- Configuration #5 for DS51:

S	1	2	3	4	5	6	7
M	1	1	1	2	1	2	1
MC	3	5	5	4	5	3	2
NMS	2	7	4	2	7	4	2
OS1	1	15	0	0	5	61	0
OS2	1	16	9	3	5	6	11

Capital cost of the configuration in present value = 6.9263 million US Dollars

Initial investment in the configuration = 27.9900 million US Dollars

System availability of the configuration = 71.816%

System expected production rate of the configuration for part type 1 = 336 parts/hour

System expected production rate of the configuration for part type 2 = 275 parts/hour

System utilization of the configuration = 99.1%

Overall utility function evaluation of the configuration = 6926.57842

6- Configuration #6 for DS51:

S	1	2	3	4	5	6	7
M	1	1	1	2	1	2	1



MC	3	5	5	3	5	2	2
NMS	2	7	4	2	7	6	2
OS1	1	15	0	0	5	61	0
OS2	1	16	9	3	5	6	11

Capital cost of the configuration in present value = 6.9486 million US Dollars

Initial investment in the configuration = 28.0800 million US Dollars

System availability of the configuration = 74.306%

System expected production rate of the configuration for part type 1 = 341 parts/hour

System expected production rate of the configuration for part type 2 = 282 parts/hour

System utilization of the configuration = 97.2%

Overall utility function evaluation of the configuration = 6948.82457

7- Configuration #7 for DS51:

S	1	2	3	4	5	6	7
M	1	1	1	2	1	2	1
MC	3	5	5	1	5	3	2
NMS	2	7	4	5	7	4	2
OS1	1	15	0	0	5	61	0
OS2	1	16	9	3	5	6	11

Capital cost of the configuration in present value = 6.9597 million US Dollars

Initial investment in the configuration = 28.1250 million US Dollars

System availability of the configuration = 72.742%

System expected production rate of the configuration for part type 1 = 336 parts/hour

System expected production rate of the configuration for part type 2 = 279 parts/hour

System utilization of the configuration = 98.4%

Overall utility function evaluation of the configuration = 6959.97573

8- Configuration #8 for DS51:

S	1	2	3	4	5	6	7
M	1	1	1	2	1	2	1
MC	3	5	5	3	5	3	3
NMS	2	7	4	2	7	4	2
OS1	1	15	0	0	5	61	0
OS2	1	16	9	3	5	6	11

Capital cost of the configuration in present value = 6.9807 million US Dollars

Initial investment in the configuration = 28.2100 million US Dollars

System availability of the configuration = 71.816%

System expected production rate of the configuration for part type 1 = 336 parts/hour

System expected production rate of the configuration for part type 2 = 278 parts/hour

System utilization of the configuration = 98.5%

Overall utility function evaluation of the configuration = 6981.01876

9- Configuration #9 for DS51:

S	1	2	3	4	5	6	7
M	1	1	1	2	1	2	1

MC	4	5	5	3	5	3	2
NMS	2	7	4	2	7	4	2
OS1	1	15	0	0	5	61	0
OS2	1	16	9	3	5	6	11

Capital cost of the configuration in present value = 6.9807 million US Dollars

Initial investment in the configuration = 28.2100 million US Dollars

System availability of the configuration = 71.756%

System expected production rate of the configuration for part type 1 = 337 parts/hour

System expected production rate of the configuration for part type 2 = 275 parts/hour

System utilization of the configuration = 99.1%

Overall utility function evaluation of the configuration = 6981.01936

10- Configuration #10 for DS51:

S	1	2	3	4	5	6	7
M	1	1	1	2	1	2	1
MC	2	5	5	3	5	3	2
NMS	3	7	4	2	7	4	2
OS1	1	15	0	0	5	61	0
OS2	1	16	9	3	5	6	11

Capital cost of the configuration in present value = 6.9857 million US Dollars

Initial investment in the configuration = 28.2300 million US Dollars

System availability of the configuration = 71.141%

System expected production rate of the configuration for part type 1 = 340 parts/hour

System expected production rate of the configuration for part type 2 = 279 parts/hour

System utilization of the configuration = 97.9%

Overall utility function evaluation of the configuration = 6985.97463

1.5.2 Demand scenario #2 in CP5 (DS52):

The probability of occurrence of DS52 in CP5 = 30%

The number of part types = 2

1- Part type 1 is to be produced with a rate of 150 parts/hour.

2- Part type 2 is to be produced with a rate of 120 parts/hour.

The first stage of the approach produced 10 near-optimal candidate configurations for DS52 in a duration of 1.3 hours. The configurations are as follows:

1- Configuration #1 for DS52:

S	1	2	3	4	5	6
M	1	1	1	1	1	2
MC	2	5	5	3	5	3
NMS	3	6	6	2	4	4
OS1	1	15	5	0	0	61
OS2	1	16	5	12	9	6

Capital cost of the configuration in present value = 6.2656 million US Dollars

Initial investment in the configuration = 25.3200 million US Dollars

System availability of the configuration = 53.037%





System expected production rate of the configuration for part type 1 = 296 parts/hour  
 System expected production rate of the configuration for part type 2 = 246 parts/hour  
 System utilization of the configuration = 99.5%  
 Overall utility function evaluation of the configuration = 6266.05839

2- Configuration #2 for DS52:

S	1	2	3	4	5	6
M	1	1	1	1	1	2
MC	1	5	5	3	5	3
NMS	4	6	6	2	4	4
OS1	1	15	5	0	0	61
OS2	1	16	5	12	9	6

Capital cost of the configuration in present value = 6.2705 million US Dollars  
 Initial investment in the configuration = 25.3400 million US Dollars  
 System availability of the configuration = 52.687%  
 System expected production rate of the configuration for part type 1 = 296 parts/hour  
 System expected production rate of the configuration for part type 2 = 246 parts/hour  
 System utilization of the configuration = 99.6%  
 Overall utility function evaluation of the configuration = 6271.01101

3- Configuration #3 for DS52:

S	1	2	3	4	5	6
M	1	1	1	1	1	2
MC	2	5	5	3	5	3
NMS	2	5	5	3	6	4
OS1	0	1	0	15	5	61
OS2	1	16	5	12	9	6

Capital cost of the configuration in present value = 6.3349 million US Dollars  
 Initial investment in the configuration = 25.6000 million US Dollars  
 System availability of the configuration = 67.328%  
 System expected production rate of the configuration for part type 1 = 313 parts/hour  
 System expected production rate of the configuration for part type 2 = 235 parts/hour  
 System utilization of the configuration = 99.1%  
 Overall utility function evaluation of the configuration = 6335.20319

4- Configuration #4 for DS52:

S	1	2	3	4	5	6
M	1	1	1	1	1	2
MC	2	5	5	3	5	2
NMS	3	6	6	2	4	6
OS1	1	15	5	0	0	61
OS2	1	16	5	12	9	6

Capital cost of the configuration in present value = 6.3720 million US Dollars  
 Initial investment in the configuration = 25.7500 million US Dollars  
 System availability of the configuration = 55.488%

System expected production rate of the configuration for part type 1 = 299 parts/hour  
 System expected production rate of the configuration for part type 2 = 250 parts/hour  
 System utilization of the configuration = 98.2%  
 Overall utility function evaluation of the configuration = 6372.44001

5- Configuration #5 for DS52:

S	1	2	3	4	5	6
M	1	1	1	1	1	2
MC	2	5	5	4	5	3
NMS	3	6	6	2	4	4
OS1	1	15	5	0	0	61
OS2	1	16	5	12	9	6

Capital cost of the configuration in present value = 6.4042 million US Dollars  
 Initial investment in the configuration = 25.8800 million US Dollars  
 System availability of the configuration = 67.146%  
 System expected production rate of the configuration for part type 1 = 296 parts/hour  
 System expected production rate of the configuration for part type 2 = 254 parts/hour  
 System utilization of the configuration = 97.8%  
 Overall utility function evaluation of the configuration = 6404.49272

6- Configuration #6 for DS52:

S	1	2	3	4	5	6
M	1	1	1	1	1	2
MC	1	5	5	3	5	3
NMS	3	5	5	3	6	4
OS1	0	1	0	15	5	61
OS2	1	16	5	12	9	6

Capital cost of the configuration in present value = 6.4091 million US Dollars  
 Initial investment in the configuration = 25.9000 million US Dollars  
 System availability of the configuration = 66.772%  
 System expected production rate of the configuration for part type 1 = 313 parts/hour  
 System expected production rate of the configuration for part type 2 = 235 parts/hour  
 System utilization of the configuration = 99.1%  
 Overall utility function evaluation of the configuration = 6409.44559

7- Configuration #7 for DS52:

S	1	2	3	4	5	6
M	1	1	1	1	1	2
MC	2	5	5	2	5	3
NMS	3	6	6	3	4	4
OS1	1	15	5	0	0	61
OS2	1	16	5	12	9	6

Capital cost of the configuration in present value = 6.4091 million US Dollars  
 Initial investment in the configuration = 25.9000 million US Dollars  
 System availability of the configuration = 66.571%



System expected production rate of the configuration for part type 1 = 296 parts/hour  
 System expected production rate of the configuration for part type 2 = 255 parts/hour  
 System utilization of the configuration = 97.7%  
 Overall utility function evaluation of the configuration = 6409.44760

8- Configuration #8 for DS52:

S	1	2	3	4	5	6
M	1	1	1	1	1	2
MC	2	5	5	2	5	3
NMS	2	5	5	4	6	4
OS1	0	1	0	15	5	61
OS2	1	16	5	12	9	6

Capital cost of the configuration in present value = 6.4091 million US Dollars  
 Initial investment in the configuration = 25.9000 million US Dollars  
 System availability of the configuration = 66.447%  
 System expected production rate of the configuration for part type 1 = 314 parts/hour  
 System expected production rate of the configuration for part type 2 = 237 parts/hour  
 System utilization of the configuration = 98.5%  
 Overall utility function evaluation of the configuration = 6409.44883

9- Configuration #9 for DS52:

S	1	2	3	4	5	6
M	1	1	1	1	1	2
MC	5	5	5	3	5	3
NMS	4	6	6	2	4	4
OS1	1	15	5	0	0	61
OS2	1	16	5	12	9	6

Capital cost of the configuration in present value = 6.4190 million US Dollars  
 Initial investment in the configuration = 25.9400 million US Dollars  
 System availability of the configuration = 51.711%  
 System expected production rate of the configuration for part type 1 = 295 parts/hour  
 System expected production rate of the configuration for part type 2 = 245 parts/hour  
 System utilization of the configuration = 99.9%  
 Overall utility function evaluation of the configuration = 6419.49443

10- Configuration #10 for DS52:

S	1	2	3	4	5	6
M	1	1	1	1	1	2
MC	2	5	5	3	5	4
NMS	3	6	6	2	4	4
OS1	1	15	5	0	0	61
OS2	1	16	5	12	9	6

Capital cost of the configuration in present value = 6.4339 million US Dollars  
 Initial investment in the configuration = 26.0000 million US Dollars  
 System availability of the configuration = 55.612%



System expected production rate of the configuration for part type 1 = 298 parts/hour  
 System expected production rate of the configuration for part type 2 = 253 parts/hour  
 System utilization of the configuration = 97.8%  
 Overall utility function evaluation of the configuration = 6434.30279

1.5.3 Demand scenario #3 in CP5 (DS53):

The probability of occurrence of DS53 in CP5 = 20%  
 The number of part types = 2  
 1- Part type 1 is to be produced with a rate of 120 parts/hour.  
 2- Part type 2 is to be produced with a rate of 150 parts/hour.

The first stage of the approach produced 10 near-optimal candidate configurations for DS53 in a duration of 1.1 hours. The configurations are as follows:

1- Configuration #1 for DS53:

S	1	2	3	4	5	6	7
M	1	1	2	1	1	1	2
MC	2	5	3	5	5	2	2
NMS	2	6	2	7	5	2	6
OS1	0	1	0	15	5	0	61
OS2	1	16	3	5	9	11	6

Capital cost of the configuration in present value = 6.8100 million US Dollars  
 Initial investment in the configuration = 27.5200 million US Dollars  
 System availability of the configuration = 58.066%  
 System expected production rate of the configuration for part type 1 = 269 parts/hour  
 System expected production rate of the configuration for part type 2 = 277 parts/hour  
 System utilization of the configuration = 98.9%  
 Overall utility function evaluation of the configuration = 6810.41155

2- Configuration #2 for DS53:

S	1	2	3	4	5	6	7
M	1	1	2	1	1	1	2
MC	2	5	3	5	5	1	2
NMS	2	6	2	7	5	3	6
OS1	0	1	0	15	5	0	61
OS2	1	16	3	5	9	11	6

Capital cost of the configuration in present value = 6.8842 million US Dollars  
 Initial investment in the configuration = 27.8200 million US Dollars  
 System availability of the configuration = 57.586%  
 System expected production rate of the configuration for part type 1 = 269 parts/hour  
 System expected production rate of the configuration for part type 2 = 277 parts/hour  
 System utilization of the configuration = 98.9%  
 Overall utility function evaluation of the configuration = 6884.65318

3- Configuration #3 for DS53:

S	1	2	3	4	5	6	7
---	---	---	---	---	---	---	---



M	1	1	2	1	1	1	2
MC	1	5	3	5	5	2	2
NMS	3	6	2	7	5	2	6
OS1	0	1	0	15	5	0	61
OS2	1	16	3	5	9	11	6

Capital cost of the configuration in present value = 6.8842 million US Dollars

Initial investment in the configuration = 27.8200 million US Dollars

System availability of the configuration = 55.821%

System expected production rate of the configuration for part type 1 = 269 parts/hour

System expected production rate of the configuration for part type 2 = 275 parts/hour

System utilization of the configuration = 99.2%

Overall utility function evaluation of the configuration = 6884.67083

4- Configuration #4 for DS53:

S	1	2	3	4	5	6	7
M	1	1	2	1	1	1	2
MC	2	5	4	5	5	2	2
NMS	2	6	2	7	5	2	6
OS1	0	1	0	15	5	0	61
OS2	1	16	3	5	9	11	6

Capital cost of the configuration in present value = 6.8941 million US Dollars

Initial investment in the configuration = 27.8600 million US Dollars

System availability of the configuration = 57.808%

System expected production rate of the configuration for part type 1 = 269 parts/hour

System expected production rate of the configuration for part type 2 = 275 parts/hour

System utilization of the configuration = 99.1%

Overall utility function evaluation of the configuration = 6894.54920

5- Configuration #5 for DS53:

S	1	2	3	4	5	6	7
M	1	1	2	1	1	1	2
MC	2	5	1	5	5	2	2
NMS	2	6	5	7	5	2	6
OS1	0	1	0	15	5	0	61
OS2	1	16	3	5	9	11	6

Capital cost of the configuration in present value = 6.9275 million US Dollars

Initial investment in the configuration = 27.9950 million US Dollars

System availability of the configuration = 58.537%

System expected production rate of the configuration for part type 1 = 269 parts/hour

System expected production rate of the configuration for part type 2 = 279 parts/hour

System utilization of the configuration = 98.4%

Overall utility function evaluation of the configuration = 6927.94849

6- Configuration #6 for DS53:

S	1	2	3	4	5	6	7
---	---	---	---	---	---	---	---



M	1	1	2	1	1	1	2
MC	2	5	3	5	5	2	2
NMS	2	6	2	7	5	2	7
OS1	0	1	0	15	5	0	61
OS2	1	16	3	5	9	11	6

Capital cost of the configuration in present value = 6.9473 million US Dollars

Initial investment in the configuration = 28.0750 million US Dollars

System availability of the configuration = 62.048%

System expected production rate of the configuration for part type 1 = 269 parts/hour

System expected production rate of the configuration for part type 2 = 284 parts/hour

System utilization of the configuration = 97.4%

Overall utility function evaluation of the configuration = 6947.70987

7- Configuration #7 for DS53:

S	1	2	3	4	5	6	7
M	1	1	2	1	1	1	2
MC	2	5	3	5	5	2	2
NMS	2	6	3	7	5	2	6
OS1	0	1	0	15	5	0	61
OS2	1	16	3	5	9	11	6

Capital cost of the configuration in present value = 6.9894 million US Dollars

Initial investment in the configuration = 28.2450 million US Dollars

System availability of the configuration = 58.594%

System expected production rate of the configuration for part type 1 = 269 parts/hour

System expected production rate of the configuration for part type 2 = 279 parts/hour

System utilization of the configuration = 98.4%

Overall utility function evaluation of the configuration = 6989.81195

8- Configuration #8 for DS53:

S	1	2	3	4	5	6	7
M	1	1	2	1	1	1	2
MC	2	5	3	5	5	5	2
NMS	2	6	2	7	5	3	6
OS1	0	1	0	15	5	0	61
OS2	1	16	3	5	9	11	6

Capital cost of the configuration in present value = 6.9956 million US Dollars

Initial investment in the configuration = 28.2700 million US Dollars

System availability of the configuration = 57.010%

System expected production rate of the configuration for part type 1 = 269 parts/hour

System expected production rate of the configuration for part type 2 = 275 parts/hour

System utilization of the configuration = 99.3%

Overall utility function evaluation of the configuration = 6996.01419

9- Configuration #9 for DS53:

S	1	2	3	4	5	6	7
---	---	---	---	---	---	---	---

M	1	1	2	1	1	1	2
MC	2	5	3	5	5	1	2
NMS	2	6	2	7	5	3	7
OS1	0	1	0	15	5	0	61
OS2	1	16	3	5	9	11	6

Capital cost of the configuration in present value = 7.0216 million US Dollars

Initial investment in the configuration = 28.3750 million US Dollars

System availability of the configuration = 61.535%

System expected production rate of the configuration for part type 1 = 269 parts/hour

System expected production rate of the configuration for part type 2 = 284 parts/hour

System utilization of the configuration = 97.4%

Overall utility function evaluation of the configuration = 7021.95183

10- Configuration #10 for DS53:

S	1	2	3	4	5	6	7
M	1	1	2	1	1	1	2
MC	2	5	1	5	5	2	2
NMS	2	6	6	7	5	2	6
OS1	0	1	0	15	5	0	61
OS2	1	16	3	5	9	11	6

Capital cost of the configuration in present value = 7.0228 million US Dollars

Initial investment in the configuration = 28.3800 million US Dollars

System availability of the configuration = 58.642%

System expected production rate of the configuration for part type 1 = 269 parts/hour

System expected production rate of the configuration for part type 2 = 279 parts/hour

System utilization of the configuration = 98.4%

Overall utility function evaluation of the configuration = 7023.21804

1.5.4 Demand scenario #4 in CP5 (DS54):

The probability of occurrence of DS54 in CP5 = 10%

The number of part types = 1

1- Part type 1 is to be produced with a rate of 250 parts/hour.

The first stage of the approach produced 9 near-optimal candidate configurations for DS54 in a duration of 22.4 minutes. The configurations are as follows:

1- Configuration #1 for DS54:

S	1	2	3	4
M	1	1	1	2
MC	2	3	5	3
NMS	2	2	6	3
OS1	1	15	5	61

Capital cost of the configuration in present value = 3.3048 million US Dollars

Initial investment in the configuration = 13.3550 million US Dollars

System availability of the configuration = 40.502%



System expected production rate of the configuration for part type 1 = 257 parts/hour  
System utilization of the configuration = 97.4%  
Overall utility function evaluation of the configuration = 3305.37135

2- Configuration #2 for DS54:

S	1	2	3	4
M	1	1	1	2
MC	3	4	5	4
NMS	1	2	6	3
OS1	1	15	5	61

Capital cost of the configuration in present value = 3.3567 million US Dollars

Initial investment in the configuration = 13.5650 million US Dollars  
System availability of the configuration = 55.357%  
System expected production rate of the configuration for part type 1 = 253 parts/hour  
System utilization of the configuration = 99.0%  
Overall utility function evaluation of the configuration = 3357.18859

3- Configuration #3 for DS54:

S	1	2	3	4
M	1	1	1	2
MC	1	3	5	3
NMS	3	2	6	3
OS1	1	15	5	61

Capital cost of the configuration in present value = 3.3790 million US Dollars

Initial investment in the configuration = 13.6550 million US Dollars  
System availability of the configuration = 38.937%  
System expected production rate of the configuration for part type 1 = 255 parts/hour  
System utilization of the configuration = 97.9%  
Overall utility function evaluation of the configuration = 3379.62384

4- Configuration #4 for DS54:

S	1	2	3	4
M	1	1	1	2
MC	2	3	5	4
NMS	2	2	6	3
OS1	1	15	5	61

Capital cost of the configuration in present value = 3.4310 million US Dollars

Initial investment in the configuration = 13.8650 million US Dollars  
System availability of the configuration = 53.351%  
System expected production rate of the configuration for part type 1 = 265 parts/hour  
System utilization of the configuration = 94.2%  
Overall utility function evaluation of the configuration = 3431.44549

5- Configuration #5 for DS54:

S	1	2	3	4
M	1	1	1	2
MC	3	3	5	3

NMS	1	3	6	3
OS1	1	15	5	61

Capital cost of the configuration in present value = 3.4434 million US Dollars

Initial investment in the configuration = 13.9150 million US Dollars

System availability of the configuration = 54.563%

System expected production rate of the configuration for part type 1 = 257 parts/hour

System utilization of the configuration = 97.1%

Overall utility function evaluation of the configuration = 3443.80617

6- Configuration #6 for DS54:

S	1	2	3	4
M	1	1	1	2
MC	3	3	5	3
NMS	2	2	6	3
OS1	1	15	5	61

Capital cost of the configuration in present value = 3.4434 million US Dollars

Initial investment in the configuration = 13.9150 million US Dollars

System availability of the configuration = 49.283%

System expected production rate of the configuration for part type 1 = 264 parts/hour

System utilization of the configuration = 94.6%

Overall utility function evaluation of the configuration = 3443.85897

7- Configuration #7 for DS54:

S	1	2	3	4
M	1	1	1	2
MC	2	4	5	3
NMS	2	2	6	3
OS1	1	15	5	61

Capital cost of the configuration in present value = 3.4434 million US Dollars

Initial investment in the configuration = 13.9150 million US Dollars

System availability of the configuration = 38.682%

System expected production rate of the configuration for part type 1 = 266 parts/hour

System utilization of the configuration = 94.1%

Overall utility function evaluation of the configuration = 3443.96498

8- Configuration #8 for DS54:

S	1	2	3	4
M	1	1	1	2
MC	2	2	5	3
NMS	2	3	6	3
OS1	1	15	5	61

Capital cost of the configuration in present value = 3.4483 million US Dollars

Initial investment in the configuration = 13.9350 million US Dollars

System availability of the configuration = 38.128%

System expected production rate of the configuration for part type 1 = 266 parts/hour

System utilization of the configuration = 93.8%  
Overall utility function evaluation of the configuration = 3448.91964

9- Configuration #9 for DS54:

S	1	2	3	4
M	1	1	1	2
MC	2	3	5	2
NMS	2	2	6	5
OS1	1	15	5	61

Capital cost of the configuration in present value = 3.4533 million US Dollars

Initial investment in the configuration = 13.9550 million US Dollars

System availability of the configuration = 52.539%

System expected production rate of the configuration for part type 1 = 267 parts/hour

System utilization of the configuration = 93.6%

Overall utility function evaluation of the configuration = 3453.72466

## 2. The Second Stage Using GAs:

This stage of the approach targeted optimizing the RS evaluation across all configuration periods by selecting near-optimal sets of configurations corresponding to the different demand scenarios in the different configuration periods from those produced in the first stage.

The degree of relevance of the demand scenarios provided for each CP is reflected in the results of the second stage by the following relative importance factors assigned to each CP:

The relative importance of CP1 = 45%

The relative importance of CP2 = 25%

The relative importance of CP3 = 15%

The relative importance of CP4 = 10%

The relative importance of CP5 = 5%

The optimization method used in the second stage is "Genetic Algorithms" with the following parameters:

Population size = 140

Number of generations = 120

Number of times to apply uniform mutation = 8

Number of times to apply boundary mutation = 8

Number of times to apply non-uniform mutation = 8

Number of times to apply whole arithmetic cross-over = 4

Number of times to apply simple arithmetic cross-over = 4

Number of times to apply whole non-uniform mutation = 8

Number of times to apply heuristic cross-over = 4

Parameter for non uniform mutation = 6

Parameter for simple cross-over = 10

Q = 0.1

The maximum number of configuration sets generated is 10.

The maximum tolerance limit for the configuration sets compared to their best set is 5%.

The reconfiguration smoothness limit (RSL) was found to be 0.23478.

The second stage of the approach produced 10 near-optimal sets of configurations:

2.1 Near-optimal set of configurations #1:

- Configuration #3 for CP1
- Configuration #8 for DS21 in CP2
- Configuration #6 for DS22 in CP2
- Configuration #3 for DS31 in CP3
- Configuration #7 for DS32 in CP3
- Configuration #8 for DS33 in CP3
- Configuration #4 for DS41 in CP4
- Configuration #2 for DS42 in CP4
- Configuration #5 for DS51 in CP5
- Configuration #7 for DS52 in CP5
- Configuration #7 for DS53 in CP5
- Configuration #8 for DS54 in CP5

The RS evaluation of this set across all configuration periods = 0.22335

Therefore, according to this set of configurations, the selected configuration for CP1 (the period of interest) is Configuration #3. This configuration, as previously reported in the outcome results of the first stage, has the following objective function evaluations:

Capital cost of the configuration in present value = 7.7802 million US Dollars

Initial investment in the configuration = 27.8200 million US Dollars

Reconfiguration smoothness (RS) value of the configuration from C0 = 0.29392

System availability of the configuration = 73.526%

System expected production rate of the configuration for part type 1 = 343 parts/hour

System expected production rate of the configuration for part type 2 = 284 parts/hour

System utilization of the configuration = 98.3%

Overall utility function evaluation of the configuration = 7780.44292

The RS value mentioned above (0.29392) is a result of an action plan of reconfiguration that was developed according to a set of reconfiguration planning rules. In order to present this action plan, both C0 and the selected configuration for CP1 (Configuration #3), which will be referred to as C1, are re-demonstrated as follows:

The original configuration (C0) was as follows:

S(SL)	1(3)	2(4)	3(5)	4(6)	5(7)	6(8)
M	1	1	1	2	2	1
MC	5	3	5	3	1	2
NMS	4	6	5	2	6	2
OS1	1	14	5	61	3	0
OS2	9	5	13	6	3	11

The selected configuration for CP1 (C1) is as follows:

S(SL)	1(1)	2(2)	3(3)	4(4)	5(5)	6(6)	7(7)
M	1	1	1	1	1	1	2
MC	2	3	2	5	2	5	2
NMS	3	3	3	7	2	4	6
OS1	1	0	14	5	0	3	61
OS2	1	15	13	5	11	9	6



Reconfiguration Action Plan from C0 into C1:

I) Stages:

- 1- Stage of type M1 located in SL3 will keep its location in the system.
- 2- Stage of type M1 located in SL4 will keep its location in the system.
- 3- Stage of type M1 located in SL5 will keep its location in the system.
- 4- Stage of type M2 located in SL7 will keep its location in the system.
- 5- Stage of type M2 located in SL6 will be totally removed from the system.
- 6- Stage of type M1 located in SL8 will be relocated to SL1 of the system.
- 7- A new stage of type M1 will be added to SL2 of the system.
- 8- A new stage of type M1 will be added to SL6 of the system.

II) Machines:

- 1- 3 M1 machines located in SL3 will keep their location in the system.
- 2- 6 M1 machines located in SL4 will keep their location in the system.
- 3- 2 M1 machines located in SL5 will keep their location in the system.
- 4- 6 M2 machines located in SL7 will keep their location in the system.
- 5- 2 M2 machines located in SL6 will be totally removed from the system.
- 6- 1 M1 machine located in SL3 will be relocated to SL2 of the system.
- 7- 2 M1 machines located in SL5 will be relocated to SL2 of the system.
- 8- 1 M1 machine located in SL5 will be relocated to SL6 of the system.
- 9- 2 M1 machines located in SL8 will be relocated to SL1 of the system.
- 10- 1 new M1 machine will be added to SL1 of the system.
- 11- 1 new M1 machine will be added to SL4 of the system.
- 12- 3 new M1 machines will be added to SL6 of the system.

2.2 Near-optimal set of configurations #2:

Configuration #3 for CP1  
Configuration #8 for DS21 in CP2  
Configuration #6 for DS22 in CP2  
Configuration #3 for DS31 in CP3  
Configuration #7 for DS32 in CP3  
Configuration #8 for DS33 in CP3  
Configuration #4 for DS41 in CP4  
Configuration #2 for DS42 in CP4  
Configuration #1 for DS51 in CP5  
Configuration #7 for DS52 in CP5  
Configuration #7 for DS53 in CP5  
Configuration #8 for DS54 in CP5

The RS evaluation of this set across all configuration periods = 0.22335

Therefore, according to this set of configurations, the selected configuration for CP1 (the period of interest) is Configuration #3.

#### 2.3 Near-optimal set of configurations #3:

Configuration #3 for CP1  
Configuration #8 for DS21 in CP2  
Configuration #6 for DS22 in CP2  
Configuration #3 for DS31 in CP3  
Configuration #7 for DS32 in CP3  
Configuration #8 for DS33 in CP3  
Configuration #4 for DS41 in CP4  
Configuration #2 for DS42 in CP4  
Configuration #5 for DS51 in CP5  
Configuration #7 for DS52 in CP5  
Configuration #7 for DS53 in CP5  
Configuration #9 for DS54 in CP5

The RS evaluation of this set across all configuration periods = 0.22336

Therefore, according to this set of configurations, the selected configuration for CP1 (the period of interest) is Configuration #3.

#### 2.4 Near-optimal set of configurations #4:

Configuration #3 for CP1  
Configuration #8 for DS21 in CP2  
Configuration #6 for DS22 in CP2  
Configuration #3 for DS31 in CP3  
Configuration #7 for DS32 in CP3  
Configuration #8 for DS33 in CP3  
Configuration #4 for DS41 in CP4  
Configuration #2 for DS42 in CP4  
Configuration #1 for DS51 in CP5  
Configuration #7 for DS52 in CP5  
Configuration #7 for DS53 in CP5  
Configuration #9 for DS54 in CP5

The RS evaluation of this set across all configuration periods = 0.22336

Therefore, according to this set of configurations, the selected configuration for CP1 (the period of interest) is Configuration #3.

#### 2.5 Near-optimal set of configurations #5:

Configuration #3 for CP1  
Configuration #8 for DS21 in CP2  
Configuration #6 for DS22 in CP2  
Configuration #3 for DS31 in CP3  
Configuration #7 for DS32 in CP3  
Configuration #8 for DS33 in CP3  
Configuration #4 for DS41 in CP4  
Configuration #2 for DS42 in CP4  
Configuration #5 for DS51 in CP5  
Configuration #7 for DS52 in CP5  
Configuration #1 for DS53 in CP5  
Configuration #8 for DS54 in CP5

The RS evaluation of this set across all configuration periods = 0.22336

Therefore, according to this set of configurations, the selected configuration for CP1 (the period of interest) is Configuration #3.

2.6 Near-optimal set of configurations #6:

Configuration #3 for CP1  
Configuration #8 for DS21 in CP2  
Configuration #6 for DS22 in CP2  
Configuration #3 for DS31 in CP3  
Configuration #7 for DS32 in CP3  
Configuration #8 for DS33 in CP3  
Configuration #4 for DS41 in CP4  
Configuration #10 for DS42 in CP4  
Configuration #5 for DS51 in CP5  
Configuration #7 for DS52 in CP5  
Configuration #7 for DS53 in CP5  
Configuration #9 for DS54 in CP5

The RS evaluation of this set across all configuration periods = 0.22336

Therefore, according to this set of configurations, the selected configuration for CP1 (the period of interest) is Configuration #3.

2.7 Near-optimal set of configurations #7:

Configuration #3 for CP1  
Configuration #8 for DS21 in CP2  
Configuration #6 for DS22 in CP2  
Configuration #3 for DS31 in CP3  
Configuration #7 for DS32 in CP3  
Configuration #8 for DS33 in CP3  
Configuration #4 for DS41 in CP4  
Configuration #10 for DS42 in CP4  
Configuration #1 for DS51 in CP5  
Configuration #7 for DS52 in CP5  
Configuration #7 for DS53 in CP5  
Configuration #9 for DS54 in CP5

The RS evaluation of this set across all configuration periods = 0.22336

Therefore, according to this set of configurations, the selected configuration for CP1 (the period of interest) is Configuration #3.

2.8 Near-optimal set of configurations #8:

Configuration #3 for CP1  
Configuration #8 for DS21 in CP2  
Configuration #6 for DS22 in CP2  
Configuration #3 for DS31 in CP3  
Configuration #7 for DS32 in CP3  
Configuration #8 for DS33 in CP3  
Configuration #4 for DS41 in CP4  
Configuration #10 for DS42 in CP4  
Configuration #5 for DS51 in CP5  
Configuration #7 for DS52 in CP5  
Configuration #7 for DS53 in CP5  
Configuration #8 for DS54 in CP5

The RS evaluation of this set across all configuration periods = 0.22336



Therefore, according to this set of configurations, the selected configuration for CP1 (the period of interest) is Configuration #3.

#### 2.9 Near-optimal set of configurations #9:

Configuration #3 for CP1  
Configuration #8 for DS21 in CP2  
Configuration #6 for DS22 in CP2  
Configuration #3 for DS31 in CP3  
Configuration #7 for DS32 in CP3  
Configuration #8 for DS33 in CP3  
Configuration #4 for DS41 in CP4  
Configuration #10 for DS42 in CP4  
Configuration #1 for DS51 in CP5  
Configuration #7 for DS52 in CP5  
Configuration #7 for DS53 in CP5  
Configuration #8 for DS54 in CP5

The RS evaluation of this set across all configuration periods = 0.22336

Therefore, according to this set of configurations, the selected configuration for CP1 (the period of interest) is Configuration #3.

#### 2.10 Near-optimal set of configurations #10:

Configuration #3 for CP1  
Configuration #8 for DS21 in CP2  
Configuration #6 for DS22 in CP2  
Configuration #3 for DS31 in CP3  
Configuration #7 for DS32 in CP3  
Configuration #8 for DS33 in CP3  
Configuration #4 for DS41 in CP4  
Configuration #2 for DS42 in CP4  
Configuration #5 for DS51 in CP5  
Configuration #7 for DS52 in CP5  
Configuration #1 for DS53 in CP5  
Configuration #9 for DS54 in CP5

The RS evaluation of this set across all configuration periods = 0.22336

Therefore, according to this set of configurations, the selected configuration for CP1 (the period of interest) is Configuration #3.

### 3. The Second Stage Using RTS:

This stage of the approach targeted optimizing the RS evaluation across all configuration periods by selecting near-optimal sets of configurations corresponding to the different demand scenarios in the different configuration periods from those produced in the first stage.

The degree of relevance in the demand scenarios provided for each CP is reflected in the results of the second stage by the following relative importance factors assigned to each CP:

The relative importance of CP1 = 45%  
The relative importance of CP2 = 25%  
The relative importance of CP3 = 15%  
The relative importance of CP4 = 10%  
The relative importance of CP5 = 5%

The optimization method used in the second stage is "Reactive Tabu Search" with the following parameters:  
Starting point (0 for random & 1 for average value of each variable range) = 0  
Maximum number of objective function evaluations = 20000  
Maximum number of iterations = 100  
Maximum number of iterations with same best objective function value = 50  
Maximum number of box encounters after which the box is considered one of the often repeated configurations = 3  
Maximum number of often repeated configurations after which the escape mechanism is performed = 3  
Percentage by which the prohibition period is increased in diversification = 1.1  
Percentage by which the prohibition period is decreased in intensification = 0.9

The maximum number of configuration sets generated is 10.

The maximum tolerance limit for the configuration sets compared to their best set is 5%.

The reconfiguration smoothness limit (RSL) was found to be 0.23478.

The second stage of the approach produced 10 near-optimal sets of configurations:

#### 2.1 Near-optimal set of configurations #1:

Configuration #3 for CP1  
Configuration #8 for DS21 in CP2  
Configuration #6 for DS22 in CP2  
Configuration #3 for DS31 in CP3  
Configuration #7 for DS32 in CP3  
Configuration #8 for DS33 in CP3  
Configuration #4 for DS41 in CP4  
Configuration #2 for DS42 in CP4  
Configuration #5 for DS51 in CP5  
Configuration #7 for DS52 in CP5  
Configuration #7 for DS53 in CP5  
Configuration #8 for DS54 in CP5

The RS evaluation of this set across all configuration periods = 0.22335

Therefore, according to this set of configurations, the selected configuration for CP1 (the period of interest) is Configuration #3. This configuration, as previously reported in the outcome results of the first stage, has the following objective function evaluations:

Capital cost of the configuration in present value = 7.7802 million US Dollars

Initial investment in the configuration = 27.8200 million US Dollars

Reconfiguration smoothness (RS) value of the configuration from C0 = 0.29392

System availability of the configuration = 73.526%

System expected production rate of the configuration for part type 1 = 343 parts/hour

System expected production rate of the configuration for part type 2 = 284 parts/hour

System utilization of the configuration = 98.3%  
 Overall utility function evaluation of the configuration = 7780.44292

The RS value mentioned above (0.29392) is a result of an action plan of reconfiguration that was developed according to a set of reconfiguration planning rules. In order to present this action plan, both C0 and the selected configuration for CP1 (Configuration #3), which will be referred to as C1, are re-demonstrated as follows:

The original configuration (C0) was as follows:

S(SL)	1(3)	2(4)	3(5)	4(6)	5(7)	6(8)
M	1	1	1	2	2	1
MC	5	3	5	3	1	2
NMS	4	6	5	2	6	2
OS1	1	14	5	61	3	0
OS2	9	5	13	6	3	11

The selected configuration for CP1 (C1) is as follows:

S(SL)	1(1)	2(2)	3(3)	4(4)	5(5)	6(6)	7(7)
M	1	1	1	1	1	1	2
MC	2	3	2	5	2	5	2
NMS	3	3	3	7	2	4	6
OS1	1	0	14	5	0	3	61
OS2	1	15	13	5	11	9	6

Reconfiguration Action Plan from C0 into C1:

I) Stages:

- 1- Stage of type M1 located in SL3 will keep its location in the system.
- 2- Stage of type M1 located in SL4 will keep its location in the system.
- 3- Stage of type M1 located in SL5 will keep its location in the system.
- 4- Stage of type M2 located in SL7 will keep its location in the system.
- 5- Stage of type M2 located in SL6 will be totally removed from the system.
- 6- Stage of type M1 located in SL8 will be relocated to SL1 of the system.
- 7- A new stage of type M1 will be added to SL2 of the system.
- 8- A new stage of type M1 will be added to SL6 of the system.

II) Machines:

- 1- 3 M1 machines located in SL3 will keep their location in the system.
- 2- 6 M1 machines located in SL4 will keep their location in the system.
- 3- 2 M1 machines located in SL5 will keep their location in the system.
- 4- 6 M2 machines located in SL7 will keep their location in the system.
- 5- 2 M2 machines located in SL6 will be totally removed from the system.
- 6- 1 M1 machine located in SL3 will be relocated to SL2 of the system.
- 7- 2 M1 machines located in SL5 will be relocated to SL2 of the system.

- 8- 1 M1 machine located in SL5 will be relocated to SL6 of the system.
- 9- 2 M1 machines located in SL8 will be relocated to SL1 of the system.
- 10- 1 new M1 machine will be added to SL1 of the system.
- 11- 1 new M1 machine will be added to SL4 of the system.
- 12- 3 new M1 machines will be added to SL6 of the system.

2.2 Near-optimal set of configurations #2:

- Configuration #3 for CP1
- Configuration #8 for DS21 in CP2
- Configuration #6 for DS22 in CP2
- Configuration #3 for DS31 in CP3
- Configuration #7 for DS32 in CP3
- Configuration #8 for DS33 in CP3
- Configuration #4 for DS41 in CP4
- Configuration #2 for DS42 in CP4
- Configuration #1 for DS51 in CP5
- Configuration #7 for DS52 in CP5
- Configuration #7 for DS53 in CP5
- Configuration #8 for DS54 in CP5

The RS evaluation of this set across all configuration periods = 0.22335

Therefore, according to this set of configurations, the selected configuration for CP1 (the period of interest) is Configuration #3.

2.3 Near-optimal set of configurations #3:

- Configuration #3 for CP1
- Configuration #8 for DS21 in CP2
- Configuration #6 for DS22 in CP2
- Configuration #3 for DS31 in CP3
- Configuration #7 for DS32 in CP3
- Configuration #8 for DS33 in CP3
- Configuration #4 for DS41 in CP4
- Configuration #2 for DS42 in CP4
- Configuration #5 for DS51 in CP5
- Configuration #7 for DS52 in CP5
- Configuration #7 for DS53 in CP5
- Configuration #9 for DS54 in CP5

The RS evaluation of this set across all configuration periods = 0.22336

Therefore, according to this set of configurations, the selected configuration for CP1 (the period of interest) is Configuration #3.

2.4 Near-optimal set of configurations #4:

- Configuration #3 for CP1
- Configuration #8 for DS21 in CP2
- Configuration #6 for DS22 in CP2
- Configuration #3 for DS31 in CP3
- Configuration #7 for DS32 in CP3
- Configuration #8 for DS33 in CP3
- Configuration #4 for DS41 in CP4
- Configuration #2 for DS42 in CP4
- Configuration #1 for DS51 in CP5
- Configuration #7 for DS52 in CP5



Configuration #7 for DS53 in CP5  
Configuration #9 for DS54 in CP5

The RS evaluation of this set across all configuration periods = 0.22336

Therefore, according to this set of configurations, the selected configuration for CP1 (the period of interest) is Configuration #3.

#### 2.5 Near-optimal set of configurations #5:

Configuration #3 for CP1  
Configuration #8 for DS21 in CP2  
Configuration #6 for DS22 in CP2  
Configuration #3 for DS31 in CP3  
Configuration #7 for DS32 in CP3  
Configuration #8 for DS33 in CP3  
Configuration #4 for DS41 in CP4  
Configuration #2 for DS42 in CP4  
Configuration #5 for DS51 in CP5  
Configuration #7 for DS52 in CP5  
Configuration #1 for DS53 in CP5  
Configuration #8 for DS54 in CP5

The RS evaluation of this set across all configuration periods = 0.22336

Therefore, according to this set of configurations, the selected configuration for CP1 (the period of interest) is Configuration #3.

#### 2.6 Near-optimal set of configurations #6:

Configuration #3 for CP1  
Configuration #8 for DS21 in CP2  
Configuration #6 for DS22 in CP2  
Configuration #3 for DS31 in CP3  
Configuration #7 for DS32 in CP3  
Configuration #8 for DS33 in CP3  
Configuration #4 for DS41 in CP4  
Configuration #2 for DS42 in CP4  
Configuration #1 for DS51 in CP5  
Configuration #7 for DS52 in CP5  
Configuration #1 for DS53 in CP5  
Configuration #8 for DS54 in CP5

The RS evaluation of this set across all configuration periods = 0.22336

Therefore, according to this set of configurations, the selected configuration for CP1 (the period of interest) is Configuration #3.

#### 2.7 Near-optimal set of configurations #7:

Configuration #3 for CP1  
Configuration #8 for DS21 in CP2  
Configuration #6 for DS22 in CP2  
Configuration #3 for DS31 in CP3  
Configuration #7 for DS32 in CP3  
Configuration #8 for DS33 in CP3  
Configuration #4 for DS41 in CP4  
Configuration #10 for DS42 in CP4  
Configuration #5 for DS51 in CP5  
Configuration #7 for DS52 in CP5

Configuration #7 for DS53 in CP5  
Configuration #9 for DS54 in CP5

The RS evaluation of this set across all configuration periods = 0.22336

Therefore, according to this set of configurations, the selected configuration for CP1 (the period of interest) is Configuration #3.

#### 2.8 Near-optimal set of configurations #8:

Configuration #3 for CP1  
Configuration #8 for DS21 in CP2  
Configuration #6 for DS22 in CP2  
Configuration #3 for DS31 in CP3  
Configuration #7 for DS32 in CP3  
Configuration #8 for DS33 in CP3  
Configuration #4 for DS41 in CP4  
Configuration #10 for DS42 in CP4  
Configuration #1 for DS51 in CP5  
Configuration #7 for DS52 in CP5  
Configuration #7 for DS53 in CP5  
Configuration #9 for DS54 in CP5

The RS evaluation of this set across all configuration periods = 0.22336

Therefore, according to this set of configurations, the selected configuration for CP1 (the period of interest) is Configuration #3.

#### 2.9 Near-optimal set of configurations #9:

Configuration #3 for CP1  
Configuration #8 for DS21 in CP2  
Configuration #6 for DS22 in CP2  
Configuration #3 for DS31 in CP3  
Configuration #7 for DS32 in CP3  
Configuration #8 for DS33 in CP3  
Configuration #4 for DS41 in CP4  
Configuration #10 for DS42 in CP4  
Configuration #5 for DS51 in CP5  
Configuration #7 for DS52 in CP5  
Configuration #7 for DS53 in CP5  
Configuration #8 for DS54 in CP5

The RS evaluation of this set across all configuration periods = 0.22336

Therefore, according to this set of configurations, the selected configuration for CP1 (the period of interest) is Configuration #3.

#### 2.10 Near-optimal set of configurations #10:

Configuration #3 for CP1  
Configuration #8 for DS21 in CP2  
Configuration #6 for DS22 in CP2  
Configuration #3 for DS31 in CP3  
Configuration #7 for DS32 in CP3  
Configuration #8 for DS33 in CP3  
Configuration #4 for DS41 in CP4  
Configuration #10 for DS42 in CP4  
Configuration #1 for DS51 in CP5  
Configuration #7 for DS52 in CP5

Configuration #7 for DS53 in CP5  
Configuration #8 for DS54 in CP5

The RS evaluation of this set across all configuration periods = 0.22336

Therefore, according to this set of configurations, the selected configuration for CP1 (the period of interest) is Configuration #3.

Runtime elapsed in stage 1 = 12.0 hours  
Average elapsed runtime for each DS in stage 1 = 59.8 minutes  
Runtime elapsed in stage 2 using GAs = 7.1 hours  
Runtime elapsed in stage 2 using RTS = 4.8 hours  
Total elapsed runtime using GAs in stage 2 = 19.1 hours  
Total elapsed runtime using RTS in stage 2 = 16.8 hours



## VITA AUCTORIS

NAME: Ayman Mohamed Ashraf Mohamed Youssef

PLACE OF BIRTH Cairo, Egypt

YEAR OF BIRTH 1975

EDUCATION Dar-El-Tarbiah Language School, Cairo, Egypt  
1989-1993

Cairo University, Cairo, Egypt  
1993-1998 B.Sc.

Cairo University, Cairo, Egypt  
1998-2001 M.Sc.

University of Windsor, Windsor, Ontario, Canada  
2001-2006 Ph.D.